

BIPT

Ter attentie van de **sector van de elektronische communicatie**

Dossierbeheerder Axel Palmaers (Fr)
Ingenieur-Adviseur
Pool Telecom & Media
axel.palmaers@ibpt.be

Onze Ref.
12/APA/BRxx 2012/Précons

tél. +32 2 226 88 46
fax +32 2 226 88 41

Brussel, 22 februari 2012

Betreft : Voorafgaandelijke raadpleging betreffende het voorstel tot wijziging van de referentieaanbiedingen van Belgacom van 17 februari 2012

Op 17 februari 2012 heeft het BIPT van Belgacom **aanzienlijke wijzigingen aan de referentieaanbiedingen BRxx en WBA** ontvangen, waarmee Belgacom ingaat op de verplichtingen voortkomende uit de beslissing van de CRC van 1 juli 2011 betreffende de analyse van de breedbandmarkten en de beslissing van de Raad van het BIPT van 11 augustus 2011 betreffende de referentieaanbiedingen BRUO/BROBA/WBA VDSL2/BROTSoLL 2010. Belgacom heeft eveneens van de gelegenheid gebruik gemaakt om op vrijwillige basis nieuwe wijzigingen voor te stellen. Een lijst met al deze wijzigingen alsook een copie van de gewijzigde referentieaanbiedingen zijn als bijlage bij deze brief gevoegd.

Met deze brief, **nodigen wij u uit om te reageren op het voorstel** van Belgacom aangaande de wijziging van de referentieaanbiedingen **op volgende wijze** :

- via e-mail op het volgende adres : axel.palmaers@ibpt.be
- tot vrijdag **16 maart 2012 ten laatste 12u**
- omwille van technische redenen zijn de voorgestelde wijzigingen aan het BRUO, BROBA et WBA VDSL2 referentieaanbod afzonderlijk gepubliceerd op de website van het BIPT. Wij vragen u echter om uw reacties op de voorstellen te consolideren in één enkel document
- wij vragen u om in dit stadium nog geen opmerkingen te voorzien aangaande de bijzonderheden van de operationele processen zoals deze verduidelijkt worden via de *process flows* die voorzien worden in de bijlagen van de referentieaanbiedingen.

Axel Palmaers (+32 2 226 88 46) zal met plezier antwoorden op eventuele vragen die u hierover zou hebben.

Bijlage(s) :
1. Lijst met aanpassingen aan de referentieaanbiedingen
2. Lijst met documenten betreffende de referentieaanbiedingen in bijlage
3. Referentieaanbiedingen BRUO, BROBA et WBA VDSL2 aangepast op 17 februari 2012

Pagina 1 van 7

BIJLAGE 1 – LIJST MET AANPASSINGEN AAN DE REFERENTIEAANBIEDINGEN

Voornaamste wijzigingen

1. Het invoegen van een duidelijk **onderscheid** tussen de « **Ordering** » en de « **Provisioning** » processen.
2. **Gedetailleerde omschrijving van de operationele processen** op basis van « process flows » zoals voorgesteld in OWG/1106
3. De invoeging van een nieuwe **procedure voor verandering van de Tie cable** in het geval er een defect op een DSLAM poort van de OLO aanwezig is (enkel **BRUO**)
4. De invoeging van een **nieuwe procedure om met de meetresultaten van de alternatieve operatoren rekening te houden** in het geval van een vraag tot herstel en het opzetten van een gestandiseerde template (BRUO)
5. **De herintroductie van notificatietermijnen betreffende IT wijzigingen** gezien dit per ongeluk afgeschaft is geweest tijdens de vorige herziening van de referentieaanbiedingen
6. De invoeging van een **Backhaul GE aanbod** in de BROBA en WBA aanbiedingen
7. De invoeging van een **vergoeding** van het type « **pending order due to useless end-user visit** »
8. De invoeging van een **clausule** waardoor Belgacom een **niet redelijke vraag tot toegang** kan weigeren
9. Verbetering van de coherentie tussen een **Basic SLA en een Improved SLA voor wat betreft repair** in overeenstemming met de inhoud van de « ISLA Repair Information Session » zoals voorgesteld door Belgacom tijdens OWG/1105
10. **Verduidelijking van de aanbiedingen betreffende de berekening van de SLA's**, de geïndividualiseerde KPI verslagen en de mogelijke **compensaties** die daaruit kunnen voortvloeien
11. Verfijning van de SLA's aangaande de IT tools

Kleinere aanpassingen

12. Uniformisering van de termen « end-user » en « user » tussen de verschillende aanbiedingen

13. De beperking « if no further delay because of public domain obligations » zoals vermeld in het BRUO aanbod wordt uitgebreid naar de BROBA et WBA referentieaanbiedingen
14. De termijnen verbonden aan een aanvraag met betrekking Dedicated VLAN profielen in het BROBA aanbod zijn vanaf nu ook opgenomen in het WBA aanbod
15. De invoeging van een beschrijving van de bijlagen bij de referentieaanboden onder de titel « General Information » in de bijlage GT&C
16. De bijlagen bij het WBA aanbod zijn hernummerd
17. De bijlagen Pricing and Billing bevatten vanaf nu een samenvattende tabel met de prijzen
18. De verwijzingen naar de escalatieprocedures zijn verbeterd
19. ...

Compléments d'information

Voor wat betreft de afzonderlijke facturering van de activeringskosten, de desactiveringskosten en de kosten aangaande de configuratie zoals gevraagd door Belgacom in het kader van het BROBA Ethernet aanbod goedgekeurd door de beslissing van de Raad van het BIPT op 11 augustus 2011, heeft Belgacom aangegeven dat ze de oorspronkelijke situatie opnieuw ingevoerd heeft ondanks deze beslissing omwille van materiële redenen.

BIJLAGE 2 - LIJST MET DOCUMENTEN BETREFFENDE DE REFERENTIEAANBIEDINGEN

De documenten betreffende de referentieaanbiedingen die men terug kan vinden in bijlage 3 worden opgedeeld in de volgorde zoals hieronder weergegeven.

Voor technische redenen werden de voorstellen van wijzingen aan de referentieaanbiedingen BRUO, BROBA en WBA VDSL2 in 4 onafhankelijke delen gepubliceerd op de website van het BIPT. De URL's van deze 4 delen worden hieronder meegedeeld.

Deel 1A - BRUO

Deze documenten zijn op het volgende adres beschikbaar :

<http://ibpt.be/ShowDoc.aspx?objectID=3707>

Type	Document	Description
BRUO	Main Body	
BRUO	Annex A	General Terms and Conditions
BRUO	Annex C	Technical specifications
BRUO RC	Annex D1	Billing and Accounting
BRUO SP	Annex D2	Billing and Accounting
BRUO	Annex D3	Billing and Accounting
BRUO	Annex E	Planning and Operations
BRUO	Annex F	OSS
BRUO	Annex G1	Basic SLA
BRUO	Annex G2	ISLA Repair
BRUO	Annex G3	ISLA Provisioning
BRUO	Annex H	Price List

Deel 1B - BRUO

Deze documenten zijn op het volgende adres beschikbaar :

<http://ibpt.be/ShowDoc.aspx?objectID=3708>

Type	Document	Description
BRUO RC	Annex B1.1	SD2010
BRUO RC	Annex B1.2	SD2030
BRUO RC	Annex B1.3	SD2035
BRUO	Annex B1.4 B2.4 Appendix A	
BRUO	Annex B1.4 B2.4 Appendix B	
BRUO RC	Annex B1.4	SD2040
BRUO RC	Annex B1.5	SD2015
BRUO RC	Annex B1.6	SD2045
BRUO RC	Annex B1.7	SD2050
BRUO	Annex B1.8	Multiple pairs ordering
BRUO SP	Annex B2.1	SD3010

BRUO SP	Annex B2.2	SD3030
BRUO SP	Annex B2.3	SD3035
BRUO SP	Annex B2.4	SD3040
BRUO SP	Annex B2.5	SD3015
BRUO SP	Annex B2.6	SD3045
BRUO	Annex Ja	Intro
BRUO	Annex Jb	NDA
BRUO	Annex Jc	Technical Spec Tie Cable
BRUO	Annex Jd	Type 1 Pair Selection
BRUO	Annex Je	Type 2 Pair Selection
BRUO	Annex Jf	Shared Pair Pair Selection
BRUO	Annex Jg	Technical Spec Cables
BRUO	Annex Jh	KVD streets
BRUO	Annex K	Migrations to BRUO/BROBA/WBA

Deel 2 - BROBA

Deze documenten zijn op het volgende adres beschikbaar :

<http://ibpt.be/ShowDoc.aspx?objectID=3709>

Type	Document	Description
BROBA ADSL	Main Body	
BROBA ADSL	Annex 2	Technical Spec
BROBA ADSL	Annex 6	Pricing and Billing
BROBA ADSL-SDSL	Annex 1	General Terms and Conditions
BROBA ADSL-SDSL	Annex 2	Technical Spec
BROBA ADSL-SDSL	Annex 3	Exchange of information
BROBA ADSL-SDSL	Annex 4	Planning and Operations
BROBA ADSL-SDSL	Annex 5	Basic SLA
BROBA ADSL-SDSL	Annex 5A	ISLA Repair
BROBA ADSL-SDSL	Annex 5B	ISLA Provisioning
BROBA ADSL-SDSL	Annex 8	Prepayment Terms Conditions
BROBA SDSL	Main Body	
BROBA SDSL	Annex 2	Technical Spec
BROBA SDSL	Annex 6	Pricing and Billing

Deel 3 - WBA VDSL2

Deze documenten zijn op het volgende adres beschikbaar :

<http://ibpt.be/ShowDoc.aspx?objectID=3710>

Type	Document	Description
WBA VDSL2	Main Body	
WBA VDSL2	Annex 1	General terms and conditions
WBA VDSL2	Annex 2	Technical Spec
WBA VDSL2	Annex 3	Planning and Operations
WBA VDSL2	Annex 4	Basic SLA
WBA VDSL2	Annex 4	ISLA Repair
WBA VDSL2	Annex 4	ISLA Provisioning

WBA VDSL2	Annex 5	Pricing and Billing
WBA VDSL2	Annex 6	Prepayment Terms Conditions
WBA VDSL2	Annex 7	OLO CPE (public version)

BIJLAGE 3 – REFERENTIEAANBIEDINGEN AANGEPAST OP 17 FEBRUARI

BRUO

(part 2)

Belgacom access to the Raw Copper Loop

Existing single pair & Small Network Adaptations

Annex B 1.1 Service Description 2010

Created on: 16 February 2012

belgacom

together with





together
with



1 Table of contents

1	Table of contents.....	2
2	Scope	3
3	Definition	3
3.1	Product definition of Raw Copper Circuit	3
3.2	Product definition of Small Network Adaptations	5
3.3	Small Network Adaptations	6
3.4	Network Termination Point	6
3.5	Type of Loops offered by Belgacom	7
4	Connectivity to the Beneficiary Network	8
5	Colocation	8
6	Spectrum Management and equipment aspects	8
7	Boundary conditions and prerequisites	8
8	Ordering of Raw Copper	9
8.1	Standard provisioning rules	9
8.2	Non-standard provisioning rules	14
9	Wrongful repair requests.....	15

2 Scope

1. This Service Description deals with the definition of services, equipment and application requirements and properties of the Belgacom offer for renting Raw Copper Loops and related Small Network Adaptations as described under Section 2, and procedures for ordering of and fault reporting to Belgacom with respect to the services described herein on the Raw Copper Circuit.

3 Definition

3.1 Product definition of Raw Copper Circuit

2. Raw Copper Loop or Raw Copper Circuit means a pair of fully metallic continuous unequipped copper wires on the section between Belgacom's Main Distribution Frame at the Belgacom Local Exchange and the Network Termination Point at the User's site. The Raw Copper Loop or Raw Copper Circuit can be delivered on a Non-active Loop or an active Loop.
3. Beneficiary has the right to gain access to an end-to-end Raw Copper Loop at Belgacom Local Exchange buildings, on the condition that that the requested copper pair is unequipped. A pair is equipped when load coils or Active Equipment (coupling, repeaters, correctors, etc.) are present in the relevant circuit/s. Belgacom will make an equipped pair unequipped when possible. In case that the equipped pair cannot be made unequipped, this will be proved to the Beneficiary. For the sake of clarity, pairs can not be made unequipped in case this equipment is dedicated to multiple users or in case this removal does impact in any possible way other services or Users. Beneficiary will have access to the Raw Copper Loop at the Main Distribution Frame level on which the Raw Copper Loop is terminated. It is further required that, in the scope of this Service Description, the Raw Copper Loop is existing and can be used without the need of severe network modification works. The Small Network Adaptations performed by Belgacom are described in Section 2.2 and 2.3.
4. The access to the Raw Copper Circuit at the Belgacom network side will be realized on the Belgacom Main Distribution Frame (MDF) by using dedicated Blocks per Beneficiary. The access to the Raw Copper circuit at the User site will be at the Belgacom Network Termination Point (NTP).
5. The Demarcation Point in case of Belgacom delivered Tie Cabling will be
 - in case of Physical or Virtual Colocation: the point on the Tie Cable just before it is connected to the collocated equipment of the Beneficiary.
 - in case of Distant Colocation: the Connectors in a Cross Connection Cabinet in the immediate vicinity of the Belgacom Local building.

6. The demarcation point in case of Beneficiary delivered Tie cabling shall be the Beneficiary dedicated Blocks on the MDF in case of Raw Copper. In case of Tie cabling delivered by the Beneficiary, the Beneficiary has access to the area where the demarcation point is situated (MDF area in case of Raw Copper) at the Belgacom Local Exchange or Local Distribution Center for maintenance and test purposes. Beneficiary shall have to justify the necessity of the maintenance and/or tests planned. Beneficiary shall have to indicate the purpose of this access substantially (to be mentioned with the application for guided access). The access shall always be with a security escort, at the expense of the Beneficiary, and pursuant the conditions for guided access as described in the framework of co-mingling (physical colocation with escort access).

8. It is further required that in the scope of this Service Description, the Raw Copper Circuit is existing and can be provided without new construction of physical copper wires in the network. The construction of new Raw Copper Circuits is outside the scope of this Service Description.

9. Establishment of a Network Termination Point (where relevant) and cross connections in the local access network between Distribution Cable and the Feeder Cable (where relevant) are part of the provisioning and installation of the Raw Copper Circuit under this Service Description.

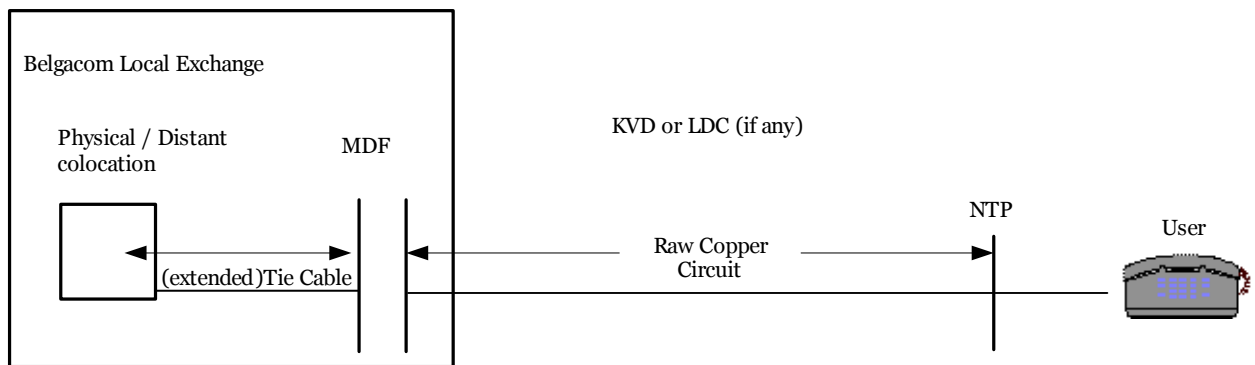

Fig. 1

3.2 Product definition of Small Network Adaptations

10. The Introduction Cable (also referred to as drop wire) is defined as the part of a Raw Copper Loop that connects the Distribution Cable to the User Network Termination Point.
11. In some cases, the pair of fully metallic continuous unequipped copper wires exists from the Belgacom Main Distribution Frame at the Belgacom Local Exchange up to the Distribution Cable in the street in front of the User premises.
12. The present Service Description establishes the terms and conditions under which Belgacom will perform Small Network Adaptations by means of drop wire construction or drop wire intervention.

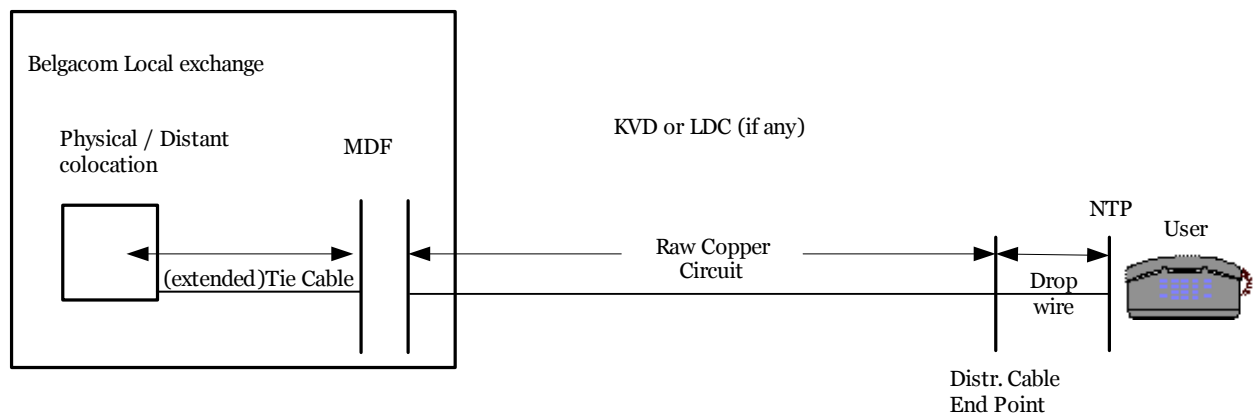

Fig. 2

3.3 Small Network Adaptations

13. In some cases, the pair of fully metallic continuous unequipped copper wires exists from the Belgacom Main Distribution Frame at the Belgacom Local Exchange up to the Distribution Cable in the street in front of the User premises.
14. In case no Introduction Cable is available for the provisioning of a Raw Copper Loop, the following solutions will be applicable:
 - Realization of a new introduction in the building of the Beneficiaries User
 - Renewal of the introduction in the building of the Beneficiaries User
 - Splicing additional pairs in the existing introduction splice of the building of the Beneficiaries User
 - Moving existing introduction from an existing Distribution Cable to another existing Distribution Cable.
15. These solutions will only be available upon specific request of the Beneficiary and providing that the Belgacom standard conditions for access are fulfilled. This requires that a free duct or an open trench is available on the private domain. If a free duct or an open trench is not available on the private domain, Belgacom can be asked to also perform this part of the work on condition that the Beneficiary agrees to pay the non-discriminatory commercial price for that part of the work performed by Belgacom. This price will be determined on a case by case basis.
16. Belgacom will only perform the Small Network Adaptations if the splicing is done in front of the premises of that specific User. Belgacom will provide an Introduction Cable with a standard length of 20 meters to provide connection between the Distribution cable and the Network Termination Point. In case an introduction with a length of more than 20 meters has to be provided, Belgacom will charge the Beneficiary the relevant price for the extra work.
17. In case no more free pairs are available in the Distribution Cable or the Feeder Cable, the request for Raw Copper Loops will be rejected. The construction or trenching of new distribution cabling, new street cabinets or new feeder cabling is outside the scope of the present offer.

3.4 Network Termination Point.

18. If no Network Termination Point is present, such Network Termination Point will be installed by Belgacom. This is automatically the case for Small Network Adaptations. New internal cabling must always, except when specified otherwise, be provided by Belgacom, or under his responsibility, if existing internal cabling is insufficient in capacity of free pairs or of poor quality.

19. The attention is drawn to the fact that Belgacom reserves the right to propose to BIPT (which will decide on their implementation) on a non-discriminatory basis various scenarios to provide an adequate answer to the situation in which a cable (sometimes referred to as internal cabling) is placed between the Network Termination Point and the Introduction Cable. Such an answer is to be developed on a case-by-case basis and would need to take into account, in particular and where relevant, the presence of an introduction box, the way of introducing the Raw Copper Loop in the building of the User, the specific status of the cabling, the nature of the building and/or the work to be accomplished to offer the Service.
20. The current way of working will be evaluated after the necessary experience has been obtained by all Parties in the installation of Raw Copper Loops and Circuits. Belgacom will re-evaluate the offer and reserves the right to propose the necessary modifications on this item.

3.5 Type of Loops offered by Belgacom

21. The following types of Raw Copper Loops are offered under the present Reference Offer for ULL (for technical details concerning the nature of the signals to be used on each type of Raw Copper Loops, see the Technical Specifications Document that can be found in Annex C):
 - Raw Copper Loops of Type 1: Basic Raw Copper Loop only to be used for the transmission of signals (including and starting from direct current) within the voice frequency band, being PSTN or Raw Copper Loop only to be used for the transmission of signals for which the binary rate is smaller or equal to 64 kbit/s or for the transmission of signals using ISDN basic access line code.
 - Raw Copper Loops of Type 2: Raw Copper Loop to be used According to the rules of the technical specifications document (annex c). The Beneficiary can also use the Raw Copper Loop like Type 1, obviously.
22. In ordering, Beneficiary indicates the type of loop per qualification as described above. Belgacom will handle requests for Type 1 as PSTN and Type 2 loops will by default be treated as ADSL over PSTN with respect to matters of repair and the quality of service related to the repair requests. Belgacom will not bear any liability relating to the absence of qualification of the loop when the loop qualification (e.g. Type 1 PSTN, Type 1 ISDN, Type 2 ADSL, Type 2 SDSL) was not included with the repair request. If this qualification is different from the default documented qualification as above, Beneficiary is invited to specify the service residing on the loop if this is necessary to facilitate the repair process.
23. The use of a totally unbundled Loop is free, provided that the Beneficiary complies with the “Spectrum Management” rules. The “Spectrum Management” rules regarding Unbundled Loops are described in Annex C to the present Reference Offer. Rules for “Spectrum Management” can be proposed by the Task Group Spectrum Management or BIPT and can be added to the Annex C of the present Reference Offer.

24. Depending on the type of equipment that is directly connected to the unbundled Local Loop, different rules for the bringing into service and for the service level can be applicable.

4 Connectivity to the Beneficiary Network

25. At the Belgacom Local Exchange building, the copper wires are terminated on the Main Distribution Frame. Beneficiary's access to the copper wire pairs will be established by connecting Tie Cables from the Main Distribution Frame to the colocation area in case of physical colocation and by connecting Extended Tie Cables from the Main Distribution Frame to the Cross Connection Cabinet in case of distant colocation.
26. The installation and maintenance of the (Extended) Tie Cable and the provisioning and maintenance of the Blocks will be made by Belgacom, as presented in Service Descriptions 2030 and 2035.

5 Colocation

27. For the provision of Colocation Services reference is made to the Colocation Agreement. Subscriptions to this agreement is a pre-requisite to install equipment in a Belgacom building. For the sake of clarity, Colocation Services can only be used to benefit from specific Belgacom Services requiring colocation.

6 Spectrum Management and equipment aspects

30. "Annex C: Technical Specifications Document" to the contract, contains requirements related to Spectrum Management and equipment connected to the Raw Copper pair.

7 Boundary conditions and prerequisites

31. The Beneficiary is only allowed to use the indicated type of Raw Copper Loop for the purpose described in Section 2.5. In any case of changes by the Beneficiary of the equipment/technology used, the Beneficiary will inform Belgacom of this fact in order to avoid service degradation in the Belgacom Network for other Users.

32. At all times, the coexistence needs to be ensured between the services provided by the Beneficiary through the use of the Raw Copper Loops and the services provided by Belgacom or another Beneficiary on the Belgacom Network. In particular, Belgacom will be entitled to take a number of measures to protect its network integrity taking into account the need to ensure the coexistence of the different services mentioned above. In this case Belgacom will take measures either after prior approval by BIPT, either immediately in urgent cases. In the latter case, BIPT will be informed at the latest the next working day on the measures taken. Belgacom will inform and justify the Beneficiary as soon as possible on the measures taken. In all cases, Belgacom will follow the rules regarding spectrum management.
33. All equipment used by the Beneficiary will at least comply with the R&TTE Directive.
34. It is noted that Belgacom will not undertake customer care handling of End Users of the Beneficiary. If Belgacom receives requests from Users of the Beneficiary due to the inadequate handling of such requests by the Beneficiary, Belgacom will not deal with them.
35. In case there is a change of Raw Copper Loop type, the Beneficiary will address a request for a deactivation and an installation to Belgacom, in order to obtain the requested modification.
36. If Belgacom can demonstrate that if equipment or network components, that are operated by Beneficiary for its own use and that are connected to Belgacom's public telecommunications network, cause disturbances in Belgacom's network, Beneficiary shall be required to disconnect the User connection without any delay.

8 Ordering of Raw Copper

37. Belgacom shall deliver access to the Raw Copper according to Beneficiary's orders transmitted to Belgacom. The general terms and conditions for delivering Raw Copper Loops are defined in "Annex E: Planning and Operations manual".
38. The full details of the provisioning process can also be found in "Annex E: Planning and Operations manual".

8.1 Standard provisioning rules

39. Beneficiary orders and ends a Raw Copper Service by means of the electronic order form. See Annex E "Planning and Operations Manual" for more details.

40. The Beneficiary can obtain the following Standard Raw Copper Services

<i>Service in respect of Raw Copper</i>	<i>Description</i>	<i>Fee</i>
1. <i>Inquiry</i>	<i>Examination of whether a Raw Copper (Sub-)Loop can be provided end to end</i>	<i>Inquiry fee</i>
2. <i>Request for a Raw Copper (Sub-)Loop</i>	<i>Physical cross connection of the Raw Copper (Sub-)Loop to the Beneficiary's Tie Cable at the Main Distribution Frame of the Belgacom Local Exchange, as well as - if necessary - related work at the User's site</i>	<i>Activation fee</i>
3. <i>Cancellation of a Request for a Raw Copper (Sub-)Loop</i>	<i>Orders that have been placed by the Beneficiary but that are cancelled prior to implementation</i>	<i>Cancellation fee</i>
4. <i>Installation of an NTP if necessary</i>	<i>Belgacom installs a Network Termination Point at the User's premises side</i>	<i>Telecom installation fee, invoiced on top of the activation fee</i>
5. <i>Deactivation of a Raw Copper (Sub-)Loop</i>	<i>Belgacom disconnects the related copper wires from the Beneficiary's dedicated Blocks</i>	<i>Deactivation fee</i>
6. <i>Change date</i>	<i>The Beneficiary requests a change in due date for the provisioning of a Raw Copper loop</i>	<i>Change date fee</i>
7. <i>Transfer¹</i>	<i>Transfer of a Raw Copper (Sub-)Loop from Beneficiary 1 to Beneficiary 2</i>	<i>Physical migration fee, billed to Beneficiary 2</i>

¹ See chapter 9: Migrations

Further comments:

(1) Inquiry

41. The purpose of an inquiry is to investigate the availability of an end-to-end Raw Copper Loop at a particular User site. For Type 2 loops, Belgacom will additionally perform a pair selection test to verify that the service can coexist with the surrounding pairs. An inquiry gives only the status of a Raw Copper Loop in relation to a specific User at one specific moment in time. Belgacom guarantees the accuracy of the information provided at the moment of the inquiry, without prejudice to any subsequent change in the technical situation.

(2) Request for a Raw Copper Loop:

42. There are three possible situations, depending on the impact of the provision of Raw Copper (Sub-) Loops to the Beneficiary on the contractual relation between the User and Belgacom:
 - The Raw Copper Loop Request concerns a Non-active Loop and therefore does not affect the existing relation between Belgacom and the User. This is only possible if there is a (Non)-active Loop available at the User's premises.
 - The Raw Copper Loop Request concerns an Active Loop and therefore affects the existing relation between Belgacom and the User. This Request is also called a *Migration*.
 - The Raw Copper (Sub)-loop Request implies a small network adaptation (see 2.3).

Inquiry

43. In case the Beneficiary places a firm order for a Type 1 Raw Copper Loop as defined above, Belgacom will carry out an inquiry to determine whether a Non-active Loop exists between the User and the Belgacom Local Exchange (as indicated by the Beneficiary). For the firm order of a Type 2 Raw Copper Loop as defined above, Belgacom will perform additionally a pair selection test to verify whether the service, as indicated by the Beneficiary, can coexist with the surrounding pairs.

Rejection for technical reasons

44. In case the order cannot be implemented because of technical reasons, which has to be detailed and proved to the Beneficiary, the Beneficiary's Request will be rejected. In this case, the Beneficiary will be billed for the work done by Belgacom on validation of that order. If the firm order can be implemented, Belgacom will proceed with the implementation of that order according to the applicable process, which can be obtained at the Belgacom contact point mentioned above.

NTP installation

45. Belgacom will install an NTP, as termination point on the Raw Copper Loop, if such an NTP does not exist (see 2.4).

In case of Migration

46. In the case of a Migration, the user has the right to cancel an existing service that is currently made available to the User by Belgacom according to his contractual relationship with Belgacom. The services that can be terminated are the following: a single line PSTN service, a single line ISDN service or any other service (including a leased line). In such a case, Belgacom will ensure that the cancellation of the existing Belgacom Services and the provisions of the Raw Copper will take place on the same day, not exceeding 4 hours. In case the Raw Copper (Sub-)Loop between the User and Belgacom exists less than one year, the User may be billed by Belgacom an extra charge for the Migration of that specific loop.

In case of Number Portability

47. In case of a request for Migration, the Beneficiary has also the possibility to request Belgacom to provide the porting of the User numbers in case the User formerly had a single line PSTN or ISDN service with Belgacom. In this case, there is an interaction with the Number Portability (NP) process, for which the Beneficiary will need to comply with the relevant procedures. The Beneficiary needs to introduce first an order for NP and later one for Raw Copper. In ordering Raw Copper, the Beneficiary Requested Date that is always provided by Beneficiary, need to match the requested execution date for Number Portability. Beneficiary will respect the rules for a Migration of Raw Copper and the procedures for number portability. In case there is a number portability request, the Beneficiary will indicate the numbers currently used by the User, which have to be ported to the Beneficiary on the Raw Copper Loop concerned.
48. In case NP is involved in the Migration, the Beneficiary will indicate that on the request form. If the User has a single line PSTN service with Belgacom, the Beneficiary is required to use the existing NTP that will not be removed by Belgacom. If the User has a single line ISDN service with Belgacom, the existing NTP will be removed by Belgacom and replaced with a TF95 or other device. These rules are not applicable in case the NTP is a cross-connectable distribution box where multiple pairs are connectable for that User.

In case of Small Network Adaptations

1. Beneficiary has the possibility to indicate 'SNA not allowed' when ordering. If 'SNA not allowed' is flagged when ordering, Belgacom will send a reject of the order should the need for a SNA be established at any point in the provisioning phase.

2. In case the order is not flagged ‘SNA not allowed’, the process is as follows:

a. If a Small Network Adaptation need is detected during the order validation,

Belgacom will notify this into the XML VALIDATE message by communication in the remark type SmallNetworkAdaptations the word “NEEDED”.

b. If a SNA need is detected during provisioning,

Belgacom will create a HOLD message where a new appointment date will be proposed and with in the remark type SmallNetworkAdaptations the word “NEEDED”.

In both cases, the Beneficiary can then contact its End User for further negotiations.

(3) Cancellation of a Request for a Raw Copper Loop

49. The Beneficiary has the right to cancel an order that the Beneficiary has submitted to Belgacom for the implementation of a Raw Copper Loop. However, Belgacom will bill the Beneficiary for the work done in the process.

(4) Installation of an NTP if necessary

50. The circumstances under which an NTP is to be installed by Belgacom are described in point 2.1.3.

(5) Deactivation of a Raw Copper Loop

51. The Beneficiary can request the Deactivation of the Raw Copper Loop at a particular User site.

(6) Changed Use of a Raw Copper Loop

52. When the Beneficiary intends to use the Raw Copper Loop for other purposes than intended at the time of the first order, the Beneficiary will communicate the change of types to Belgacom (from Type 1 to Type 2 or vice versa). Belgacom then can take the necessary measurements for the changed use of that Raw Copper Loop. In addition, Belgacom reserves the right to reject the request of changed use for technical reasons in case the Raw Copper Loop cannot be provisioned in accordance with the request for changed use of the Beneficiary.

(7) Change Date

53. The Beneficiary will indicate on the order form the date at which the Beneficiary wishes Belgacom to provide the Raw Copper Loop (referred to as "Requested Installation Date" or "RID"). The Beneficiary has the right to change that date. In the latter case, the Beneficiary will be billed a Change Date fee.

(8) Transfer

54. When there is a transfer from Raw Copper Loops from Beneficiary 1 to Beneficiary 2, it is presumed that two Beneficiaries, according to agreement with the User, handle the removal of the User's services and co-ordinate the hand over of the Raw Copper.
55. It is acknowledged that Belgacom will transfer the Raw Copper Loop from Beneficiary 1 to Beneficiary 2 upon request of Beneficiary 2 solely. Belgacom will terminate the contract for that specific Raw Copper Loop by informing Beneficiary 1 of the request from Beneficiary 2, without revealing the identity of Beneficiary 2.
56. Belgacom handles the request of the Beneficiary 2, taking over the Raw Copper. Belgacom does not in any case handle complaints between Beneficiary 1 and Beneficiary 2.
57. The above services (listed under (1) to (8)) are settled according to the prices indicated in Annex H. For the installation fee, different price setting can apply to different types of Raw Copper Loops and different types of installations based on the work performed by Belgacom after approval by BIPT.

8.2 Non-standard provisioning rules

58. Belgacom will reject a Request for Raw Copper Loop, in particular:
 - if no Non-active Loops are available (in case of a Request for a Non-active Loop); without prejudice of the right of the Beneficiary to request in that case a small network adaptation by Belgacom, according to the conditions as set out in Section 2
 - if no Migration is possible due to technical constraints which must be detailed and proved to the Beneficiary in the implementation of the existing User connection;
 - if the requested service is incompatible with the applicable pair selection rules as defined in annex C: Technical Specifications document;
 - if no positions and/or pairs are available on the Beneficiary Blocks or Tie Cables in case of Physical colocation, or if no positions and/or pairs are available on the Beneficiary Blocks and Connectors or Extended Tie Cables in case of Distant colocation.
59. In case a Migration cannot be executed, the Beneficiary Request will be rejected. However, in that case the Beneficiary has the possibility to send to Belgacom a Non-active Loop Request. In the event that the latter Request can also not be executed, this Request will also be rejected.

9 Wrongful repair requests

60. Belgacom's fault repair of the Raw Copper between the Main Distribution Frame at the Belgacom Local Exchange building and the User NTP is included in the periodic payment for the Raw Copper Loop. The procedures for that fault reporting are described in "Annex E: Planning and Operations manual".

61. In case of a repair request where the fault was not caused by Belgacom and Belgacom has performed work for that repair request, Belgacom reserves the right to bill the Beneficiary for the work done by Belgacom in light of that specific request according to "Annex H: Price list" It is noted that Belgacom in a first phase will not automatically charge the Beneficiary for wrongful repair requests.

Belgacom access to the Raw Copper Loop

Connection to the collocation area

Physical Colocation

Annex B 1.2 Service Description 2030

Created on: 16 February 2012

belgacom



1. Table of contents

1	Table of contents.....	2
2	Scope	3
3	Definition of the service	3
4	Colocation	5
5	Provisioning of blocks and Tie Cables	5

2. Scope

1. This Service Description deals with the definition of the service, equipment and application requirements for the connection of the Raw Copper Loops to the colocation space of Beneficiary, whereby Belgacom delivers the Tie Cables and Blocks.

3. Definition of the service

2. At the Belgacom Local Exchange building, the copper wires are terminated on the Main Distribution Frame. Beneficiary's access to the copper wires will be established with Tie Cables from the Main Distribution Frame of the Local Exchange building to Beneficiary's colocation area in that same Belgacom Local Exchange building.

Belgacom Local Exchange Building

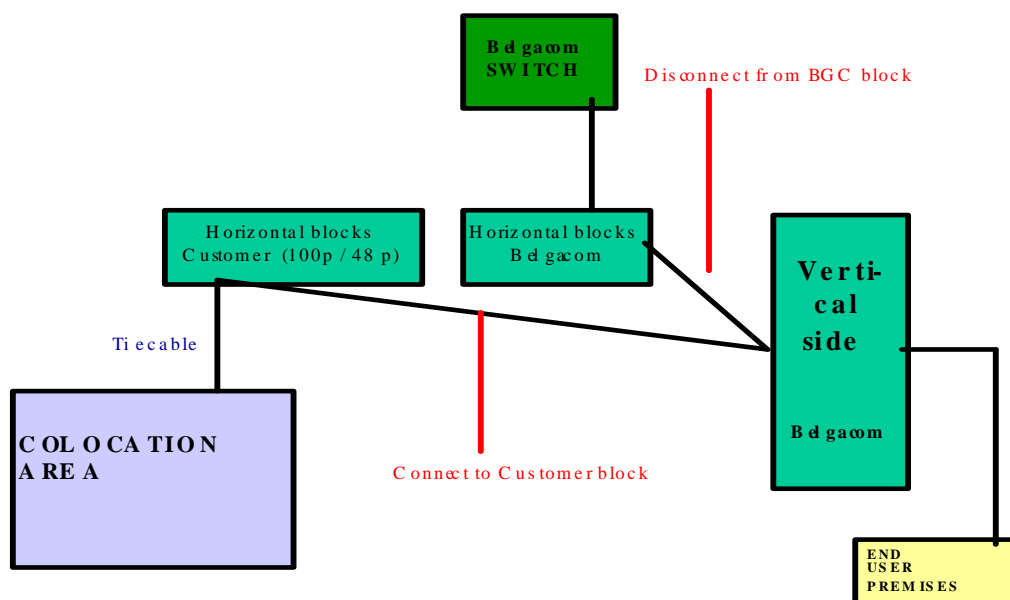

Fig. 1

3. Beneficiary will order the Tie Cables and connection blocks at Belgacom's Local Exchange building prior to the request of Raw Copper Loops. This ordering process is described in "Annex E: Planning and Operations manual".*
4. If at a certain moment, no more free wires are available in the Tie Cables or no more free space is available on blocks, the specific Raw Copper Loop requests issued by the Beneficiary will be rejected, since provisioning of that Raw Copper Loop cannot be implemented.
5. Standard default order:

The default standard unit that Beneficiary can order for the provisioning between blocks on the MDF and the colocation area are:

- 48 pairs for Type 2 loop with an increment of 2 blocks and associated cables: the blocks on the MDF will be two 48 pair blocks and the Tie Cables 4*24 pair shielded cables
- 100 pairs for the Type 1 loop with an increment of 1 block and associated cables: the block on the MDF will be a 100 pair block and the Tie Cables 1*100 pairs non-shielded cable or VVT cable.

6. Non-standard order:

Upon specific request of the Beneficiary, the incremental unit of ordering can be lowered to

- either 48 pairs for Type 2 loop with an increment of 1 block and associated cables: the block on the MDF will be a 48 pair block and the Tie Cables 2*24 pair shielded cable
 - either 48 pairs for Type 2 loop with an increment of 1 block and associated cables: the block on the MDF will be a 48 pair block and the Tie Cables a 1*24 pair shielded cable. (The attention is drawn to the fact that the latter type of increment is subject to further investigation within Belgacom. Operational and documentation issues may therefore cause a longer provisioning delay than the ones indicated in the other related and relevant documents.)
7. The request for this lower increment must be explicitly notified to Belgacom. The prices for this lower increment can be found in "Annex H: Price list".

* The Annex will be provided to the requesting Beneficiary as soon as it will be available.



together
with



4. Colocation

Physical Colocation is a prerequisite for the implementation of this Service Description. The installation and maintenance of colocation will be made by Belgacom, as presented in the “Belgacom Physical Colocation Agreement” attached to this Agreement.

5. Provisioning of blocks and Tie Cables

8. Reference is made to “Annex E: Planning and Operations manual”.

Product	Comments
1. 48 pair blocks for the provisioning of Type 2 loops.	Default ordering per increment of 2
2. 24 pair shielded cable for the provisioning of Type 2 loops.	Default ordering per increment of 4
3. 100 pair blocks for the provisioning of Type 1 loops	Ordering per increment of 1
4. 100 pair non-shielded cable or VVT cable for the provisioning of Type 1 loops.	Ordering per increment of 1

Note: The above services are settled according to “Annex H: Price list”.

Belgacom access to the Raw Copper Loop

Connection to the colocation area

Distant Colocation

Annex B 1.3 Service Description 2035

Created on: 16 February 2012

belgacom

together with





together
with



1 Table of contents

1	Table of contents.....	2
2	Scope	3
2.1	Definition	3
2.2	Provisioning of blocks and Extended Tie Cables	4
3	Description of the Cross Connection Cabinet	5
3.1	Definition	5
3.2	Provisioning of modules	6
4	Jumpering in the Cross Connection Cabinet.	7

2 Scope

This Service Description deals with the definitions, equipment and application requirements for the connection of the Raw Copper Loop to the Cross Connection Cabinet of Beneficiary, whereby Belgacom delivers the all mentioned equipment.

2.1 Definition

At the Belgacom Local Exchange building, the copper wires are terminated in the Main Distribution Frame. Beneficiary's access to the copper wire will be established with Extended Tie Cables from the Main Distribution Frame of the Local Exchange to the dedicated Beneficiary's Cross Connection Cabinet at the outside wall of that Local Exchange building.

Belgacom Local Exchange Building

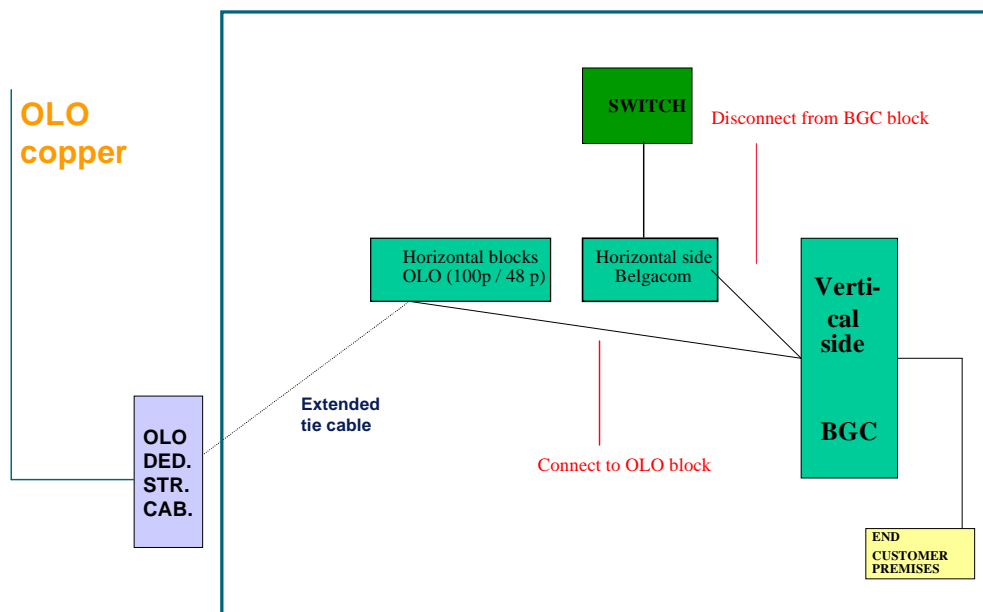

Fig. 1

Beneficiary will order the Extended Tie Cables and connection blocks at Belgacom's Local Exchange building prior to the request of Raw Copper Loops. This ordering process is described in "Annex E: Planning and Operations manual".

If at a given moment, no more free wires are available in the Extended Tie Cables or no more free space is available on any of the Beneficiary blocks, the specific Raw Copper Loop requests issued by the Beneficiary will be rejected.

Standard default order:

The default standard unit that Beneficiary can order for the provisioning between blocks on the MDF and the colocation area are:

- 48 pairs for Type 2 loop with an increment of 2 blocks and associated cables: the blocks on the MDF will be two 48 pair block and the Tie Cables 4*24 pair shielded cables
- 100 pairs for the Type 1 loop with an increment of 1 block and associated cables: the block on the MDF will be a 100 pair block and the Tie Cables 1*100 pairs non-shielded cable or VVT cable.

Non-standard order:

Upon specific request of the Beneficiary, the incremental unit of ordering can be lowered to

- either 48 pairs for Type 2 loop with an increment of 1 blocks and associated cables: the block on the MDF will be a 48 pair block and the Tie Cables 2*24 pair shielded cable
- either 48 pairs for Type 2 loop with an increment of 1 blocks and associated cables: the block on the MDF will be a 48 pair block and the Tie Cables 1*24 pair shielded cable. (The attention is drawn to the fact that the latter type of increment is subject to further investigation within Belgacom. Operational and documentation issues may therefore cause a longer provisioning delay than the ones indicated in the other related and relevant documents.)

The request for this lower increment must be explicitly notified to Belgacom. The prices for this lower increment can be found in "Annex H: Price list".

2.2 Provisioning of blocks and Extended Tie Cables

Reference is made to "Annex E: Planning and Operations manual".

Product	Comments
1. 48 pair blocks for the provisioning of Type 2 loops.	Default ordering per increment of 2
2. 24 pair shielded cable for the provisioning of Type 2 loops.	Default ordering per increment of 4
3. 100 pair blocks for the provisioning of Type 1 loops	Ordering per increment of 1
4. 100 pair non-shielded cable or VVT cable for the provisioning of Type 1 loops.	Ordering per increment of 1

Note: The above services are settled according to "Annex H: Price list".

3 Description of the Cross Connection Cabinet

3.1 Definition

The existence of a Cross Connection Cabinet is a prerequisite for the implementation of this Service Description. The construction of the Cross Connection Cabinet is outside the scope of this agreement. The modules and the cable from these modules in the lower part of the Cross Connection Cabinet will be spliced on the cable from the Beneficiary according to the relevant provisions in the “Belgacom Distant Colocation Agreement”.

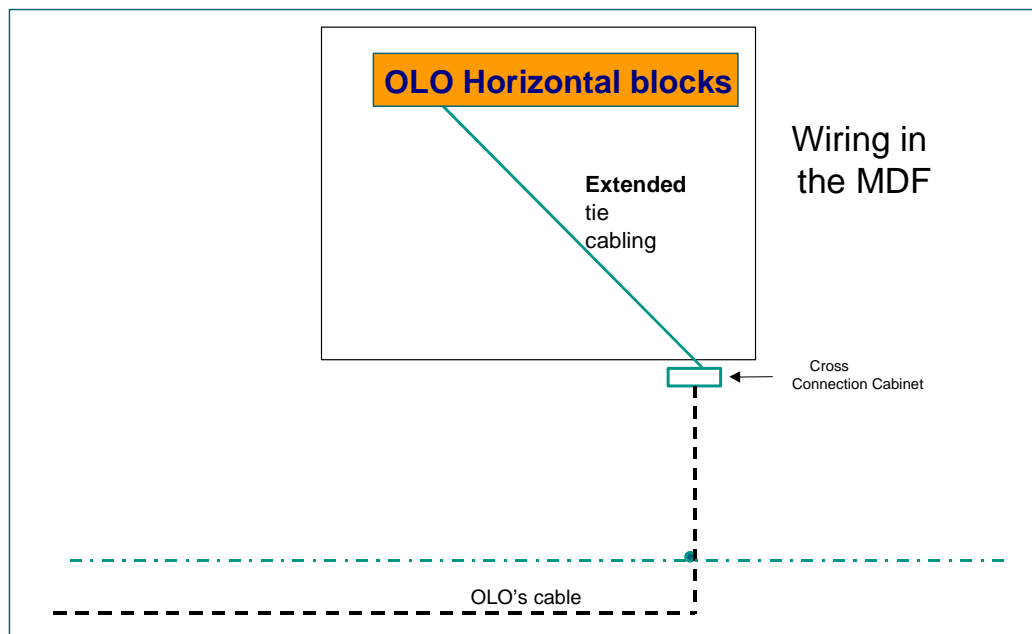

Fig. 2

Beneficiary will order the modules in the Cross Connection Cabinet prior to the request of Raw Copper Loops. This ordering has to be done at the same moment as the ordering of the blocks and the extended tie cabling to connect the MDF. The process is described in “Annex E: Planning and Operations manual”.

If at a certain moment, no more free space is available on the Cross Connection Cabinet blocks, the specific Raw Copper Loop requests issued by the Beneficiary will be rejected.

3.2 Provisioning of modules

Standard Order

The modules are composed of connectors. The unit that Beneficiary can order are:

- 96 connectors type LSA + (a+b+s) for Type 2 loops
- 100 connectors type LSA (a+b) for Type 1

Non-standard order:

Upon specific request of the Beneficiary, the incremental unit of ordering Connectors can be lowered to

- 48 connectors type LSA + (a+b+s) for Type 2 loops

Reference is made to “Annex E: Planning and Operations manual”.

Product	Comments
5. 96 connectors type LSA + (a+b+s) for Type 2 loops	Ordering per increment of 1
6. 100 connectors type LSA (a+b) for Type 1 loops	Ordering per increment of 1

Note: The above services are settled according to “Annex H: Price list”.

4 Jumpering in the Cross Connection Cabinet.

As indicated above, the Beneficiary will be responsible for handing over the necessary cable with the required distance to Belgacom and will be responsible for bringing the cable up to the Cross Connection Cabinet and connecting the Beneficiary cable to the lower blocks in the Cross Connection Cabinet.

The Beneficiary is further responsible for dimensioning the cable and selecting the pairs within the Beneficiary cable.

Belgacom will not be responsible for jumpering between the upper blocks and the lower blocks in the Cross Connection Cabinet. Belgacom can also not be held responsible for any disturbances caused in the signal due to the choice between the pairs in the external Cable provided by Beneficiary going to the Beneficiary premises.

Belgacom access to the Raw Copper Services

Technical Specifications

Annex B 1.4 & B 2.4 Service Description 2040 & 3040 - Appendix A

Created on: 16 February 2012

belgacom

together with





together
with



1 Table of contents

1	Table of contents.....	2
2	Technical Specification for the delivery of a shielded twisted 24 pairs cable.....	3
2.1	Introduction.....	3
2.2	Description of the cable	3
2.3	Electrical Features.....	4
2.3.1	Electrical requirements of the conductor	5
2.3.2	Insulating resistance	5
2.3.3	Dielectric strength.....	5
2.3.4	Cable impedance	5
2.3.5	Attenuation.....	5
2.3.6	Crosstalk between 2 pairs	5
2.3.7	Mutual capacitance	5
2.3.8	Capacitance unbalance	5
3.	Technical Specification for the Reel	6

2 Technical Specification for the delivery of a shielded twisted 24 pairs cable

2.1 Introduction

1. This document specifies the properties of the cable used for connecting the Main Distribution Frame to the Colocation Area in the local exchange. It is an extract of the Belgacom technical specification used when purchasing this type of cable. Some characteristics of the purchased cable may be other than those required in this specification, but the electrical requirements are always maintained.

2.2 Description of the cable

2. The cable is respectively made of: 24 symmetrical pairs, each of them having the following characteristics:
3. Conductor: a mono-conductor wire of 0.5 mm (\pm 0.01 mm) diameter made of annealed copper, single strand, circular in section, and tinned.

1	white	blue
2	white	orange
3	white	green
4	white	brown
5	white	grey
6	red	blue
7	red	orange
8	red	green
9	red	brown
10	red	grey
11	black	blue
12	black	orange
13	black	green
14	black	brown
15	black	grey
16	yellow	blue
17	yellow	orange
18	yellow	green

19	yellow	brown
20	yellow	grey
21	white-blue	blue
22	white-blue	orange
23	white-blue	green
24	white-blue	brown

4. Insulation: a full polyvinyl chloride insulating coat of 0.20 mm thickness (0.17 mm minimum) and with a nominal external diameter of 0.90 [+0.05 mm, -0.03 mm]. The colours shall correspond with IEC 189-2 App. A and IEC 304.
5. The cabling element is a pair of two insulated conductors designated wire A and wire B. Twisting pitch of the pair: 50mm maximum.
6. The 24 cabling elements are stranded in concentric layers. A binding tape is placed between successive layers. The sequence of elements is from the centre to the outside layer; the counting direction is clockwise and the same in each layer.
7. The core of the cable is wrapped with a protective layer of non-hygroscopic material, wound helical or longitudinal lapping and consists of 1 or 2 tapes with overlap.
8. A tinned copper wire with the same dimensions as the conductor wires is included in the cable in continuous contact with the surface of the screening foil.
9. A screening foil consists of a sandwich foil aluminium-insulated tape-aluminium with an aluminium thickness of 25 microns on both sides. The tape is applied longitudinally round the wrapped core with an overlap of 6 mm minimum.
10. A braid shield of tinned copper wires, forming a screen with a minimum coverage ratio of 50 %, is placed around the preceding elements. The diameter of the single wires is between 0.10 mm and 0.20 mm.
11. A thread of non-hygroscopic material denoting company of manufacture is laid underneath the sheath.
12. A monochrome grey (RAL 7032, colored in the block) sheath in LSZH material is enveloping the previous assembly. Sheath thickness: 0.80 mm nominal, 0.60 mm minimum. The diameter of the finished cable does not exceed 11.5 mm.
13. On the surface of the coating, the following indications are printed with permanent black (or dark blue) ink: SP XXX (to be later defined) - NAME OF THE MANUFACTURER (MANUFACTURING YEAR).
14. Under or after this metrical indication, an indexed number allows to measure easily the length of a cable part by making the difference of two indexes.

0 1 2 3 4 5 6 ...

2.3 Electrical Features

2.3.1 Electrical requirements of the conductor

15. The loop resistance is maximum 196.5 ohm/km at 20°C and the conductivity is minimum 57 m/ohm.mm² at 20°C.

2.3.2 Insulating resistance

16. The insulating resistance between the two wires of the pair or between each wire and the screen is not inferior to 500 Megohm x kilometer after a minute of electrification.

2.3.3 Dielectric strength

17. The dielectric strength is minimum 1500 Vdc when measured during 1 minute.

2.3.4 Cable impedance

18. The cable impedance is in the range 80-110 ohms at 1 MHz.

2.3.5 Attenuation

19. At 1 Mhz, the attenuation may not exceed 32 dB/km.

2.3.6 Crosstalk between 2 pairs

20. The near end and far end crosstalk values (between two symmetrical pairs under the screen placed side by side on a length of 250 meters) are greater than 55 dB at 1 MHz and 40 dB at 10 MHz

2.3.7 Mutual capacitance

21. The mutual capacitance is maximum 100 nF/km measured between 500 and 2000 Hz.

2.3.8 Capacitance unbalance

22. Between any pair and the earth the capacitance unbalance does not exceed 750 pF/500m with the exception of 1 value of the values up to 1500 pF/500m at 1 kHz.

3 Technical Specification for the Reel

23. Belgacom accepts reels with a maximum diameter of 1 meter. This as the installations teams handle the reels manually to transport it up to the relevant floor in the Local Exchange building. In case more reels are delivered on a site, they need to be placed one next to another (no piling).

Belgacom access to the Raw Copper Services

Length of Tie Cabling per LEX

Annex B 1.4 & B 2.4 Service Description 2040 & 3040 - Appendix B

Created on: 16 February 2012

belgacom

together with





together
with



1 Table of contents

1	Table of contents.....	2
2	Tabel.....	3

2 Tabel

The information included in the sheet “lengths” refers to the lengths in scope of Tie Cabling as documented by Belgacom. These lengths are applicable only in case of Belgacom physical collocation – separate Beneficiaries Room with Badge access.

NET Name	Type	Distance		
		RC	SP (Splitter to Colo)	SP (Splitter to MDF)
03BAC/03BKC	AGE Only	NA	NA	NA
41GRE	AGE Only	NA	NA	NA
91GKK	AGE Only	NA	NA	NA
02MAR	AGE+LEX	150	135	12
02STR	AGE+LEX	250	250	20
03CEN	AGE+LEX	180	150	30
11HAS	AGE+LEX	75	80	15
16LEU	AGE+LEX	80	95	18
41LGE	AGE+LEX	180	40	
50ASS	AGE+LEX	95	60	58
56KOR	AGE+LEX	75	50	47
65MON	AGE+LEX	88	88	
71GIL	AGE+LEX	60	80	60
81MAH	AGE+LEX	190	190	
81NAM	AGE+LEX	115	115	
91GEN	AGE+LEX	60	74	16
02UKK - LDC 599	LDC	15		
02WEM - LDC 099	LDC	15		
02ALS	LEX	44	54	15
02AND	LEX	48	35	18
02BER	LEX	58	29	12
02BOS	LEX	40	52	15
02BRA	LEX	40	35	25
02CEN	LEX	29	33	10
02DRO	LEX	61	52	15
02EUR	LEX	67	66	22
02EVE	LEX	46	40	13
02GEN	LEX	53	45	15
02GIL	LEX	65	62	15
02GRI	LEX	95	53	20
02IXE	LEX	107	107	20
02JET	LEX	72	50	15
02LIN	LEX	39	39	31
02MOL	LEX	65	40	31
02MUT/02NOH	LEX	40	46	15



together
with



02NOR	LEX	44	48	15
02OBS	LEX	76	76	14
02OVE	LEX	46	30	16
02SAC	LEX	85	40	20
02SCH	LEX	95	112	30
02TVU	LEX	32	36	18
02UKK	LEX	65	71	14
02VIL	LEX	57	64	17
02WAT	LEX	59	55	15
02WEM	LEX	63	70	15
02WEZ	LEX	69	57	22
02WOL	LEX	56	54	21
03BER	LEX	85	70	15
03BOO	LEX	50	40	15
03BOR	LEX	20	20	20
03DEU	LEX	40	30	10
03HAV	LEX	60	50	10
03KAP	LEX	50		
03KON	LEX	40	30	10
03LIE	LEX	50		
03MER	LEX	50	40	20
03NIK	LEX	50	35	15
03OUD	LEX	50	35	20
03PUU	LEX	50	20	30
03SHO	LEX	35		
03SIL	LEX	30	20	10
03WIL	LEX	30	20	10
03ZUI	LEX	70	25	40
10LIM	LEX	32	32	
10WAV	LEX	31	31	
12TON	LEX	80		
14TUR	LEX	35	25	15
15MEM	LEX	75	60	15
15MES	LEX	60	40	20
16AAR/16ART	LEX	26	15	20
16KES	LEX	28	25	15
16TIE	LEX	28	22	12
41ANS	LEX	80	80	
41CHE	LEX	90	90	
41GUI	LEX	70	70	
41HER	LEX	90	25	
41LON	LEX	50	40	
41MAR	LEX	70		
50BRG	LEX	55		
51ROE	LEX	45		
52DEN	LEX	70		
53AAL	LEX	70		
54NIN	LEX	50		



together
with



56HAR	LEX	50	35	36
56HEU	LEX	70		
56MOU	LEX	39	39	
56WAR	LEX	53		
56WEV	LEX	49		
59OOS	LEX	45		
64LAL	LEX	80	80	
67NIV	LEX	70	70	
69TOU	LEX	70	70	
71CHA	LEX	100	100	
71CHT	LEX	28	24	
71GOS	LEX	37	37	
71MAR	LEX	56	56	
87VER	LEX	65	65	
89GEN	LEX	70		
91AMA	LEX	50	58	16
91GBR	LEX	50	32	18
91PIE	LEX	50	52	24
91ROO	LEX	50	56	18
91WET	LEX	60	64	14

Belgacom access to the Raw Copper Services

Delivering of Tie Cable by Beneficiary

Annex B 1.4 Service Description 2040

Created on : 16 February 2012

belgacom

together with





together
with



1 Table of contents

1	Table of contents.....	2
2	Scope	3
3	Definition of service.....	3
4	Ordering Infrastructure.....	5
4.1	General	5
4.2	Prerequisites	5
4.3	Ordering procedure.....	6
5	Specific Conditions	7
5.1	Type of cable.....	7
5.2	Identification of cable.....	8
5.3	Length of cable	8
5.4	Cable delivered on reel	9
5.5	Place where to deliver the cable	9
5.6	Appointment to deliver the cable	9
5.7	Receipt of goods	10
5.8	Remove empty reel	10
6	Prerequisite for the installation of Tie Cable delivered by Beneficiary	11
7	Fault Reporting and Repair.....	12
8	Ownership and responsibilities	13
9	Financial conditions	14

2 Scope

1. This document deals with the definition of the service, equipment and application requirements for the delivering of Tie Cable by Beneficiary in case Beneficiary chooses the option to deliver its own cable. This by exception to what is stated in Service Description 2030 and Service Description 2035 as in accordance to which Belgacom automatically delivers the associated number and type of Tie Cable for every Block ordered.
2. Except for the specific provision contained the present document, the other Annexes and in particular “Annex B2: Service Description 2030” and “Annex B3: Service Description 2035” remain fully applicable.
3. The present General Terms and Conditions shall prevail on any other contractual obligations in respect to the specific subject matter “Tie Cable delivered by Beneficiary”.
4. For the sake of clarity this present Service Description applies to connection to the Physical Colocation badge or escorted access as well to connection to the Distant Colocation.

3 Definition of service

5. This Service is provided in the framework of the services as indicated in the General Terms and Conditions for the provisioning of Raw Copper in the Local Loops.
6. When Beneficiary orders the dedicated equipment at Belgacom’s Local Exchange building prior to the request of ULL Raw Copper Services, Beneficiary shall indicate on the firm order form that the delivery of the associated Tie Cable will be the responsibility of the Beneficiary.
7. Beneficiary will provide on Requested Date of Delivery Belgacom with at least the exact length of cable on reel needed to execute the order. Place of delivery is determined by the LEX of installation.
8. Installation of the Tie Cable will only be done by the technicians of Belgacom or by the subcontractors of Belgacom.
9. For the sake of clarity the cable remains the property of Beneficiary and under its responsibility.
10. The demarcation point in case of Beneficiary delivered Tie cabling will be the Beneficiary dedicated Blocks on the MDF in case of Raw Copper. In case of tie cabling delivered by the Beneficiary, the area where the Demarcation Point is situated (MDF area in case of Raw Copper) at the Belgacom Local Exchange or Local Distribution Center is in principle accessible to the Beneficiary for maintenance and test purposes. Beneficiary will have to justify the necessity of the planned maintenance and/or tests.
11. Beneficiary will have to substantially indicate the purpose of this access (to be mentioned with the application for guided access).



12. The access will be always with a security escort, at the expenses of the Beneficiary, and pursuant the conditions for guided access as described in the framework of co-mingling (physical colocation with escort access).

4 Ordering Infrastructure

13. Except for the specific provisions stated in the present section 3, “Annex E: Planning and Operations Manual” remains fully applicable.

4.1 General

14. Orders are related to Beneficiary dedicated equipment at the Belgacom's LEX's. This equipment only consists in Beneficiary Horizontal Blocks. The ordered Beneficiary Blocks will be standard equipment (see “Annex C: Technical Specifications”). All installation is done by the technicians of Belgacom or by the subcontractors of Belgacom. Forecasts (if any) and Ordering are done for Beneficiary Horizontal Blocks, where for every Block ordered the associated number and type of Tie Cables will be delivered by Beneficiary.
15. When Beneficiary submits its firm order form, to order dedicated equipment at the Belgacom LEX for the pre-provisioning of Raw Copper, Beneficiary will indicate that he will provide the associated Tie Cable. Beneficiary will fill in the date and hour for delivery of the cable.
16. Firm orders shall be done through the use of the specific templates provided on the Belgacom secured website for LLU.
17. Templates will be considered as valid only when they are properly completed. In case data is missing or is not correct, the template will be rejected. In the latter case, Belgacom will indicate the reasons of rejection on the template. All firm orders will be submitted by registered mail to the SPOC of Belgacom for ULL.
18. For the sake of clarity, it is confirmed that for all matters related to the forecasting process will follow the guidelines as stated in “Annex E: Planning and Operations Manual”.

4.2 Prerequisites

19. As long as a Beneficiary does not have approved colocation facilities, no Beneficiary Horizontal Blocks orders can be submitted. A colocation facility is approved once the colocation Agreement has been signed and proof of payment of advance payment or 50% of the costs charged to the Beneficiary have been provided by Beneficiary.

4.3 Ordering procedure

20. The Beneficiary can order its blocks through a firm order. A firm order consists of the requested number of Beneficiary Horizontal Blocks, per type of Blocks (see order template available on the Belgacom secured website for LLU) and this for each LEX. Together with the firm order, the Beneficiary includes the date when he wants the Blocks and associated Tie Cabling to be ready.
21. In the situation where cable trays are present, Tie Cable has been delivered by Beneficiary and sufficient place is available on the MDF, the delay for a firm order will be equal to the delay as stated in “Annex E: Planning and Operations Manual”.
22. In all other cases, the Beneficiary will need to take into account the delays as stated in “Annex E: Planning and Operations Manual”.
23. Belgacom will confirm the receipt of every firm order. When the installation of the Blocks and Tie Cabling is complete, the OLO will receive documentation on the position of his blocks on the MDF and on the references of the positions on the blocks. This information is important to communicate together with each order for a specific Raw Copper loop.

5 Specific Conditions

24. When delivering the Tie Cable, Beneficiary has to fulfill the following specific conditions.
If Beneficiary has not fulfilled one or more conditions, Belgacom can neither guarantee to meet its own obligations, nor to respect the delays as set in the present document and other annexes.

25. For any additional work that explicitly or implicitly needs to be done by Belgacom because Beneficiary has not fulfilled one or more conditions, Belgacom reserves the right to bill the Beneficiary for the work executed by Belgacom.

5.1 Type of cable

26. Each telecom cable consists of a number of copper conductors grouped in quads; these quads can be arranged in bundles or in layers, depending on the type of cable.
Cable delivered by Beneficiary will have to comply with the technical requirements as set by Belgacom in “Appendix A: Technical Specifications”.

5.2 Identification of cable

- Following markings should be made in relief on the outer sheath of the cable:
 - Name of Beneficiary
 - The nominal number of pairs
 - The diameter of the conductors
 - The year of production
 - The name or sign of the supplier

E.g.: For a cable series 12 with 20 pairs, with conductors 0,5 mm, in 2001 made by supplier X the marking becomes: Beneficiary 12 050 5 -01 -X

- The marking should be repeated every 500mm.

5.3 Length of cable

- Depending on the LEX where the Tie Cable has to be installed, the length of cable will be different.
27. In "Appendix B: a list with the exact length that is needed per LEX can be found.
28. Note that this list only mentions the LEX's where colocation facilities have already been established and the exact length of Tie Cable is already known. For other LEX's, length will be provided by Belgacom as part of the quotation form.
- Beneficiary has to deliver to Belgacom at least the exact length of cable.
 - Length of cable may be cumulated. Beneficiary will deliver a separate reel per involved site, if any.
 - Beneficiary will deliver per order a separate reel with the requested length of the cable.

5.4 Cable delivered on reel

- Beneficiary will deliver the cable, reeled in an even way, on a reel. This reel will have to comply with the specifications as set in “Appendix A: Technical specifications”.
- The reel of the Beneficiary will be recognizable by a dedicated colour and the flange of the reels shall contain a label with:
 - Name Beneficiary
 - Name of contact person of Beneficiary
 - Telephone number where the contact person can be reached
 - The cable type
 - LEX name where the cable has to be installed
 - Order Reference Number
- The identifications should be easy to read and should not deteriorate under atmospheric circumstances.

5.5 Place where to deliver the cable

29. Depending on the LEX where the cable will be installed, the Beneficiary will have to deliver the cable on a predefined location. A list with the LEX's, where the colocation facilities have already been established, will indicate per LEX at which location the cable has to be delivered. See “Appendix B: List with places to deliver the cable”.

5.6 Appointment to deliver the cable

- As the locations, where the reel with cable has to be delivered, are not free accessible and not permanently manned, the Beneficiary has to make an appointment to deliver the cable.
- Beneficiary has to put on the firm order form his requested date and hour of delivery.

This date has to fall within the following timeframe:

- For the date, Beneficiary can set the day to deliver the cable:
 - * At the earliest: day of ordering + 2 Working Days
 - * At the latest: day of ordering + 4 Working Days
- For the hour, Beneficiary has to make his choice between:
 - * From 8.00 till 8.30
 - * From 8.30 till 9.00

* From 9.00 till 9.30

5.7 Receipt of goods

30. When Beneficiary delivers the reel with cable at the requested date of delivery, a Belgacom person will be present to take delivery of the goods. A receipt of goods form will be filled out. See template. Available on the Belgacom secured website for LLU.

5.8 Remove empty reel

- After Installation of the Tie Cable, Belgacom will bring the empty reel back to the place where Beneficiary has delivered the reel. Beneficiary will have to pick-up the empty reel at the date and hour which has been confirmed on the test & visit report.

This date has to fall within the following timeframe:

- For the date, Beneficiary can set the day to pick-up the empty reel:
 - * At the earliest: day of testing + 2 Working Days
 - * At the latest: day of testing + 4 Working Days
- For the hour, Beneficiary has to make his choice between:
 - * From 8.00 till 8.30
 - * From 8.30 till 9.00
 - * From 9.00 till 9.30

6 Prerequisite for the installation of Tie Cable delivered by Beneficiary

- Installation of the Tie Cable will be done by the technicians of Belgacom or by the subcontractors of Belgacom.
- Installation will be done within the timeframe, as set in “Annex E: Planning and Operations Manual”, only if all conditions linked to the delivery of the Tie Cable have been fulfilled.
- Whenever one of the conditions for the delivery of the Tie Cable has not been met or problems linked to the cable occur during the installation, Belgacom will inform Beneficiary SPOC. The delay due to these circumstances will be added to the timeframe as set in “Annex E: Planning and Operations Manual”.

7 Fault Reporting and Repair

31. Except for the specific provisions stated in the present section 6, “Annex E: Planning and Operations Manual” remains fully applicable.

32. In case Beneficiary considers it necessary during repair to perform certain tests, specific linked to the Tie Cable, it is the responsibility of the Beneficiary to give well-defined orders to Belgacom. Beneficiary will be billed for all work for which he has given the order and that has been executed by Belgacom.

8 Ownership and responsibilities

33. As mentioned in point 2, the cable remains the property of Beneficiary and under its responsibility.
34. For the sake of clarity, Beneficiary will be responsible for any damages caused by its cable to Belgacom or to any other third party.
35. For technical reasons, once the cable has been installed, Beneficiary will not be authorised to remove it, except if Beneficiary agrees to pay for the cost incurred by Belgacom to remove the cable.
36. Should the cable request technical intervention (tests in case of repair or replacement of cable), the work will exclusively be executed by Belgacom upon written request by the Beneficiary. The cost incurred by Belgacom for this intervention will be exclusively beared by Beneficiary.

9 Financial conditions

37. All charges and fees linked to the management and administrative work done by Belgacom, linked to the storage space and the installation, will be settled according to “Annex H: Price List”.
- 38.

Belgacom access to the Raw Copper Loop

At Local Distribution Centers

Existing single pair & Small Network Adaptations

Annex B 1.5 Service Description 2015

Created on: 16 February 2012

belgacom

together with





together
with



1 Table of contents

1	Table of contents.....	2
2	Scope	3
3	Definition	4
3.1	Product definition of Raw Copper Circuit	4
3.2	Product definition of Small Network Adaptations	5
3.3	Small Network Adaptations	6
3.4	Network Termination Point	7
3.5	Type of Loops offered by Belgacom	7
4	Connectivity to the Beneficiary Network	9
5	Colocation	10
6	Spectrum Management and equipment aspects	11
7	Boundary conditions and prerequisites	12
8	Ordering of Raw Copper	13
8.1	Standard provisioning rules	13
8.2	Non-standard provisioning rules	19
9	Wrongful repair requests.....	20

2 Scope

1. This Service Description deals with the definition of services, equipment and application requirements and properties of the Belgacom offer for renting Raw Copper Loops and related Small Network Adaptations as described under Section 2, and procedures for ordering of and fault reporting to Belgacom with respect to the services described herein on the Raw Copper Circuit.

3 Definition

3.1 Product definition of Raw Copper Circuit

2. Raw Copper Loop or Raw Copper Circuit means a pair of fully metallic continuous unequipped copper wires on the section between Belgacom's Main Distribution Frame at the Belgacom LDC and the a Network Termination Point at the User's site. The Raw Copper Loop or Raw Copper Circuit can be delivered on a Non-active Loop or an active Loop.

3. Beneficiary has the right to gain access to an end-to-end Raw Copper Loop at Belgacom LDC s, on the condition that the requested copper pair is unequipped. A pair is equipped when load coils or Active Equipment (coupling, repeaters, correctors, etc.) are present in the relevant circuit/s. Belgacom will make an equipped pair unequipped when possible. In case that the equipped pair cannot be made unequipped, this will be proved to the Beneficiary. Beneficiary will have access to the Raw Copper Loop at the Main Distribution Frame level on which the Raw Copper Loop is terminated. It is further required that, in the scope of this Service Description, the Raw Copper Loop is existing and can be used without the need of severe network modification works. The Small Network Adaptations performed by Belgacom are described in Section 2.2 and 2.3.

4. The access to the Raw Copper Circuit at the Belgacom network side will be realized on the Belgacom Main Distribution Frame (MDF) by using dedicated Blocks per Beneficiary. The access to the Raw Copper circuit at the User site will be at the Belgacom Network Termination Point (NTP).

5. The Demarcation Point will be
 - in case of Physical or Virtual Colocation: the point on the Tie Cable just before it is connected to the collocated equipment of the Beneficiary.
 - in case of Distant Colocation: the Connectors in a Cross Connection Cabinet in the immediate vicinity of the Belgacom Local building.

The demarcation point in case of Beneficiary delivered Tie cabling shall be the Beneficiary dedicated Blocks on the MDF in case of Raw Copper. In case of Tie cabling delivered by the Beneficiary, the Beneficiary has access to the area where the demarcation point is situated (MDF area in case of Raw Copper) at the Belgacom Local Exchange or Local Distribution Center for maintenance and test purposes. Beneficiary shall have to justify the necessity of the maintenance and/or tests planned. Beneficiary shall have to indicate the purpose of this access substantially (to be mentioned with the application for guided access). The access shall always be with a security escort, at the expense of the Beneficiary, and pursuant the conditions for guided access as described in the framework of co-mingling (physical colocation with escort access).

6. It is further required that in the scope of this Service Description, the Raw Copper Circuit is existing and can be provided without new construction of physical copper wires in the network. The construction of new Raw Copper Circuits is outside the scope of this Service Description.
7. Establishment of a Network Termination Point (where relevant) and cross connections in the local access network between Distribution Cable and the Feeder Cable (where relevant) are part of the provisioning and installation of the Raw Copper Circuit under this Service Description.

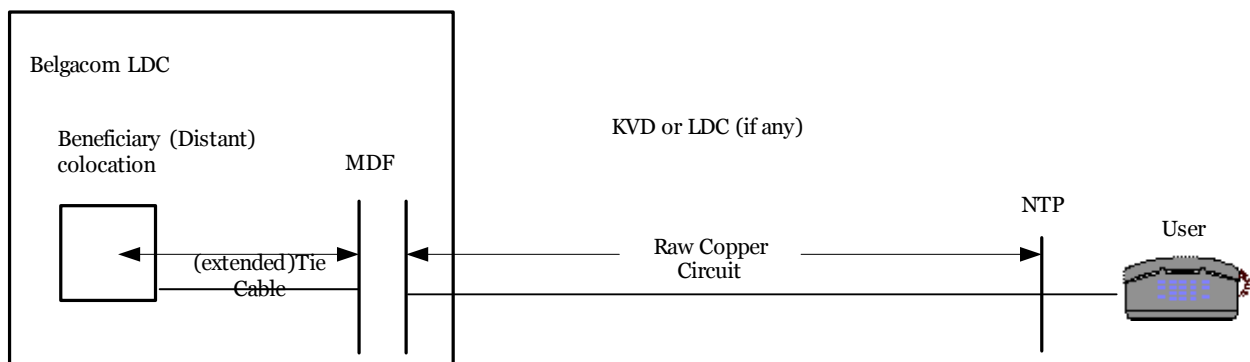

Fig. 1

3.2 Product definition of Small Network Adaptations

8. The Introduction Cable (also referred to as drop wire) is defined as the part of a Raw Copper Loop that connects the Distribution Cable to the User Network Termination Point.
9. In some cases, the pair of fully metallic continuous unequipped copper wires exists from the Belgacom Main Distribution Frame at the Belgacom LDC up to the Distribution Cable in the street in front of the User premises.

10. The present Service Description establishes the terms and conditions under which Belgacom will perform Small Network Adaptations by means of drop wire construction or drop wire intervention.

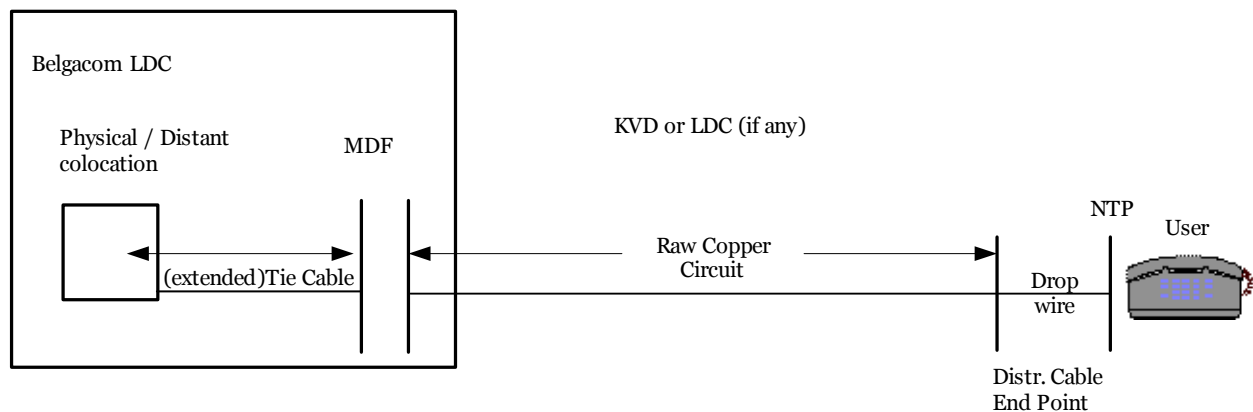

Fig. 2

3.3 Small Network Adaptations

11. In some cases, the pair of fully metallic continuous unequipped copper wires exists from the Belgacom Main Distribution Frame at the Belgacom LDC up to the Distribution Cable in the street in front of the User premises.
12. In case no Introduction Cable is available for the provisioning of a Raw Copper Loop, the following solutions will be applicable:
- Realization of a new introduction in the building of the Beneficiaries User
 - Renewal of the introduction in the building of the Beneficiaries User
 - Splicing additional pairs in the existing introduction splice of the building of the Beneficiaries User
 - Moving existing introduction from an existing Distribution Cable to another existing Distribution Cable.
13. These solutions will only be available upon specific request of the Beneficiary and providing that the Belgacom standard conditions for access are fulfilled. This requires that a free duct or an open trench is available on the private domain. If a free duct or an open trench is not available on the private domain, Belgacom can be asked to also perform this part of the work on condition that the Beneficiary agrees to pay the commercial price for that part of the work performed by Belgacom. This price will be determined on a case by case basis.

14. Belgacom will only perform the Small Network Adaptations if the splicing is done in front of the premises of that specific User. Belgacom will provide an Introduction Cable with a standard length of 20 meters to provide connection between the Distribution cable and the Network Termination Point. In case an introduction with a length of more than 20 meters has to be provided, Belgacom will charge the Beneficiary the relevant price for the extra work.
15. In case no more free pairs are available in the Distribution Cable or the Feeder Cable, the request for Raw Copper Loops will be rejected. The construction or trenching of new distribution cabling, new street cabinets or new feeder cabling is outside the scope of the present offer.

3.4 Network Termination Point.

16. If no Network Termination Point is present, such Network Termination Point will be installed by Belgacom. This is automatically the case for Small Network Adaptations. New internal cabling must always, except when specified otherwise, be provided by Belgacom, or under his responsibility, if existing internal cabling is insufficient in capacity of free pairs or of poor quality.
17. The attention is drawn to the fact that Belgacom reserves the right to propose on a non-discriminatory basis various scenarios to provide an adequate answer to the situation in which a cable (sometimes referred to as internal cabling) is placed between the Network Termination Point and the Introduction Cable. Such an answer is to be developed on a case-by-case basis and would need to take into account, in particular and where relevant, the presence of an introduction box, the way of introducing the Raw Copper Loop in the building of the User, the specific status of the cabling, the nature of the building and/or the work to be accomplished to offer the Service.
18. The current way of working will be evaluated after the necessary experience has been obtained by all Parties in the installation of Raw Copper Loops and Circuits. Belgacom will re-evaluate the offer and reserves the right to propose the necessary modifications on this item.

3.5 Type of Loops offered by Belgacom

19. The following types of Raw Copper Loops are offered under the present Reference Offer for ULL (for technical details concerning the nature of the signals to be used on each type of Raw Copper Loops, see the Technical Specifications Document that can be found in Annex C):
 - **Raw Copper Loops of Type 1:** Basic Raw Copper Loop only to be used for the transmission of signals (including and starting from direct current) within the voice frequency band, being PSTN or Raw Copper Loop only to be used for the transmission of signals for which the binary rate is smaller or equal to 64 kbit/s or for the transmission of signals using ISDN basic access line code.

- **Raw Copper Loops of Type 2:** Raw Copper Loop to be used According to the rules of the technical specifications document (annex c). The Beneficiary can also use the Raw Copper Loop like Type 1, obviously.
20. In ordering, Beneficiary indicates the type of loop per qualification as described above. Belgacom will handle requests for Type 1 as PSTN and Type 2 loops will by default be treated as ADSL over PSTN with respect to matters of repair and the quality of service related to the repair requests. Belgacom will not bear any liability relating to the absence of qualification of the loop when the loop qualification (e.g. Type 1 PSTN, Type 1 ISDN, Type 2 ADSL, Type 2 SDSL) was not included with the repair request. If this qualification is different from the default documented qualification as above, Beneficiary is invited to specify the service residing on the loop if this is necessary to facilitate the repair process.
21. The use of a totally unbundled Loop is free, provided that the Beneficiary complies with the “Spectrum Management” rules. The “Spectrum Management” rules regarding Unbundled Loops are described in Annex C to the present Reference Offer. Rules for “Spectrum Management” can be proposed by the Task Group Spectrum Management or BIPT can be added to the present Reference Offer. Depending on the type of equipment that is directly connected to the unbundled Local Loop, different rules for the bringing into service and for the service level can be applicable.

4 Connectivity to the Beneficiary Network

22. At the Belgacom LDC, the copper wires are terminated on the Main Distribution Frame. Beneficiary's access to the copper wire pairs will be established by connecting Tie Cables from the Main Distribution Frame to the colocation area, as described in the relevant LDC colocation documents.
23. The installation and maintenance of the (Extended) Tie Cable and the provisioning and maintenance of the Blocks will be made by Belgacom, as presented in Service Description 2045.

5 Colocation

24. For the provision of Colocation Services reference is made to the Colocation Agreement. Subscriptions to this agreement is a pre-requisite to install equipment in a Belgacom building. For the sake of clarity, Colocation Services can only be used to benefit from specific Belgacom Services requiring colocation.

6 Spectrum Management and equipment aspects

25. “Annex C: Technical Specifications Document” to the contract, contains requirements related to Spectrum Management and equipment connected to the Raw Copper pair.

7 Boundary conditions and prerequisites

26. The Beneficiary is only allowed to use the indicated type of Raw Copper Loop for the purpose described in Section 2.5. In any case of changes by the Beneficiary of the equipment/technology used, the Beneficiary will inform Belgacom of this fact in order to avoid service degradation in the Belgacom Network for other Users.
27. At all times, the coexistence needs to be ensured between the services provided by the Beneficiary through the use of the Raw Copper Loops and the services provided by Belgacom or another Beneficiary on the Belgacom Network. In particular, Belgacom will be entitled to take a number of measures to protect its network integrity taking into account the need to ensure the coexistence of the different services mentioned above.
28. All equipment used by the Beneficiary will at least comply with the R&TTE Directive.
29. It is noted that Belgacom will not undertake customer care handling of Users of the Beneficiary. If Belgacom receives requests from Users of the Beneficiary due to the inadequate handling of such requests by the Beneficiary, Belgacom will not deal with them.
30. In case there is a change of Raw Copper Loop type, the Beneficiary will address a request for a deactivation and an installation to Belgacom, in order to obtain the requested modification.
31. If equipment or network components, that are operated by Beneficiary for its own use and that are connected to Belgacom's public telecommunications network, cause disturbances in Belgacom's network, Beneficiary shall be required to disconnect the User connection without any delay.
32. Belgacom shall use all reasonable endeavours to correct any trouble affecting the quality of service Belgacom is providing to its own Users. In this respect, Belgacom is entitled to disconnect Beneficiary's connection to Belgacom's access network, on the basis of User complaints, reports from the operational services of Belgacom, etc., and provided that Belgacom can demonstrate that Beneficiary's systems cause service degradation or disruption of the services offered by Belgacom in the network.

8 Ordering of Raw Copper

33. Belgacom shall deliver access to the Raw Copper according to Beneficiary's orders transmitted to Belgacom. The general terms and conditions for delivering Raw Copper Loops are defined in "Annex E: Planning and Operations manual".
34. The full details of the provisioning process can also be found in "Annex E: Planning and Operations manual".

8.1 Standard provisioning rules

Beneficiary orders and ends a Raw Copper Service by means of the electronic order form. See Annex E "Planning and Operations Manual" for more details.

The Beneficiary can obtain the following Standard Raw Copper Services:

<i>Service in respect of Raw Copper</i>	<i>Description</i>	<i>Fee</i>
<i>1. Inquiry</i>	<i>Examination of whether a Raw Copper (Sub-)Loop can be provided end to end</i>	<i>Inquiry fee</i>
<i>2. Request for a Raw Copper (Sub-)Loop</i>	<i>Physical cross connection of the Raw Copper (Sub-)Loop to the Beneficiary's Tie Cable at the Main Distribution Frame of the Belgacom Local Exchange, as well as - if necessary - related work at the User's site</i>	<i>Activation fee</i>
<i>3. Cancellation of a Request for a Raw Copper (Sub-)Loop</i>	<i>Orders that have been placed by the Beneficiary but that are cancelled prior to implementation</i>	<i>Cancellation fee</i>
<i>4. Installation of an NTP if necessary</i>	<i>Belgacom installs a Network Termination Point at the User's premises side</i>	<i>Telecom installation fee ,invoiced on top of the activation fee</i>
<i>5. Deactivation of a Raw Copper (Sub-)Loop</i>	<i>Belgacom disconnects the related copper wires from the Beneficiary's dedicated</i>	<i>Deactivation fee</i>

<i>Service in respect of Raw Copper</i>	<i>Description</i>	<i>Fee</i>
	<i>Blocks</i>	
6. <i>Change date</i>	<i>The Beneficiary requests a change in due date for the provisioning of a Raw Copper loop</i>	<i>Change date fee</i>
7. <i>Transfer¹</i>	<i>Transfer of a Raw Copper (Sub-)Loop from Beneficiary 1 to Beneficiary 2</i>	<i>Physical migration fee, billed to Beneficiary 2</i>

Further comments:

(1) Inquiry

The purpose of an inquiry is to investigate the availability of an end-to-end Raw Copper Loop at a particular User site. For Type 2 loops, Belgacom will additionally perform a pair selection test to verify that the service can coexist with the surrounding pairs. An inquiry gives only the status of a Raw Copper Loop in relation to a specific User at one specific moment in time. Belgacom guarantees the accuracy of the information provided at the moment of the inquiry, without prejudice to any subsequent change in the technical situation.

(2) Request for a Raw Copper Loop

There are three possible situations, depending on the impact of the provision of Raw Copper (Sub-) Loops to the Beneficiary on the contractual relation between the User and Belgacom:

- The Raw Copper Loop Request concerns a Non-active Loop and therefore does not affect the existing relation between Belgacom and the User. This is only possible if there is a (Non)-active Loop available at the User's premises.
- The Raw Copper Loop Request concerns an Active Loop and therefore affects the existing relation between Belgacom and the User. This Request is also called a **Migration**.
- The Raw Copper (Sub)-loop Request implies a small network adaptation (see 2.3).

Inquiry

¹ See chapter 9: Migrations

In case the Beneficiary places a firm order for a Type 1 Raw Copper Loop as defined above, Belgacom will carry out an inquiry to determine whether a Non-active Loop exists between the User and the Belgacom LDC (as indicated by the Beneficiary). For the firm order of a Type 2 Raw Copper Loop as defined above, Belgacom will perform additionally a pair selection test to verify whether the service, as indicated by the Beneficiary, can coexist with the surrounding pairs.

Rejection for technical reasons

In case the order cannot be implemented because of technical reasons, which has to be detailed and proved to the Beneficiary, the Beneficiary's Request will be rejected. In this case, the Beneficiary will be billed for the work done by Belgacom on validation of that order. If the firm order can be implemented, Belgacom will proceed with the implementation of that order according to the applicable process, which can be obtained at the Belgacom contact point mentioned above.

NTP installation

Belgacom will install an NTP, as termination point on the Raw Copper Loop, if such an NTP does not exist (see 2.4).

In case of Migration

In the case of a Migration, the user has the right to cancel an existing service that is currently made available to the User by Belgacom according to his contractual relationship with Belgacom. The services that can be terminated are the following: a single line PSTN service, a single line ISDN service or any other service (including a leased line). In such a case, Belgacom will ensure that the cancellation of the existing Belgacom Services and the provisions of the Raw Copper will take place on the same day, not exceeding 4 hours. In case the Raw Copper (Sub-)Loop between the User and Belgacom exists less than one year, the User may be billed by Belgacom an extra charge for the Migration of that specific loop.

In case of Number Portability

In case of a request for Migration, the Beneficiary has also the possibility to request Belgacom to provide the porting of the User numbers in case the User formerly had a single line PSTN or ISDN service with Belgacom. In this case, there is an interaction with the Number Portability (NP) process, for which the Beneficiary will need to comply with the relevant procedures. The Beneficiary needs to introduce first an order for NP and later one for Raw Copper. In ordering Raw Copper, the Beneficiary Requested Date that is always provided by Beneficiary, need to match the requested execution date for Number Portability. Beneficiary will respect the rules for a Migration of Raw Copper and the procedures for number portability. In case there is a number



portability request, the Beneficiary will indicate the numbers currently used by the User, which have to be ported to the Beneficiary on the Raw Copper Loop concerned.

In case NP is involved in the Migration, the Beneficiary will indicate that on the request form. If the User has a single line PSTN service with Belgacom, the Beneficiary is required to use the existing NTP that will not be removed by Belgacom. If the User has a single line ISDN service with Belgacom, the existing NTP will be removed by Belgacom and replaced with a TF2001 or other device. These rules are not applicable in case the NTP is a cross-connectable distribution box where multiple pairs are connectable for that User.

In case of Small Network Adaptations

1. Beneficiary has the possibility to indicate 'SNA not allowed' when ordering. If 'SNA not allowed' is flagged when ordering, Belgacom will send a reject of the order should the need for a SNA be established at any point in the provisioning phase.

2. In case the order is not flagged 'SNA not allowed', the process is as follows:

1. If a Small Network Adaptation need is detected during the order validation.

Belgacom will notify this into the XML VALIDATE message by communication in the remark type SmallNetworkAdaptations the word "NEEDED".

2. If a SNA need is detected during provisioning.

Belgacom will create a HOLD message where a new appointment date will be proposed and with in the remark type SmallNetworkAdaptations the word "NEEDED".

In both cases, the Beneficiary can then contact its End User for further negotiations.

(3) Cancellation of a Request for a Raw Copper Loop

The Beneficiary has the right to cancel an order that the Beneficiary has submitted to Belgacom for the implementation of a Raw Copper Loop. However, Belgacom will bill the Beneficiary for the work done in the process.

(4) Installation of an NTP if necessary

The circumstances under which an NTP is to be installed by Belgacom are described in point 2.4.

(5) Deactivation of a Raw Copper Loop

The Beneficiary can request the Deactivation of the Raw Copper Loop at a particular User site.

(6) Changed Use of a Raw Copper Loop

When the Beneficiary intends to use the Raw Copper Loop for other purposes than intended at the time of the first order, the Beneficiary will communicate the change of types to Belgacom (from Type 1 to Type 2 or vice versa). Belgacom then can take the necessary measurements for the changed use of that Raw Copper Loop. In addition, Belgacom reserves the right to reject the request of changed use for technical reasons in case the Raw Copper Loop cannot be provisioned in accordance with the request for changed use of the Beneficiary.

(7) Change Date

The Beneficiary will indicate on the order form the date at which the Beneficiary wishes Belgacom to provide the Raw Copper Loop (referred to as "Requested Installation Date" or "RID"). The Beneficiary has the right to change that date. In the latter case, the Beneficiary will be billed a Change Date fee.

(8) Transfer

When there is a transfer from Raw Copper Loops from Beneficiary 1 to Beneficiary 2, it is presumed that two Beneficiaries, according to agreement with the User, handle the removal of the User's services and coordinate the hand over of the Raw Copper.

It is acknowledged that Belgacom will transfer the Raw Copper Loop from Beneficiary 1 to Beneficiary 2 upon request of Beneficiary 2 solely. Belgacom will terminate the contract for that specific Raw Copper Loop by informing Beneficiary 1 of the request from Beneficiary 2, without revealing the identity of Beneficiary 2.

Belgacom handles the request of the Beneficiary 2, taking over the Raw Copper. Belgacom does not in any case handle complaints between Beneficiary 1 and Beneficiary 2.

The above services (listed under (1) to (8)) are settled according to the prices indicated in Annex H. For the installation fee, different price setting can apply to different types of Raw Copper Loops and different types of installations based on the work performed by Belgacom after approval by BIPT.

8.2 Non-standard provisioning rules

Belgacom will reject a Request for Raw Copper Loop, in particular:

- if no Non-active Loops are available (in case of a Request for a Non-active Loop); without prejudice of the right of the Beneficiary to request in that case a small network adaptation by Belgacom, according to the conditions as set out in Section 2
- if no Migration is possible due to technical constraints which must be detailed and proved to the Beneficiary in the implementation of the existing User connection;
- if the requested service is incompatible with the applicable pair selection rules as defined in annex C: Technical Specifications document;
- if no positions and/or pairs are available on the Beneficiary Blocks or Tie Cables in case of Physical colocation, or if no positions and/or pairs are available on the Beneficiary Blocks and Connectors or Extended Tie Cables in case of Distant colocation.

In case a Migration cannot be executed, the Beneficiary Request will be rejected. However, in that case the Beneficiary has the possibility to send to Belgacom a Non-active Loop Request. In the event that the latter Request can also not be executed, this Request will also be rejected.

9 Wrongful repair requests

Belgacom's fault repair of the Raw Copper between the Main Distribution Frame at the Belgacom LDC and the User NTP is included in the periodic payment for the Raw Copper Loop. The procedures for that fault reporting are described in "Annex E: Planning and Operations manual".

In case of a repair request where the fault was not caused by Belgacom and Belgacom has performed work for that repair request, Belgacom reserves the right to bill the Beneficiary for the work done by Belgacom in light of that specific request according to "Annex H: Price list". It is noted that Belgacom in a first phase will not automatically charge the Beneficiary for wrongful repair requests.

Belgacom access to the Raw Copper Loop

Connection to the collocation

Local Distribution Center (LDC)

Annex B 1.6 Service Description 2045

Created on: 16 February 2012

belgacom

together with





together
with



1 Table of contents

1	Table of contents.....	2
2	Scope	3
3	Definition of the service	4
4	Order increments	6

2 Scope

1. This Service Description deals with the definition of the service, equipment and application requirements for the connection of the Raw Copper Loops to the colocation of the Beneficiary.
2. Colocation is a prerequisite for the implementation of this Service Description. The installation and maintenance of colocation will be made by Belgacom.

3 Definition of the service

3. The following cases of Belgacom colocation exist:

- (1) LDC Building or container colocation¹
- (2) LDC cabinet colocation or LDC Cross connection cabinet colocation²
- (3) LDC vicinity colocation: Beneficiary will bring the cabling up to the LDC³

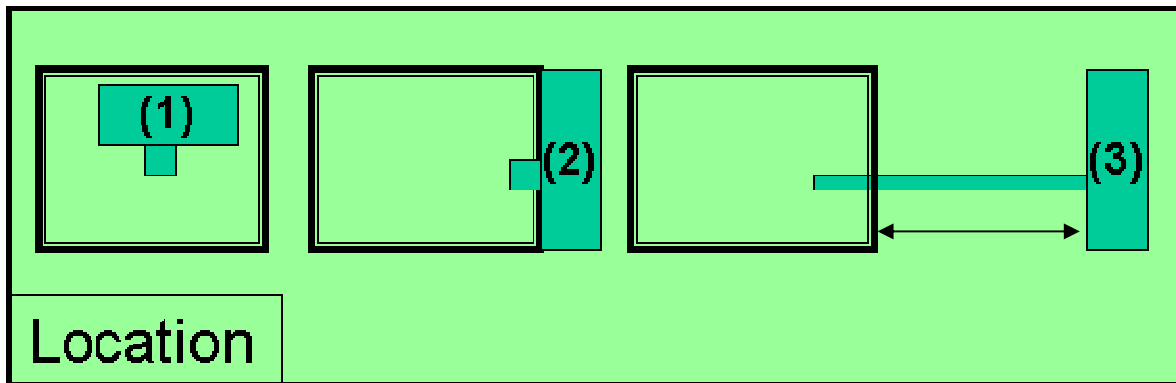

Fig. 1: Cases of Belgacom colocation

¹ Applicable for colocation case 2.2.1 and 2.2.2 in Service Description 'Colocation at the LDC Level'

² Applicable for colocation case 2.2.3 in Service Description 'Colocation at the LDC Level'

³ Applicable for colocation case 2.2.4 in Service Description 'Colocation at the LDC Level'

frame. Beneficiary's access to
 tion Frame of the Belgacom

tion to a dedicated Beneficiary

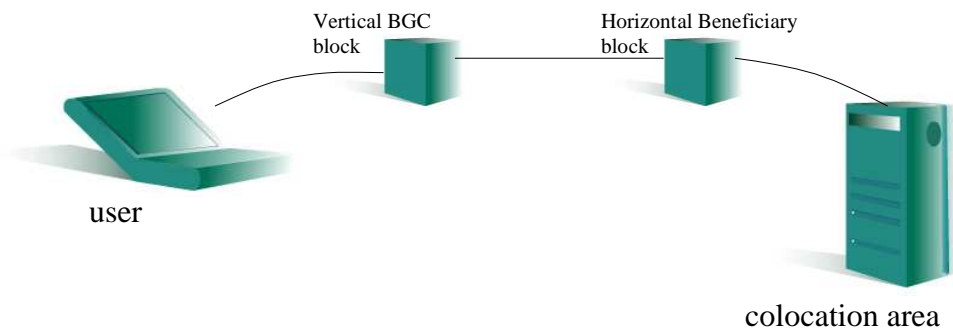

Fig. 2: Connection to the colocation

6. Beneficiary will order the Tie Cables and connection blocks at Belgacom's building prior to the request of Raw Copper Loops. This ordering process is described in "Annex E: Planning and Operations manual".
7. If at a certain moment, no more free wires are available in the Tie Cables or no more free space is available on blocks, the specific Raw Copper Loop requests issued by the Beneficiary will be rejected, since provisioning of that Raw Copper Loop cannot be implemented.

4 Order increments

Standard default order:

8. The default standard unit that Beneficiary can order for the provisioning between blocks on the MDF and the colocation area are:
 - 48 connections in case of LDC building or container colocation for connection of Type 2 loop: the block on the MDF will be a 1x48 pair block and the Tie Cabling 2x24 pair shielded cable
 - 48 connections in case of LDC Cabinet or LDC Cross Connection Cabinet colocation for connection to Type 2 loop: the block on the MDF will be a 1x48 pair blocks, the Tie Cabling 2x24 pair shielded cables, inside the Cabinet or Cross Connection cabinet, the Tie Cabling will be terminated on LSA blocks
 - 48 connections in case where Beneficiary brings cabling up to the LDC for Type 2 loop: the blocks on the MDF will be 1x48 blocks

Belgacom access to the Raw Copper Loop

Connection to the collocation

Street Cabinet (KVD)

Annex B 1.7 Service Description 2050

Created on: 16 February 2012

belgacom

together with





together
with



1 Table of contents

1	Table of contents.....	2
2	Scope	3
3	Definition of the service	4
4	Ordering	5

2 Scope

1. This document deals with the definition of the service, equipment and application requirements for the connection of the Raw Copper Loops to the colocation of the Beneficiary.

3 Definition of the service

2. Considering the complexity of the connection at the level of the street cabinet, whereby different types of KVD's, different technical situations and different surrounding grounds exist, it is impossible at this time to standardize a connectivity description at this level. Therefore the connection to the KVD will be handled case by case.
3. Belgacom will investigate and handle only elements that are property of Belgacom and reside on the property of Belgacom. Special permissions for works or performance of works at surrounding grounds will be at the charge and coordination of the Beneficiary.

4 Ordering

4. The Beneficiary will communicate an order by fax or e-mail to his respective account manager. The order form will include the KVD number and requested number of users, with a minimum of 24 users.
5. Based on this order, a study will be done. The results of this study, that includes the technical solution (in case there is one) and an estimation of costs, this will be communicated to the Beneficiary. Every study will be billed related to the man days, resources and transports that were needed.
6. After the study has been performed, Beneficiary can decide whether to continue with a fix order. The Beneficiary confirms to continue the order to the point of contact. Every order executed will be billed based on costs made in that case.
7. Extensions of connectivity at the same KVD, another Beneficiary requesting connection at that KVD or any change of prior installed equipment or prior determined positions will be subject to a full new study.

Belgacom access to the Raw Copper Loop

Multiple Pairs and Multiple Single Pair Orders

Annex B 1.8 SERVICE DESCRIPTION 2011

Created on: 16 February 2012

belgacom

together with





together
with



1 Table of contents

1	Table of contents.....	2
2	Scope	3
3	Ordering multiple pairs for one service at the same address	3
3.1	Definition	3
3.2	Ordering.....	3
3.3	Quality of the loop	4
3.4	Network Termination Point	4
3.5	Numbering	4
3.6	Small Network Adaptations	4
3.7	Repair	4
3.8	Service Level Agreement.....	5
3.9	Upgrade from more single pairs ordered before 01-01-2003 to multiple pairs.....	5
4	Ordering single pair orders submitted for the same date at the same address	5
4.1	Definition	5
4.2	Ordering.....	5
4.3	Service Level Agreement.....	6

Multiple Pairs and Multiple Single Pair

2 Scope

1. This document is valid for BRUO, Raw Copper type 2. All terms and conditions described in this offer will be applicable for the services described below, unless if stated otherwise.

3 Ordering multiple pairs for one service at the same address

3.1 Definition

2. When speaking of multiple pairs for one service, it is understood that this is the ordering of more than 1 pair of the same LLU product and product type at the same user address for the same Beneficiary to deliver a single service. Multiple pairs will be limited up to 4 pairs maximum. This kind of combined ordering makes that all services, like repair, and related conditions will be applicable for the group of pairs.

3.2 Ordering

3. Orders for Multiple Pairs for one service will be submitted by one order, using the default XML order form as described in Annex E1: Planning and Operations for Raw Copper, including the specific product name:
 - Raw Copper 2 pairs
 - Raw Copper 3 pairs
 - Raw Copper 4 pairs
4. Singularities of multiple pair orders, in addition to order singularities as described in Annex E1: Planning and Operations for Raw Copper:
 - The order for 2, 3 or 4 pairs will be done in the same order form only.
 - The pairs will have the same length
 - The pairs will be provisioned in the same quad if requested and if possible. In any case the order process will continue.
 - The order is by default subject of an extended inquiry procedure. The validation will include whether it is possible to install the service.
 - Small network adaptations is an option that needs to be explicitly included in the order form.
 - In case the required numbers of pairs cannot be found, the order will be stopped. Any change in the initial order (and product name) is subject to a new request to be submitted by the Beneficiary.

3.3 Quality of the loop

4. The quality of the loop will be the same as Raw Copper Type 2, every pair will be selected and assigned upon validation. Rules for pair selection will follow the technical specifications as described in Annex C: Technical Specifications of this offer.

3.4 Network Termination Point

5. Multiple pairs will use the same NTP as single pairs, this means 1 per pair.

3.5 Numbering

7. A group of multiple pairs, included in the same order, will be referred to by one unique reference. This unique reference number is provided upon provisioning to the Beneficiary.

3.6 Small Network Adaptations

8. Small network adaptations are works that will only be performed in case no Introduction Cable or an insufficient number of pairs for the requested service is available for the provisioning of one or more of the Raw Copper loops at the Beneficiaries user address.
9. Small Network Adaptations will be limited to:
 - Realization of a new introduction in the building of the Beneficiaries User
 - Renewal of the introduction in the building of the Beneficiaries User
 - Splicing additional pairs in the existing introduction splice of the building of the Beneficiaries User
 - Moving an existing introduction from an existing Distribution Cable to another Distribution Cable

3.7 Repair

10. Multiple Pairs

will be identified with one unique reference per multiple pair product. In case of service interruption or degradation due to Raw Copper, The Beneficiary will communicate the unique circuit id for the multiple pair product concerned.

3.8 Service Level Agreement

11. The Service Level Agreement defined in BRUO will be applicable for multiple pairs for one service.

3.9 Upgrade from more single pairs ordered before 01-01-2003 to multiple pairs

12. For more pairs ordered at the same address for the same User before multiple pair ordering was offered, these pairs can be converted to a multiple pair product on specific request. The Beneficiary will do its best effort to group its requests for upgrades.

4 Ordering single pair orders submitted for the same date at the same address

4.1 Definition

13. The ordering of multiple single pairs includes a combined execution on best effort bases. This pairs will be treated afterwards in the system as with the existing normal single pairs. Terms and conditions will be the same a single pairs described in this offer.
14. Repair will be notified to Belgacom pair per pair, taking into account the repair conditions as in Annex E1 Planning and Operations Manual.
15. The submission of two or more orders for the same LLU Product at the same address to be implemented at the same date will combine the simultaneous execution at LEX, LDC or KVD level on a best effort basis. Every order is to be treated as a separate order with a separate follow up, some might be accepted, some rejected, depending on availability and qualification.

4.2 Ordering

16. Multiple single pair orders should all be for the same product and product type.
At any moment during or after the installation, both loops will be handled and referred to separately.

4.3 Service Level Agreement

17. The Service Level Agreement defined in BRUO will be applicable for multiple single pair orders.

Belgacom Access to the Shared Pair Service

Annex B 2.1 Service Description 3010

Created on: 16 February 2012

belgacom

together with





together
with



1 Table of contents

1	Table of contents.....	2
2	Scope	3
3	Definition	3
3.1	Product definition of Shared Pair Service	3
3.2	Network Termination Point	4
3.3	Schematically	5
3.4	Service offered by Belgacom	6
4	Connectivity to the Beneficiary Network	6
5	Colocation	6
6	Spectrum management and equipment aspects	7
7	Boundary conditions and prerequisites	7
8	Ordering of Shared Pair.....	8
8.1	Standard provisioning rules	8
8.2	Termination of the voice subscription with Shared Pair	10
8.3	Non-standard provisioning rules	11
9	Wrongful repair requests.....	12

2 Scope

1. This Service Description deals with the definitions of services, equipment and application requirements and properties of the Belgacom Offer for Shared Pair Service as described under section 2.4; and the procedures for ordering of and fault reporting to Belgacom with respect to the Service described herein.

3 Definition

3.1 Product definition of Shared Pair Service

2. A Raw Copper Loop is a pair of fully metallic copper wires on the section between Belgacom's Main Distribution Frame at the Belgacom Local Exchange building and the User's site connected on a Network Termination Point.
3. The Shared Pair Service is the service by which Belgacom provides to an Beneficiary an access to an User by means of a part of the frequency of a Raw Copper Loop, whereby the entire frequency of the loop concerned is shared by Belgacom and the Beneficiary as follows:
 - Belgacom provides PSTN or ISDN BA services to the User (for which a Full Subscription Fee is paid for by the User concerned) on the voice frequency part (also referred to in the present document as the low bandwidth) of that Raw Copper Loop
 - Beneficiary provides data services to the same User based on ADSL technology on the non-voice frequency part (also referred to in the present document as the high bandwidth) of that same Raw Copper Loop
4. The Shared Pair Service requires that the User maintains his single line PSTN or ISDN BA Belgacom service for which a Subscription Fee is paid for by the User concerned. "Annex E: Planning and Operations Manual", describes the procedures that are applicable in case of modifications or cancellations requested by the User of the single line Belgacom PSTN or ISDN BA Service. Any modification or a cancellation of the single line PSTN or ISDN BA Belgacom service requested by the User, will affect the access to or the price of the Shared Pair Service by the Beneficiary.
5. A Shared Pair Service can therefore only be offered on a single, non-loaded and active pair. No load coils or other active equipment can be present in the circuit.

In case load coils or other active equipment are present in the circuit, Belgacom will provide a process for proceeding with a new pair choice if technically feasible, where infeasible has to be justified to the Beneficiary. For these services by Belgacom, the Beneficiary will be charged the related extra fee that will be included in "Annex H": Pricing.

6. Beneficiary has the right to gain access to Shared Pair Service at the Main Distribution Frame level of the Local Exchange, where Belgacom will install and maintain the necessary equipment to split the high frequency that is delivered to Beneficiary and the low frequency used by Belgacom. For details and definitions of the high and the low bandwidth, reference is made to “Annex C: Technical Specifications Document”.
7. The access to the high bandwidth at the Belgacom network side will be realized on the Belgacom Main Distribution Frame (MDF) by using dedicated Blocks per Beneficiary. From there, a pair of physical wires will be connected to the splitter rack (Connection Cables) and brought back from the Splitter rack to Beneficiary dedicated blocks for the low frequency. From the Splitter rack, connections will be made to the collocation area of the Beneficiary by use of Tie Cables in case of Physical collocation and by use of Extended Tie Cables in case of Distant collocation.
8. At the Local Exchange or the Local Distribution Center, the Demarcation Point in case of Belgacom delivered Te Cabling will be
 - in case of Physical or Virtual Colocation: the point on the Tie Cable just before it is connected to the collocated equipment of the Beneficiary..
 - in case of Distant Colocation: the Connectors in a Cross Connection Cabinet in the immediate vicinity of the Belgacom Local building.
9. Notwithstanding what is mentioned above, the demarcation point in case of Beneficiary delivered Tie cabling will be the Splitter rack in case of Shared pair.
In case of tie cabling delivered by the Beneficiary, the area where the Demarcation Point is situated (area where the Splitter Rack is situated in case of Shared Pair) at the Belgacom Local Exchange or Local Distribution Center is in principle accessible to the Beneficiary for maintenance and test purposes. Beneficiary will have to justify the necessity of the planned maintenance and/or tests.
10. Beneficiary will have to substantially indicate the purpose of this access (to be mentioned with the application for guided access).
11. The access will be always with a security escort, at the expenses of the Beneficiary, and pursuant the conditions for guided access as described in the framework of co-mingling (physical collocation with escort access).

3.2 Network Termination Point

12. The access to the high bandwidth at the User site will be at the Belgacom Network Termination Point (NTP).
13. For single line PSTN Service, the Beneficiary will install the equipment on the Belgacom Network Termination Point at the User site.
For single line ISDN BA service, an intervention of a Belgacom technician on the User site will be required in case the User site does not have an AETHRA NT1-2ab as Belgacom Network Termination Point. At the time of installation, this intervention will relate to the fact that, in these cases, a Splitter will be installed by Belgacom between the Belgacom Network and the Network Termination Point at the User site.

3.3 Schematically

Belgacom Local Exchange

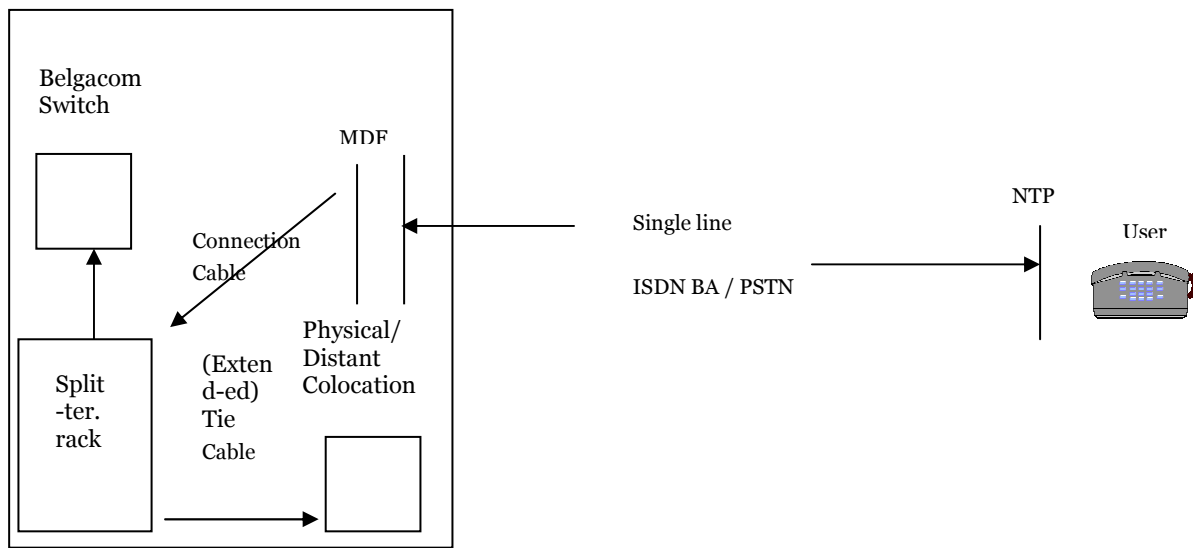

Fig. 1

For details on the Connection Cables and Tie Cables, reference is made to Service Description 3030 and 3035.

3.4 Service offered by Belgacom

14. The use of a Shared Pair is free, provided that the Beneficiary complies with the “Spectrum Management” rules described in the Annex C. Depending on the type of equipment that is directly connected to the unbundled Local Loop, different rules for the bringing into service and for the service level can be applicable. However, up until the Spectrum management rules have been fully described and implemented in the working group under supervision of the BIPT, and approved by the BIPT, the rules as set below will prevail.
 - A. SPP (Shared Pair Service over PSTN)
 - The high frequency band on the loop is to be used to connect ADSL equipment providing ADSL service capable of co-existing on the same pair as voice-band services (ADSL over PSTN). For technical details on the signals to be used, reference is made to “Annex C: Technical Specifications document”.
 - B. SPI (Shared Pair Service over ISDN)
 - The high frequency band on the loop is to be used to connect ADSL equipment providing ADSL service capable of co-existing on the same pair as ISDN Basic Access services (ADSL over ISDN). For technical details on the signals to be used, reference is made to “Annex C: Technical Specifications document”.

4 Connectivity to the Beneficiary Network

15. At the Belgacom Local Exchange building, the copper wires are terminated on the Main Distribution Frame. Beneficiary’s access to the copper wire pairs will be established by connecting Tie Cables from the Main Distribution Frame of the exchange to colocation area in case of physical colocation and by connecting Extended Tie Cables from the Main Distribution Frame of the exchange to the Cross Connection Cabinet in case of distant colocation.
16. The installation and maintenance of the (Extended) Tie Cable and the provisioning and maintenance of the Blocks will be made by Belgacom, as presented in Service Descriptions 3030 and 3035.

5 Colocation

17. For the provision of Colocation Services reference is made to the Colocation Agreement. Subscriptions to this agreement is a pre-requisite to install equipment in a Belgacom building. For the sake of clarity, Colocation Services can only be used to benefit from specific Belgacom Services requiring colocation.

6 Spectrum management and equipment aspects

18. “Annex C: Technical Specifications Document” to the contract, contains the requirements related to spectrum management and equipment connected for use of the shared pair.

7 Boundary conditions and prerequisites

19. The Beneficiary is only allowed to use the Shared Pair Service for the purpose described in Section 2.4.
20. All equipment used by the Beneficiary will comply with the R&TTE Directive.
21. It is noted that Belgacom will not undertake customer care handling of Users of the Beneficiary. If Belgacom receives requests from Users of the Beneficiary due to the inadequate handling of such requests by the Beneficiary, Belgacom will not deal with them.
22. In case there is a change in Shared Pair Service type, the Beneficiary will address a request for a deactivation and an installation to Belgacom, in order to obtain the requested modification.
23. If equipment or network components, that are operated by Beneficiary for its own use and that are connected to Belgacom’s public telecommunications network, cause disturbances in Belgacom’s network, Beneficiary shall be required to disconnect the User connection without any delay.
24. Belgacom shall use, in good faith, all reasonable endeavours to correct any trouble affecting the quality of service Belgacom is providing to its own Users. In this respect, Belgacom is entitled to disconnect Beneficiary’s connection to Belgacom’s access network, on the basis of User complaints, reports from the operational services of Belgacom, etc., and provided that Belgacom can demonstrate that Beneficiary’s systems cause service degradation or disruption of the services offered by Belgacom in the network.

8 Ordering of Shared Pair

25. Belgacom shall deliver access to the high bandwidth according to Beneficiary's orders transmitted to Belgacom. The general terms and conditions for delivering high bandwidth are defined in "Annex E: Planning and Operations manual".
26. The full details of the provisioning process can be found in "Annex E: Planning and Operations manual".

8.1 Standard provisioning rules

27. The Beneficiary can obtain the following standard Shared Pair Services:

Service	Contents	Fee
1.Inquiry	Examination of whether Shared Pair Service can be provided	Inquiry Fee (not to be paid if the inquiry is followed by a request)
2.Request for Shared Pair Service	Physical connection of the Shared Pair Service to the Beneficiary Network	Installation fee
3.Cancellation of Requests	Orders that have been placed by the Beneficiary but that are cancelled prior to implementation	Cancellation fee
4.Deactivation of Shared Pair Service	Belgacom disconnects the Shared Pair Service from the Beneficiary dedicated Blocks	Deactivation fee
5.Change Date	The Beneficiary requests a change in due date for the provisioning of the Shared Pair Service	Change date fee
6.NTP Intervention	If Belgacom needs to intervene at User site for the installation of a full-rate splitter	Telecom Installation fee, invoiced on top of the activation fee
7.Transfer	Transfer of a Shared Pair Service from Beneficiary 1 or Belgacom to Beneficiary 2	Is inferior to the installation fee (deactivation is at charge of Beneficiary 1)

Further comments:

28. On point 1

The purpose of an Inquiry is to investigate the availability of the Shared Pair Service at a particular User site. This inquiry consists of verifying whether an existing end to end single line PSTN or ISDN Belgacom service is available and of carrying out a pair selection test to verify that the Shared Pair Service, as indicated by the Beneficiary, can coexist with the surrounding pairs. An inquiry gives only the status of a of the User line at one specific moment in time. Belgacom guarantees the accuracy of the information provided at the moment of the inquiry, without prejudice to any subsequent change in the technical situation.

29. On point 2

The Beneficiary will indicate on his order form the date the Beneficiary wishes Belgacom to provision the Shared Pair Service.

30. When the Beneficiary places a firm order for the Shared Pair Service, Belgacom will also carry out a check whether the current existing single line ISDN or PSTN service is capable of supporting the high bandwidth signal requested by the Beneficiary. Belgacom will perform additionally a pair selection test to verify that the service, as ordered by the Beneficiary, can coexist with the surrounding pairs.

31. On new pair selection

In case the order can not be implemented on the ISDN BA or PSTN service due to the presence of load coils or other active equipment on the existing single pairs, Belgacom will inform the Beneficiary of this fact according to the process described in “Annex E: Planning and Operations manual”

When the Beneficiary does not confirm his Request at that time, the Request will be implemented if technically feasible and the Beneficiary will be billed for the other pair selection choice according to the different elements as set out in “Annex H2.1: Price List”

32. Belgacom will inform the Beneficiary in good faith, as soon as possible, of the modifications of the current ordering procedures by means of an Appendix to “Annex E: Planning and Operations Manual”.

33. In case the order cannot be implemented because of technical reasons (of which Belgacom has to publish a limitative list that can be adapted on a case by case basis afterwards), the Beneficiary's Request will be rejected. If the Request for Shared Pair Service can be implemented, Belgacom will proceed with the implementation of that firm order.

34. On point 3

The Beneficiary has the right to cancel an order that it has submitted to Belgacom for the implementation of a Shared Pair Service. However, Belgacom will bill the Beneficiary for the work done in the process.

35. On point 4

The Beneficiary can request the Deactivation of the Shared Pair Service at a particular User site

36. On point 5

The Beneficiary has the right to change the date it indicated at the time of transmitting the Request for the Shared Pair Service. In such a case, the Beneficiary will be billed a change date fee.

37. On point 7

When there is a transfer from Shared Pair Service from Beneficiary 1 to Beneficiary 2, it is presumed that two Beneficiaries, according to agreement with the User, handle the removal of the User's services and co-ordinate the hand over of the Shared Pair Service.

It is acknowledged that Belgacom will only transfer the Shared Pair Service from Beneficiary 1 to Beneficiary 2 upon request of Beneficiary 2 solely. Belgacom will terminate the contract for that specific Shared Pair Service by informing Beneficiary 1 of the request from Beneficiary 2, without revealing the identity of Beneficiary 2.

Belgacom handles the request of the Beneficiary 2, taking over the Shared Pair Service. Belgacom does not in any case handle complaints between Beneficiary 1 and Beneficiary 2.

38. The different services, as described above, are settled according to "Annex H2.1: Price list". For the installation fee, different price setting can apply to different types of installations based on the work done by Belgacom. Reference is made to Annex H2.1.

8.2 Termination of the voice subscription with Shared Pair

39. In case of a Shared Pair Service where both Belgacom and the Beneficiary provide services to an User, it can occur that the User cancels his voice subscription for that Shared Pair Loop. In that case, independent of the reason for termination of the voice subscription, Belgacom will ensure that the service on the high bandwidth remains into service. This is applicable in condition that positions on Belgacom Horizontal blocks that are not connected are available at the MDF.
40. Belgacom will inform the Beneficiary that the Shared Pair Service has been converted to a Raw Copper + Splitter, for which the Beneficiary will be charged the monthly rental fee for Raw Copper instead of Shared Pair. For repair the conditions of Raw Copper will apply. For the change to Raw Copper + splitter, no conversion fee is applicable. The Beneficiary has at that moment the possibility to ask for a conversion from its Shared Pair to a Raw Copper and will by this free up a dedicated Splitter Card. In this case, a conversion fee will be charged to the Beneficiary.

41. In case the Raw Copper + Splitter stays active and is not converted into Raw Copper, the terms and conditions applicable on repair and maintenance will be the terms and conditions applicable to Raw Copper Services as described in the Belgacom Reference Offer and the related documents.

A change to Raw Copper is only possible if Beneficiary concerned subscribed, next to Shared Pair, to a Raw Copper contract and if positions are free on the dedicated horizontal Beneficiary blocks under that raw copper contract.

42. If the Beneficiary decides to convert the Raw Copper + Splitter into Raw Copper, Beneficiary is notified of the fact that an interruption of its service during a limited timeframe (defined in hours) will take place in order to do the re-jumpering.
43. For the sake of clarity, this process can only take place pursuant the General Terms and Conditions and if the necessary infrastructure is in place to do the re-jumpering, without prejudice to other conditions that are currently being investigated from a process point of view.

8.3 Non-standard provisioning rules

44. In case the request for implementation of Shared Pair Service can not be executed, Beneficiary request will be rejected.
45. Belgacom will reject the requests if:
 -no single line PSTN or ISDN BA Belgacom Service is provided to the User concerned;-the requested service is incompatible with the Belgacom pair selection rules.

 -Belgacom will also reject requests if no positions and/or pairs are available on the Beneficiary Blocks, (Extended) Tie Cables and Connection Cables
46. Belgacom also will reject the requests if a new pair choice is reasonably and/or technically not possible over the existing infrastructure which must be detailed and proved to the Beneficiary.
47. Belgacom further reserves the right to reject requests for implementation of a Shared Pair Service for a Beneficiary based on wrong format data. The rejection list can be found in “Annex E: Planning and Operations manual”.

9 Wrongful repair requests

48. Belgacom's fault repair of Shared Pair Service between the Main Distribution Frame at the Local Exchange and the User NTP is included in the periodic payment for the Shared Pair. The procedures for that fault reporting are described in "Annex E: Planning and Operations manual".
 49. In case of a repair request where the fault was not caused by Belgacom and Belgacom has performed work for that repair request, Belgacom reserves the right to bill the Beneficiary for the work done by Belgacom in light of that specific request according to "Annex H2.1: Price list" It is noted that Belgacom in a first phase will not automatically charge the Beneficiary for wrongful repair requests.
-

Belgacom access to Shared Pair Service

Connection to the colocation area

Physical colocation

Annex B 2.2 Service Description 3030

Created on: 16 February 2012

belgacom

together with





together
with



1 Table of contents

1	Table of contents.....	2
2	Scope	3
3	Definition	3
4	Colocation	4
5	Provisioning of Blocks, Tie Cables and Splitters	5

2 Scope

1. This Service Description handles the definitions, equipment and application requirements for the connection of the Shared Pair Service to the Colocation area of Beneficiary, whereby Belgacom delivers all equipment mentioned below.

3 Definition

2. At the Belgacom Local Exchange, the copper wires are terminated in the Main Distribution Frames. Beneficiary's access to the Shared Pair Service will be established with Connection Cables and Tie Cables from the Main Distribution Frame of the Belgacom Local Exchange to Beneficiary's colocation area in that same Belgacom Local Exchange building.
3. Both the high and low frequency are brought to dedicated Beneficiary blocks. From a 48 pair block, a Connection Cable brings the high frequency and the low frequency to the Splitter Rack of Belgacom. The low frequency is brought back to another 48 pair Beneficiary block. A Cable is connected from this position to a Belgacom horizontal block that leads to the voice switch of Belgacom for providing the ISDN or PSTN Belgacom Service. Between the Splitter Rack and the colocation area, the transport of the signal done by use of Tie Cables.

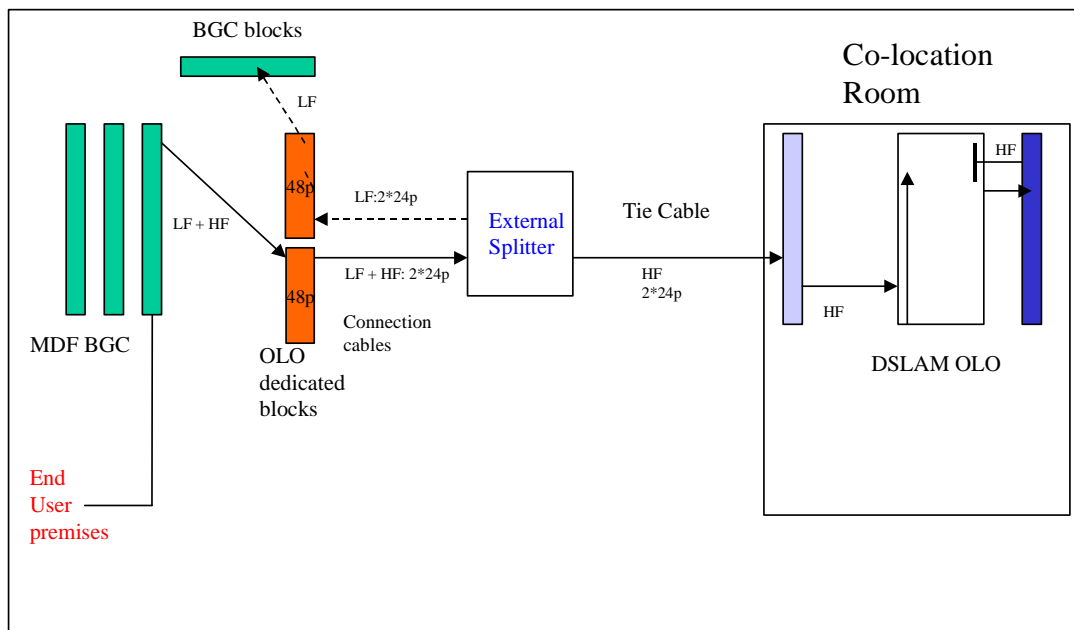

Fig. 1

4. Beneficiary will order the Tie Cables, Connection Cables, Blocks and Splitters at Belgacom's Local Exchange building prior to the request of Shared Pair Services for individual End Users. This ordering process is described in "Annex E: Planning and Operations manual".
5. If at a certain moment, no more free wires or positions on the blocks are available, the specific requests for individual End Users, issued by the Beneficiary, will be rejected, since provisioning of that Shared Pair Service cannot be implemented.
6. The connectivity at the LEX of Shared Pair is only possible if the voice service starts in the LEX. If the voice service resides at the LDC level it can be moved if possible to the LEX level in order to allow Shared Pair for that User at the LEX. The Beneficiary will pay the costs for this action.
7. The default standard unit that Beneficiary can order for the provisioning between blocks on the MDF and the Colocation area:
 - Blocks are 48 pair blocks; The minimum installation requires 2 blocks; 1 for cross connecting high and low bandwidth, 1 for connecting low bandwidth back to the Belgacom voice switch.
 - Cables will be per 24 pairs of shielded cable. The minimum installation requires 3 times 2*24 pairs; 2 times 2*24 pairs for the Connection Cable between Beneficiary blocks and Splitter rack, 1 time 2*24 pairs for the Tie Cable to the Colocation area of Beneficiary.
 - Splitters per 48. The Splitters have to be defined –per number of 24 Splitters- as being Splitters for PSTN lines or Splitters for ISDN lines.
8. Upon specific request of the Beneficiary, the incremental unit of ordering Tie Cables can be lowered to
 - 1 Block of 48 pairs
 - Cables will be per 24 pairs of shielded cable. The installation requires 3 times 24 pairs; 2 times 24 pairs for the Connection Cable between Beneficiary blocks and Splitter rack, 1 time 24 pairs for the Tie Cable to the Colocation area of Beneficiary.
 - Splitters per 24. The Splitters have to be defined as being Splitters for PSTN lines or Splitters for ISDN lines.
9. The request for this lower increment must be explicitly notified to Belgacom. The prices for this lower increment can be found in "Annex H: Price list".

4 Colocation

10. Physical Colocation is a prerequisite for the implementation of this Service Description. The installation and maintenance of colocation will be made by Belgacom, as presented in the "Belgacom Physical Colocation Agreement" attached to this Agreement.



together
with



5 Provisioning of Blocks, Tie Cables and Splitters

11. Reference is made to “Annex E: Planning and Operations manual”.

Product	Comments
1. 48 pair blocks for the provisioning of SPP/SPI loops.	Default ordering per increment of 2
2. 24 pair shielded cable for the provisioning of SPP/SPI loops	Default Ordering per increment of 6
3. 48 Splitters for SPP loops or SPI loops.	Default Ordering per increment of 1

Note: The above services are settled according to “Annex H2.2: Price list”.

Belgacom access to Shared Pair Service

Connection to the colocation area

Distant colocation

Annex B 2.3 Service Description 3035

Created on: 16 February 2012

belgacom

together with





together
with



1 Table of contents

1	Table of contents.....	2
2	Scope	3
3	Definition	3
4	Distant Colocation	5
5	Provisioning of blocks and Extended Tie Cables.....	5
6	Provisioning of connectors	6
7	Jumpering in the cross connection cabinet.	6

2 Scope

1. This service description handles the definitions, equipment and application requirements for the connection of the Shared Pair loops to the cross connection cabinet of Beneficiary, whereby Belgacom delivers the equipment mentioned below. The present service description is only applicable on the sites where Beneficiary has no physical collocation already at his disposal.

3 Definition

2. At the Belgacom Local Exchange, the copper wires are terminated in the Main Distribution Frames. Beneficiary's access to the Shared Pair Service will be established with Connection Cables and Extended Tie Cables from the Main Distribution Frame of the Belgacom Local Exchange to Beneficiary's cross connection cabinet.
3. Both the high and low frequency are brought to dedicated Beneficiary blocks. From a 48 pair block, a Connection Cable brings the high frequency and the low frequency to the Splitter Rack of Belgacom. The low frequency is brought back to another 48 pair Beneficiary block. A Cable is connected from this position to a Belgacom horizontal block that leads to the voice switch of Belgacom for providing the ISDN or PSTN Belgacom Service. Between the Splitter Rack and the Cross connection cabinet, the transport of the signal done by use of Extended Tie Cables.

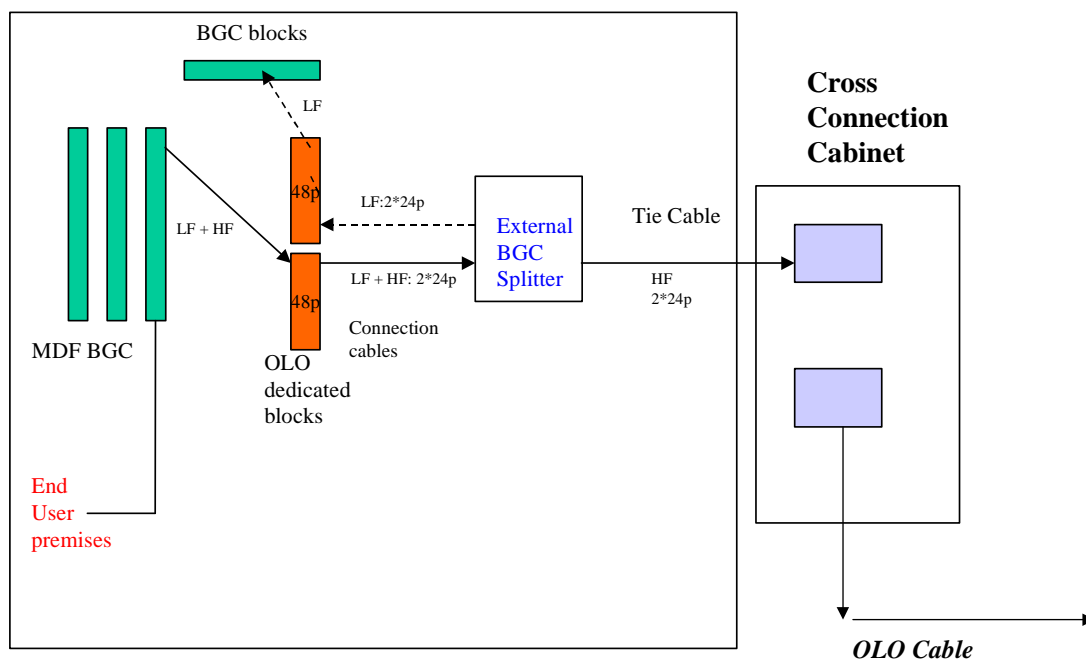

Fig. 1

- The existence of a cross connection cabinet is a prerequisite for the implementation of this service description. The construction of the cross connection cabinet is outside the scope of this agreement.

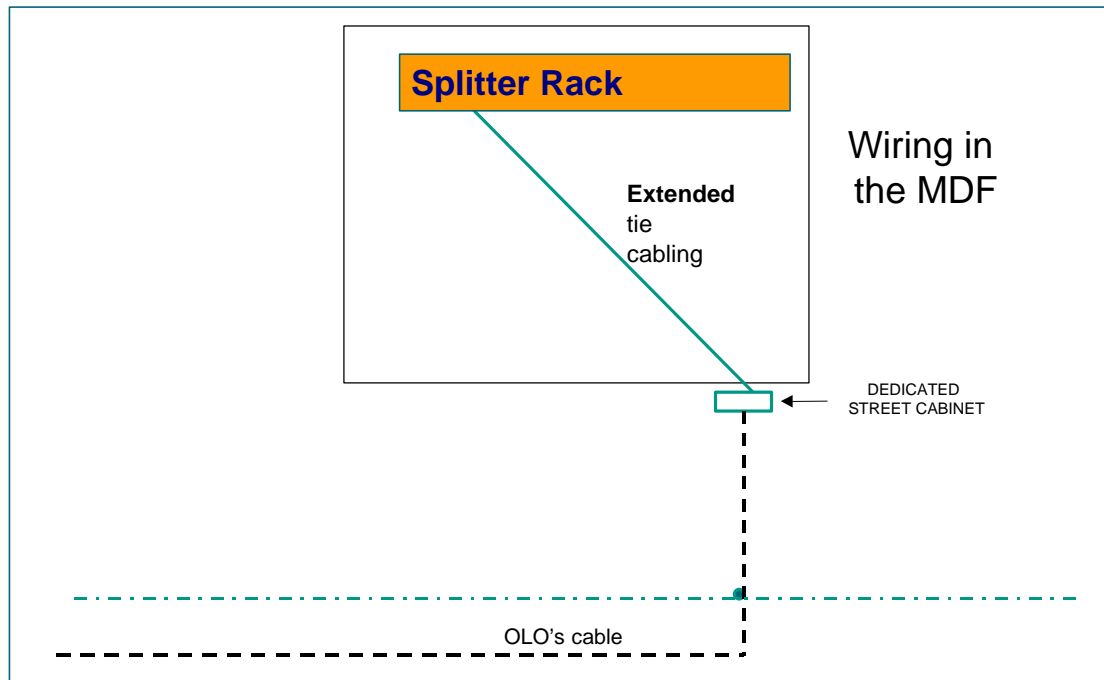

Fig. 2

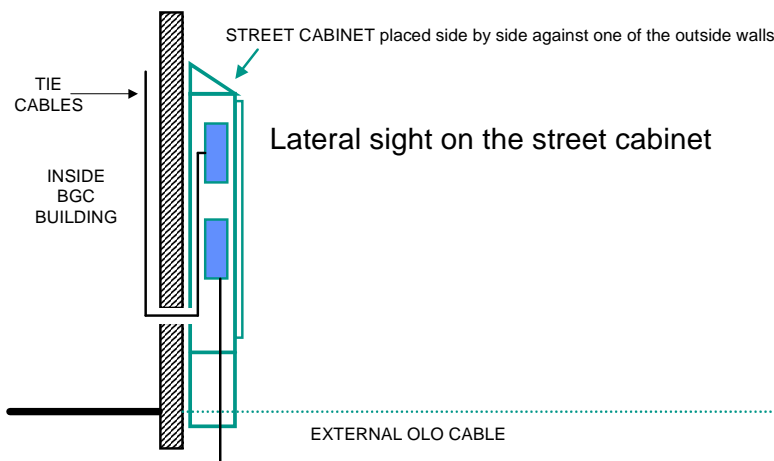

Fig. 3

- Beneficiary will order the Extended Tie Cables, Connection Cables and Blocks at Belgacom's Local Exchange building prior to the request of Shared Pair Services for individual Users. This ordering process is described in "Annex E: Planning and Operations manual".

If at a certain moment, no more free wires or positions on the blocks are available, the specific requests for individual Users, issued by the Beneficiary, will be rejected, since provisioning of that Shared Pair Service cannot be implemented.

6. The connectivity at the LEX of Shared Pair is only possible if the voice service starts in the LEX. If the voice service resides at LDC level, it can be moved if possible to LEX level in order to allow Shared Pair for that User at the LEX. The Beneficiary will pay the costs for this action.
7. The default standard unit that Beneficiary can order for the provisioning between blocks on the MDF and the Colocation area:
 - Blocks are 48 pair blocks; The minimum installation requires 2 blocks; 1 for crossconnecting high and low bandwidth, 1 for connecting low bandwidth back to the Belgacom voice switch.
 - Cables will be per 24 pairs of shielded cable. The minimum installation requires 3 times 2*24 pairs; 2 times 2*24 pairs for the Connection Cable between Beneficiary blocks and Splitter rack, 1 time 2*24 pairs for the Tie Cable to the Colocation area of Beneficiary.
 - Splitters per 48. The Splitters have to be defined –per number of 24 Splitters- as being Splitters for PSTN lines or Splitters for ISDN lines.
8. Upon specific request of the Beneficiary, the incremental unit of ordering Tie Cables can be lowered to
 - 1 Block of 48 pairs
 - Cables will be per 24 pairs of shielded cable. The installation requires 3 times 24 pairs; 2 times 24 pairs for the Connection Cable between Beneficiary blocks and Splitter rack, 1 time 24 pairs for the Tie Cable to the Colocation area of Beneficiary.
 - Splitters per 24. The Splitters have to be defined as being Splitters for PSTN lines or Splitters for ISDN lines.
9. The request for this lower increment must be explicitly notified to Belgacom. The prices for this lower increment can be found in “Annex H2.3: Price list”.

4 Distant Colocation

10. Distant Colocation is a prerequisite for the implementation of this Service Description. The installation and maintenance of colocation will be made by Belgacom, as presented in the “Belgacom Distant Colocation Agreement” attached to this Agreement.

5 Provisioning of blocks and Extended Tie Cables

11. Reference is made to “Annex E: Planning and Operations manual”.

Product	Comments
1. 48 pair blocks for the provisioning of SPP/SPI loops.	ordering per increment of 2
2. 24 pair shielded cable for the provisioning of SPP/SPI loops.	ordering per increment of 6: 4 for connection cabling, 2 for extended tie cabling
3. 48 Splitters for SPP loops or SPI loops.	Default Ordering per increment of 1

Note: The above services are settled according to “Annex H2.3: Price list”.

6 Provisioning of connectors

12. The modules in the Cross Connection Cabinet are composed of connectors. The unit that Beneficiary can order are:
- 48 connectors type LSA + (a+b+s) for SPI/SPP loops

Product	Comments
4. 48 connectors type LSA + (a+b+s) for SPP/SPI loops	ordering per increment of 1

Note: The above services are settled according to “Annex H2.3: Price list”.

13. As in Section 2, and upon specific request of the Beneficiary, the incremental unit of ordering connectors can be lowered to
- 24 Connectors of type LSA + (a+b+s) for SPI/SPP loops

14. The request for this lower increment must be explicitly notified to Belgacom. The prices for this lower increment can be found in “Annex H2.3: Price list”.

7 Jumpering in the cross connection cabinet.

15. As indicated above, the Beneficiary will be responsible for handing over the necessary cable with the required distance to Belgacom. Belgacom will be responsible for bringing the cable up to the cross connection cabinet and connecting the Beneficiary cable to the lower blocks in the cross connection cabinet.
16. The Beneficiary is further responsible for dimensioning the cable and selecting the pairs within the Beneficiary cable.

Belgacom will not be responsible for jumpering between the upper blocks and the lower blocks in the cross connection cabinet. Belgacom can also not be held responsible for any disturbances caused in the signal due to the choice between the pairs in the external Cable provided by Beneficiary going to the Beneficiary premises.

Belgacom access to the Shared Pair Services

Delivering of Tie Cable by Beneficiary

Annex B 2.4 Service Description 3040

Created on: 16 February 2012

belgacom

together with





together
with



1 Table of contents

1	Table of contents.....	2
2	Scope	3
3	Definition of service.....	3
4	Ordering Infrastructure.....	4
4.1	General	4
4.2	Prerequisites	5
4.3	Ordering procedure.....	5
5	Specific Conditions	5
5.1	Type of cable.....	6
5.2	Identification of cable.....	6
5.3	Length of cable	6
5.4	Cable delivered on reel	7
5.5	Place where to deliver the cable	7
5.6	Appointment to deliver the cable	7
5.7	Receipt of goods	8
5.8	Remove empty reel	8
6	Prerequisite for the installation of Tie Cable delivered by Beneficiary	8
7	Fault Reporting and Repair.....	9
8	Ownership and responsibilities	9
9	Financial conditions	9

2 Scope

1. This document deals with the definition of the service, equipment and application requirements for the delivering of Tie Cable by Beneficiary in case Beneficiary chooses the option to deliver its own cable. This by exception to what is stated in Service Description 3030 and Service Description 3035 as in accordance to which Belgacom automatically delivers the associated number and type of Tie Cable for every Block ordered.
2. Except for the specific provision contained the present document, the other Annexes and in particular “Annex B12: Service Description 3030” and “Annex B13: Service Description 3035” remain fully applicable.
3. The present General Terms and Conditions shall prevail on any other contractual obligations in respect to the specific subject matter “Tie Cable delivered by Beneficiary”.
4. For the sake of clarity this present Service Description applies to connection to the Physical Colocation badge or escorted access as well to connection to the Distant Colocation.

3 Definition of service

5. This Service is provided in the framework of the services as indicated in the General Terms And Conditions for the provisioning of Shared Pair in the Local Loops.
6. When Beneficiary orders the dedicated equipment at Belgacom’s Local Exchange building prior to the request of ULL Shared Pair Services, Beneficiary shall indicate on the firm order form that the delivery of the associated Tie Cable will be the responsibility of the Beneficiary.
7. Beneficiary will provide on requested date of delivery Belgacom with at least the exact length of cable on reel needed to execute the order. Place of delivery is determined by the LEX of installation.
8. Installation of the Tie Cable will only be done by the technicians of Belgacom or by the subcontractors of Belgacom.
9. For the sake of clarity the cable remains the property of Beneficiary and under its responsibility.
10. Notwithstanding what is mentioned above, the demarcation point in case of Beneficiary delivered Tie cabling will be the Splitter rack in case of Shared pair.
11. In case of tie cabling delivered by the Beneficiary, the area where the Demarcation Point is situated (area where the Splitter Rack is situated in case of Shared Pair) at the Belgacom Local Exchange or Local Distribution Center is in principle accessible to the Beneficiary for maintenance and test purposes. Beneficiary will have to justify the necessity of the planned maintenance and/or tests.

12. Beneficiary will have to substantially indicate the purpose of this access (to be mentioned with the application for guided access).
13. The access will be always with a security escort, at the expenses of the Beneficiary, and pursuant the conditions for guided access as described in the framework of co-mingling (physical colocation with escort access).
14. The connectivity at the LEX of Shared Pair is only possible if the voice service starts in the LEX. If the voice service resides at the LDC level it can be moved if possible to the LEX level in order to allow Shared Pair for that User at the LEX. The Beneficiary will pay the costs for this action.

4 Ordering Infrastructure

15. Except for the specific provisions stated in the present section 3, “Annex E: Planning and Operations Manual” remains fully applicable.

4.1 General

16. Orders are related to Beneficiary dedicated equipment at the Belgacom's LEX's. This equipment only consists in Beneficiary Horizontal Blocks. The ordered Beneficiary Blocks will be standard equipment (see “Annex C: Technical Specifications”). All installation is done by the technicians of Belgacom or by the subcontractors of Belgacom. Forecasts (if any) and Ordering are done for Beneficiary Horizontal Blocks, where for every Block ordered the associated number and type of Tie Cables will be delivered by Beneficiary.
17. When Beneficiary submits its firm order form, to order dedicated equipment at the Belgacom LEX for the preprovisioning of Shared Pair, Beneficiary will indicate that he will provide the associated Tie Cable. Beneficiary will fill in the date and hour for delivery of the cable.
18. Firm orders shall be done through the use of the specific templates available on the Belgacom secured website for LLU.
19. Templates will be considered as valid only when they are properly completed. In case data is missing or is not correct, the template will be rejected. In the latter case, Belgacom will indicate the reasons of rejection on the template. All firm orders will be submitted by registered mail to the SPOC of Belgacom for ULL.
20. For the sake of clarity, it is confirmed that for all matters related to the forecasting process will follow the guidelines as stated in “Annex E: Planning and Operations Manual”.

4.2 Prerequisites

21. As long as a Beneficiary does not have approved colocation facilities, no Beneficiary Horizontal Blocks orders can be submitted. A colocation facility is approved once the colocation Agreement has been signed and proof of payment of advance payment or 50% of the costs charged to the Beneficiary have been provided by Beneficiary.

4.3 Ordering procedure

22. The Beneficiary can order its blocks through a firm order. A firm order consists of the requested number of Beneficiary Horizontal Blocks, per type of Blocks (see Belgacom secured website for LLU) and this for each LEX. Together with the firm order, the Beneficiary includes the date when he wants the Blocks and associated Tie Cabling to be ready.
23. In the situation where cable trays are present, Tie Cable has been delivered by Beneficiary and sufficient place is available on the MDF, the delay for a firm order will be equal to the delay as stated in “Annex E: Planning and Operations Manual”.
24. In all other cases, the Beneficiary will need to take into account the delays as stated in “Annex E: Planning and Operations Manual”.
25. Belgacom will confirm the receipt of every firm order. When the installation of the Blocks and Tie Cabling is complete, the OLO will receive documentation on the position of his blocks on the MDF and on the references of the positions on the blocks. This information is important to communicate together with each order for a specific Shared Pair loop.

5 Specific Conditions

26. When delivering the Tie Cable, Beneficiary has to fulfill the following specific conditions.
If Beneficiary has not fulfilled one or more conditions, Belgacom can neither guarantee to meet its own obligations, nor to respect the delays as set in the present document and other annexes.
27. For any additional work that explicitly or implicitly needs to be done by Belgacom because Beneficiary has not fulfilled one or more conditions, Belgacom reserves the right to bill the Beneficiary for the work executed by Belgacom.

5.1 Type of cable

28. Each telecom cable consists of a number of copper conductors grouped in quads; these quads can be arranged in bundles or in layers, depending on the type of cable.
Cable delivered by Beneficiary will have to comply with the technical requirements as set by Belgacom in “Appendix A: Technical Specifications”.

5.2 Identification of cable

29. Following markings should be made in relief on the outersheath of the cable:
- Name of Beneficiary
 - The nominal number of pairs
 - The diameter of the conductors
 - The year of production
 - The name or sign of the supplier

E.g.: For a cable series 12 with 20 pairs, with conductors 0,5 mm, in 2001 made by supplier X the marking becomes: Beneficiary 12 050 5 -01 -X

30. The marking should be repeated every 500mm.

5.3 Length of cable

31. Depending on the LEX where the Tie Cable has to be installed, the length of cable will be different.
32. In “Appendix B: a list with the exact length that is needed per LEX can be found.
33. Note that this list only mentions the LEX’s where colocation facilities have already been established and the exact length of Tie Cable is already known. For other LEX’s, length will be provided by Belgacom as part of the quotation form.
- Beneficiary has to deliver to Belgacom at least the exact length of cable.
 - Length of cable may not be cumulated
 - Beneficiary will deliver per order a separate reel with the requested length of the cable.

5.4 Cable delivered on reel

34. Beneficiary will deliver the cable, reeled in an even way, on a reel.
This reel will have to comply with the specifications as set in “Appendix A: Technical specifications”.
35. The reel of the Beneficiary will be recognizable by a dedicated colour and the flange of the reels shall contain a label with:
 - Name Beneficiary
 - Name of contact person of Beneficiary
 - Telephone number where the contact person can be reached
 - The cable type
 - LEX name where the cable has to be installed
 - Order Reference Number
36. The identifications should be easy to read and should not deteriorate under atmospheric circumstances.

5.5 Place where to deliver the cable

37. Depending on the LEX where the cable will be installed, the Beneficiary will have to deliver the cable on a predefined location. A list with the LEX’s, where the colocation facilities have already been established, will indicate per LEX at which location the cable has to be delivered. See “Appendix B: List with places to deliver the cable”.

5.6 Appointment to deliver the cable

38. As the locations, where the reel with cable has to be delivered, are not free accessible and not permanently manned, the Beneficiary has to make an appointment to deliver the cable.
39. Beneficiary has to put on the firm order form his requested date and hour of delivery.
This date has to fall within the following timeframe:
 - For the date, Beneficiary can set the day to deliver the cable:
 - * At the earliest: day of ordering + 2 Working Days
 - * At the latest: day of ordering + 4 Working Days
 - For the hour, Beneficiary has to make his choice between:
 - * From 8.00 till 8.30
 - * From 8.30 till 9.00
 - * From 9.00 till 9.30

5.7 Receipt of goods

40. When Beneficiary delivers the reel with cable at the requested date of delivery, a Belgacom person will be present to take delivery of the goods.
A receipt of goods form will be filled out. See Belgacom secured website for LLU.

5.8 Remove empty reel

41. After Installation of the Tie Cable, Belgacom will bring the empty reel back to the place where Beneficiary has delivered the reel. Beneficiary will have to pick-up the empty reel at the date and hour which has been confirmed on the test & visit report.

This date has to fall within the following timeframe:

- For the date, Beneficiary can set the day to pick-up the empty reel:
 - * At the earliest: day of testing + 2 Working Days
 - * At the latest: day of testing + 4 Working Days
- For the hour, Beneficiary has to make his choice between:
 - * From 8.00 till 8.30
 - * From 8.30 till 9.00
 - * From 9.00 till 9.30

6 Prerequisite for the installation of Tie Cable delivered by Beneficiary

42. Installation of the cable will be done by the technicians of Belgacom or by the subcontractors of Belgacom.
43. Installation will be done within the timeframe, as set in “Annex E: Planning and Operations Manual”, only if all conditions linked to the delivery of the Tie Cable have been fulfilled.
44. Whenever one of the conditions for the delivery of the Tie Cable has not been met or problems linked to the cable occur during the installation, Belgacom will inform Beneficiary SPOC. The delay due to these circumstances will be added to the timeframe as set in “Annex E: Planning and Operations Manual”.

7 Fault Reporting and Repair

45. Except for the specific provisions stated in the present section 6, “Annex E: Planning and Operations Manual” remains fully applicable.
46. In case Beneficiary considers it necessary during repair to perform certain tests, specific linked to the Tie Cable, it is the responsibility of the Beneficiary to give well defined orders to Belgacom. Beneficiary will be billed for all work for which he has given the order and that has been executed by Belgacom.

8 Ownership and responsibilities

47. As mentioned in point 2, the cable remains the property of Beneficiary and under its responsibility.
48. For the sake of clarity, Beneficiary will be responsible for any damages caused by its cable to Belgacom or to any other third party.
49. For technical reasons, once the cable has been installed, Beneficiary will not be authorized to remove it, except if Beneficiary agrees to pay for the cost incurred by Belgacom to remove the cable.
50. Should the cable request technical intervention (tests in case of repair or replacement of cable), the work will exclusively be executed by Belgacom upon written request by the Beneficiary. The cost incurred by Belgacom for this intervention will be exclusively beared by Beneficiary.

9 Financial conditions

51. All charges and fees linked to the management and administrative work done by Belgacom, linked to the storage space and the installation, will be settled according to “Annex H: Price List”.

Belgacom Access to the Shared Pair Service at Local Distribution Centers
Annex B 2.5 Service Description 3015

Created on: 16 February 2012

belgacom





together
with



1 Table of contents

1	Table of contents.....	2
2	Scope	3
3	Definition	3
3.1	Product definition of Shared Pair Service	3
3.2	Network Termination Point	4
3.3	Schematically	5
3.4	Service offered by Belgacom	5
4	Connectivity to the Beneficiary Network	6
5	Colocation	6
6	Spectrum management and equipment aspects	6
7	Boundary conditions and prerequisites	6
8	Ordering of Shared Pair.....	8
8.1	Standard provisioning rules	8
8.2	Termination of the voice subscription with Shared Pair	10
8.3	Non-standard provisioning rules	11
9	Wrongful repair requests.....	11

2 Scope

1. This Service Description deals with the definitions of services, equipment and application requirements and properties of the Belgacom Offer for Shared Pair Service as described under section 2.4; and the procedures for ordering of and fault reporting to Belgacom with respect to the Service described herein.

3 Definition

3.1 Product definition of Shared Pair Service

2. A Raw Copper Loop is a pair of fully metallic copper wires on the section between Belgacom's Main Distribution Frame at the Belgacom LDC and the User's site connected on a Network Termination Point.
3. The Shared Pair Service is the service by which Belgacom provides to an Beneficiary an access to an User by means of a part of the frequency of a Raw Copper Loop, whereby the entire frequency of the loop concerned is shared by Belgacom and the Beneficiary as follows:
 - Belgacom provides PSTN or ISDN BA services to the User (for which a Full Subscription Fee is paid for by the User concerned) on the voice frequency part (also referred to in the present document as the low bandwidth) of that Raw Copper Loop
 - Beneficiary provides data services to the same User based on ADSL technology on the non-voice frequency part (also referred to in the present document as the high bandwidth) of that same Raw Copper Loop
4. The Shared Pair Service requires that the User maintains his single line PSTN or ISDN BA Belgacom service for which a Subscription Fee is paid for by the User concerned. "Annex E: Planning and Operations Manual", describes the procedures that are applicable in case of modifications or cancellations requested by the User of the single line Belgacom PSTN or ISDN BA Service. Any modification or a cancellation of the single line PSTN or ISDN BA Belgacom service requested by the User, will affect the access to or the price of the Shared Pair Service by the Beneficiary.
5. A Shared Pair Service can therefore only be offered on a single, non-loaded and active pair. No load coils or other active equipment can be present in the circuit.

In case load coils or other active equipment are present in the circuit, Belgacom will provide a process for proceeding with a new pair choice if technically feasible. For these services by Belgacom, the Beneficiary will be charged the related extra fee that will be included in "Annex H": Pricing.

6. Beneficiary has the right to gain access to Shared Pair Service at the Main Distribution Frame level of the LDC, where Belgacom will install and maintain the necessary equipment to split the high frequency that is delivered to Beneficiary and the low frequency used by Belgacom. For details and definitions of the high and the low bandwidth, reference is made to "Annex C: Technical Specifications Document".

7. The access to the high bandwidth at the Belgacom network side will be realized on the Belgacom Main Distribution Frame (MDF) by using dedicated Blocks per Beneficiary. From there, a pair of physical wires will be connected to the splitter rack (Connection Cables) and brought back from the Splitter rack to Beneficiary dedicated blocks for the low frequency. From the Splitter rack, connections will be made to the collocation area of the Beneficiary by use of Tie Cables in case of Physical collocation and by use of Extended Tie Cables in case of Distant collocation.
8. At the LDC or the Local Distribution Center, the Demarcation Point will be
 - in case of Physical or Virtual Colocation: the point on the Tie Cable just before it is connected to the collocated equipment of the Beneficiary..
 - in case of Distant Colocation: the Connectors in a Cross Connection Cabinet in the immediate vicinity of the Belgacom Local building.
9. The demarcation point in case of Beneficiary delivered Tie cabling shall be the Beneficiary dedicated Blocks on the MDF in case of Raw Copper. In case of Tie cabling delivered by the Beneficiary, the Beneficiary has access to the area where the demarcation point is situated (MDF area in case of Raw Copper) at the Belgacom Local Exchange or Local Distribution Center for maintenance and test purposes. Beneficiary shall have to justify the necessity of the maintenance and/or tests planned. Beneficiary shall have to indicate the purpose of his access substantially (to be mentioned with the application for guided access). Access shall always be with a security escort, at the expense of the Beneficiary, and pursuant to the conditions for guided access as described in the framework of co-mingling (physical collocation with escort access).

3.2 Network Termination Point

10. The access to the high bandwidth at the User site will be at the Belgacom Network Termination Point (NTP).
11. For single line PSTN Service, the Beneficiary will install the equipment on the Belgacom Network Termination Point at the User site.
For single line ISDN BA service, an intervention of a Belgacom technician on the User site will be required in case the User site does not have an AETHRA NT1-2ab as Belgacom Network Termination Point. At the time of installation, this intervention will relate to the fact that, in these cases, a Splitter will be installed by Belgacom between the Belgacom Network and the Network Termination Point at the User site.

3.3 Schematically

Belgacom LDC

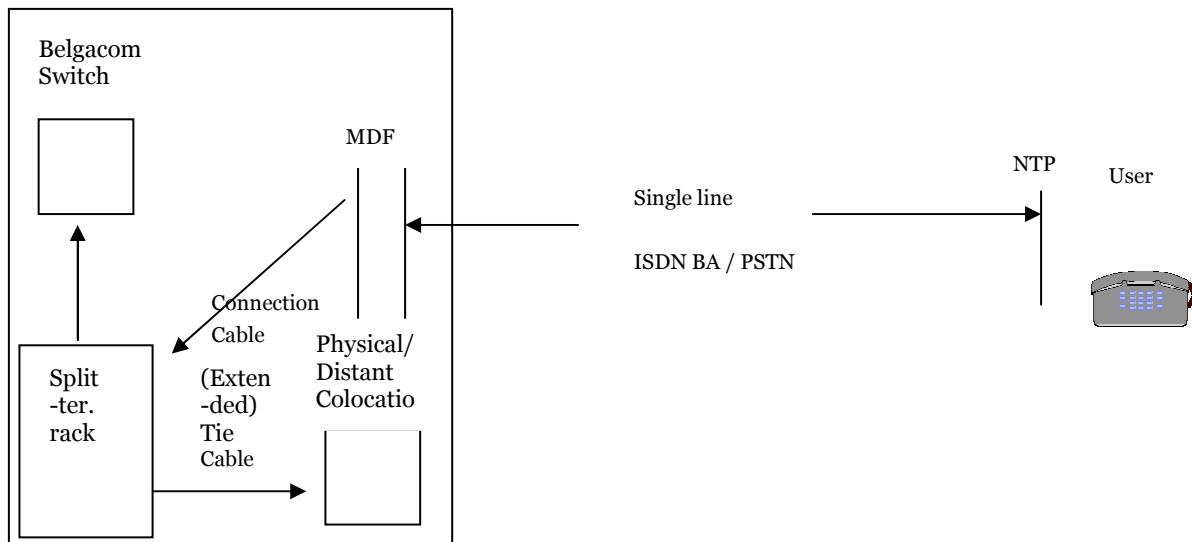

Fig. 1

For details on the Connection Cables and Tie Cables, reference is made to Service Description 3030 and 3035.

3.4 Service offered by Belgacom

12. The use of a Shared Pair is free, provided that the Beneficiary complies with the “Spectrum Management” rules described in the Annex C. Depending on the type of equipment that is directly connected to the unbundled Local Loop, different rules for the bringing into service and for the service level can be applicable.
13. SPP (Shared Pair Service over PSTN)
 - The high frequency band on the loop is to be used to connect ADSL equipment providing ADSL service capable of co-existing on the same pair as voice-band services (ADSL over PSTN). For technical details on the signals to be used, reference is made to “Annex C: Technical Specifications document”.
14. SPI (Shared Pair Service over ISDN)
 - The high frequency band on the loop is to be used to connect ADSL equipment providing ADSL service capable of co-existing on the same pair as ISDN Basic Access services (ADSL over ISDN). For technical details on the signals to be used, reference is made to “Annex C: Technical Specifications document”.

4 Connectivity to the Beneficiary Network

15. At the Belgacom LDC, the copper wires are terminated on the Main Distribution Frame. Beneficiary's access to the copper wire pairs will be established by connecting Tie Cables from the Main Distribution Frame of the exchange to colocation area in case of physical colocation and by connecting Extended Tie Cables from the Main Distribution Frame of the exchange to the Cross Connection Cabinet in case of distant colocation.
16. The installation and maintenance of the (Extended) Tie Cable and the provisioning and maintenance of the Blocks will be made by Belgacom, as presented in Service Descriptions 3030 and 3035.

5 Colocation

17. For the provision of Colocation Services reference is made to the Colocation Agreement. Subscriptions to this agreement is a pre-requisite to install equipment in a Belgacom building. For the sake of clarity, Colocation Services can only be used to benefit from specific Belgacom Services requiring colocation.

6 Spectrum management and equipment aspects

18. "Annex C: Technical Specifications Document"* to the contract, contains the requirements related to spectrum management and equipment connected for use of the shared pair.

7 Boundary conditions and prerequisites

19. The Beneficiary is only allowed to use the Shared Pair Service for the purpose described in Section 2.4.
20. All equipment used by the Beneficiary will comply with the R&TTE Directive.
21. It is noted that Belgacom will not undertake customer care handling of Users of the Beneficiary. If Belgacom receives requests from Users of the Beneficiary due to the inadequate handling of such requests by the Beneficiary, Belgacom will not deal with them.
22. In case there is a change in Shared Pair Service type, the Beneficiary will address a request for a deactivation and an installation to Belgacom, in order to obtain the requested modification.

23. If equipment or network components, that are operated by Beneficiary for its own use and that are connected to Belgacom's public telecommunications network, cause disturbances in Belgacom's network, Beneficiary shall be required to disconnect the User connection without any delay.
24. Belgacom shall use, in good faith, all reasonable endeavours to correct any trouble affecting the quality of service Belgacom is providing to its own Users. In this respect, Belgacom is entitled to disconnect Beneficiary's connection to Belgacom's access network, on the basis of User complaints, reports from the operational services of Belgacom, etc., and provided that Belgacom can demonstrate that Beneficiary's systems cause service degradation or disruption of the services offered by Belgacom in the network.

8 Ordering of Shared Pair

25. Belgacom shall deliver access to the high bandwidth according to Beneficiary's orders transmitted to Belgacom. The general terms and conditions for delivering high bandwidth are defined in "Annex E: Planning and Operations manual"*.
26. The full details of the provisioning process can be found in "Annex E: Planning and Operations manual".

8.1 Standard provisioning rules

27. The Beneficiary can obtain the following standard Shared Pair Services:

Service	Contents	Fee
1. Inquiry	Examination of whether Shared Pair Service can be provided	Inquiry Fee (not to be paid if the inquiry is followed by a request)
2. Request for Shared Pair Service	Physical connection of the Shared Pair Service to the Beneficiary Network	Installation fee
3. Cancellation of Requests	Orders that have been placed by the Beneficiary but that are cancelled prior to implementation	Cancellation fee
4. Deactivation of Shared Pair Service	Belgacom disconnects the Shared Pair Service from the Beneficiary dedicated Blocks	Deactivation fee
5. Change Date	The Beneficiary requests a change in due date for the provisioning of the Shared Pair Service	Change date fee
6. NTP Intervention	If Belgacom needs to intervene at User site for the installation of a full-rate splitter	Telecom Installation fee, invoiced on top of the Installation fee
7. Transfer	Transfer of a Shared Pair Service from Beneficiary 1 or Belgacom to Beneficiary 2	Is inferior to the installation fee (deactivation is at charge of Beneficiary 1)

Further comments:

28. On point 1

The purpose of an Inquiry is to investigate the availability of the Shared Pair Service at a particular User site. This inquiry consists of verifying whether an existing end to end single line PSTN or ISDN Belgacom service is available and of carrying out a pair selection test to verify that the Shared Pair Service, as indicated by the Beneficiary, can coexist with the surrounding pairs. An inquiry gives only the status of a of the User line at one specific moment in time. Belgacom guarantees the accuracy of the information provided at the moment of the inquiry, without prejudice to any subsequent change in the technical situation.

29. On point 2

The Beneficiary will indicate on his order form the date the Beneficiary wishes Belgacom to provision the Shared Pair Service.

30. When the Beneficiary places a firm order for the Shared Pair Service, Belgacom will also carry out a check whether the current existing single line ISDN or PSTN service is capable of supporting the high bandwidth signal requested by the Beneficiary. Belgacom will perform additionally a pair selection test to verify that the service, as ordered by the Beneficiary, can coexist with the surrounding pairs.

31. On new pair selection

In case the order can not be implemented on the ISDN BA or PSTN service due to the presence of load coils or other active equipment on the existing single pairs, Belgacom will inform the Beneficiary of this fact according to the process described in “Annex E: Planning and Operations manual”

When the Beneficiary does not confirm his Request at that time, the Request will be implemented if technically feasible and the Beneficiary will be billed for the other pair selection choice according to the different elements as set out in “Annex H2.1: Price List”

32. Belgacom will inform the Beneficiary in good faith, as soon as possible, of the modifications of the current ordering procedures by means of an Appendix to “Annex E: Planning and Operations Manual”.

33. In case the order cannot be implemented because of technical reasons (of which Belgacom has to publish a limitative list that can be adapted on a case by case basis afterwards), the Beneficiary's Request will be rejected. If the Request for Shared Pair Service can be implemented, Belgacom will proceed with the implementation of that firm order.

34. On point 3

The Beneficiary has the right to cancel an order that it has submitted to Belgacom for the implementation of a Shared Pair Service. However, Belgacom will bill the Beneficiary for the work done in the process.

35. On point 4

The Beneficiary can request the Deactivation of the Shared Pair Service at a particular User site

36. On point 5

The Beneficiary has the right to change the date it indicated at the time of transmitting the Request for the Shared Pair Service. In such a case, the Beneficiary will be billed a change date fee.

37. On point 7

When there is a transfer from Shared Pair Service from Beneficiary 1 to Beneficiary 2, it is presumed that two Beneficiaries, according to agreement with the User, handle the removal of the User's services and co-ordinate the hand over of the Shared Pair Service.

It is acknowledged that Belgacom will only transfer the Shared Pair Service from Beneficiary 1 to Beneficiary 2 upon request of Beneficiary 2 solely. Belgacom will terminate the contract for that specific Shared Pair Service by informing Beneficiary 1 of the request from Beneficiary 2, without revealing the identity of Beneficiary 2.

Belgacom handles the request of the Beneficiary 2, taking over the Shared Pair Service. Belgacom does not in any case handle complaints between Beneficiary 1 and Beneficiary 2.

38. The different services, as described above, are settled according to "Annex H2.1: Price list". For the installation fee, different price setting can apply to different types of installations based on the work done by Belgacom after approval by BIPT. Reference is made to Annex H2.1.

8.2 Termination of the voice subscription with Shared Pair

39. In case of a Shared Pair Service where both Belgacom and the Beneficiary provide services to an User, it can occur that the User cancels his voice subscription for that Shared Pair Loop. In that case, independent of the reason for termination of the voice subscription, Belgacom will ensure that the service on the high bandwidth remains into service. This is applicable in condition that positions on Belgacom Horizontal blocks that are not connected are available at the MDF.

40. Belgacom will inform the Beneficiary that the Shared Pair Service has been converted to a Raw Copper + Splitter, for which the Beneficiary will be charged the monthly rental fee for Raw Copper instead of Shared Pair. For the change to Raw Copper + splitter, no conversion fee is applicable. The Beneficiary has at that moment the possibility to ask for a conversion from its Shared Pair to a Raw Copper and will by this free up a dedicated Splitter Card. In this case, a conversion fee will be charged to the Beneficiary.

41. In case the Raw Copper + Splitter stays active and is not converted into Raw Copper, the terms and conditions applicable on repair and maintenance will be the terms and conditions applicable to Raw Copper Services as described in the Belgacom Reference Offer and the related documents.

42. A change to Raw Copper is only possible if Beneficiary concerned subscribed, next to Shared Pair, to a Raw Copper contract and if positions are free on the dedicated horizontal OLO blocks under that raw copper contract.
43. If the Beneficiary decides to convert the Raw Copper + Splitter into Raw Copper, Beneficiary is notified of the fact that an interruption of its service during a limited timeframe (defined in hours) will take place in order to do the re-jumpering.
44. For the sake of clarity, this process can only take place pursuant to the General Terms and Conditions and if the necessary infrastructure is in place to do the re-jumpering, without prejudice to other conditions that are currently being investigated from a process point of view.

8.3 Non-standard provisioning rules

45. In case the request for implementation of Shared Pair Service can not be executed, Beneficiary request will be rejected.
46. Belgacom will reject the requests if:
 - no single line PSTN or ISDN BA Belgacom Service is provided to the User concerned;-the requested service is incompatible with the Belgacom pair selection rules.
 - Belgacom will also reject requests if no positions and/or pairs are available on the Beneficiary Blocks, (Extended) Tie Cables and Connection Cables
47. Belgacom also will reject the requests if a new pair choice is reasonably and/or technically not possible over the existing infrastructure which must be detailed and proved to the Beneficiary.
48. Belgacom further reserves the right to reject requests for implementation of a Shared Pair Service for a Beneficiary based on wrong format data. The rejection list can be found in “Annex E: Planning and Operations manual”.

9 Wrongful repair requests.

49. Belgacom’s fault repair of Shared Pair Service between the Main Distribution Frame at the LDC and the User NTP is included in the periodic payment for the Shared Pair. The procedures for that fault reporting are described in “Annex E: Planning and Operations manual”.
50. In case of a repair request where the fault was not caused by Belgacom and Belgacom has performed work for that repair request, Belgacom reserves the right to bill the Beneficiary for the work done by Belgacom in light of that specific request according to “Annex H2.1: Price list” It is noted that Belgacom in a first phase will not automatically charge the Beneficiary for wrongful repair requests.

Belgacom access to Shared Pair Service

Connection to the colocation

Local Distribution Center (LDC)

Annex B 2.6 Service Description 3045

Created on: 16 February 2012

belgacom

together with





together
with



1 Table of contents

1	Table of contents.....	2
2	Scope	3
3	Definition	3
4	Order increments	5

2 Scope

1. This Service Description handles the definitions, equipment and application requirements for the connection of the Shared Pair Service to the Colocation of the Beneficiary.
2. Colocation is a prerequisite for the implementation of this Service Description. The installation and maintenance of colocation will be made by Belgacom.

3 Definition

3. The following cases of Belgacom colocation exist:
 - (1) Colocation within the LDC1
 - (2) Street cabinet adjacent to the LDC2
 - (3) Beneficiary will bring the cabling up to the LDC3, the demarcation point is determined at the MDF in the LDC4

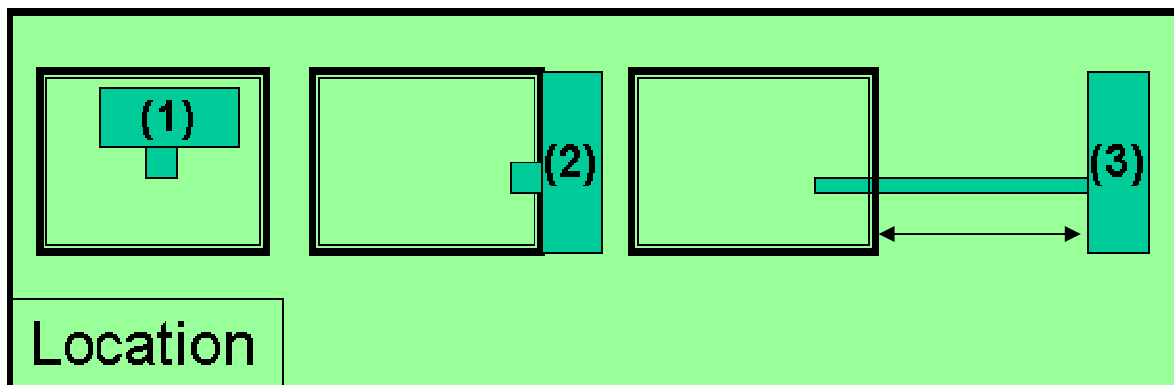

Fig. 1: Cases of Belgacom colocation

¹ Applicable for colocation case 2.2.1 and 2.2.2 in Service Description 'Colocation at the LDC Level'

² Applicable for colocation case 2.2.3 in Service Description 'Colocation at the LDC Level'

³ Applicable for colocation case 2.2.4 in Service Description 'Colocation at the LDC Level'

⁴ The cable will be installed by the Beneficiary up to the entrance of the LDC, the cable specifications will be agreed between Belgacom and Beneficiary

At the Belgacom LDC, the copper wires are terminated in the Main Distribution Frame. Beneficiary's access to the Shared Pair Service will be established with Connection Cables and Tie Cables from the Main Distribution Frame of the Belgacom LDC to Beneficiary's colocation in that same Belgacom LDC.

4. Both the high and low frequency are brought to dedicated Beneficiary blocks. From a 48 pair block, a Connection Cable brings the high frequency and the low frequency to the Splitter Rack of Belgacom. The low frequency is brought back to another or the same 48 pair Beneficiary block. A Cable is connected from this position to a Belgacom horizontal block that leads to the voice switch of the Splitter Rack and the

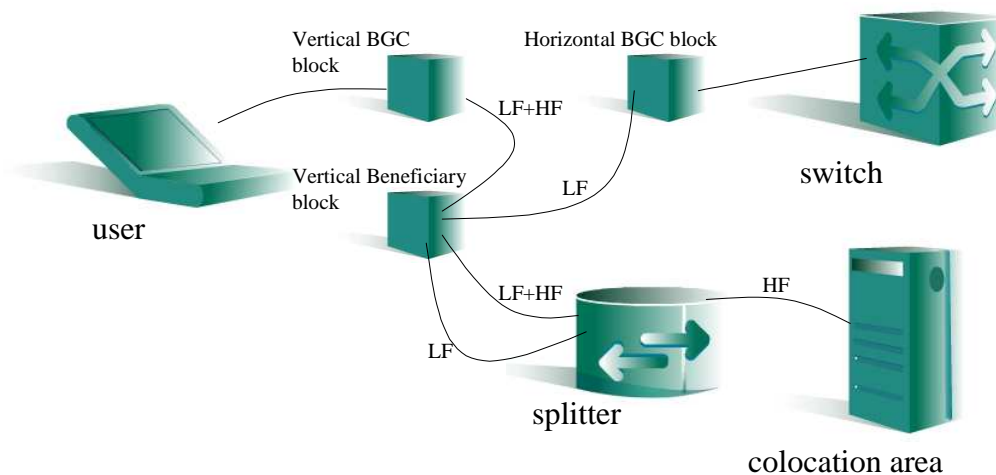

LF: Low frequency, HF: High Frequency

Fig. 2: Connection to the colocation

5. Beneficiary will order the Tie Cables, Connection Cables, Blocks and Splitters at Belgacom's LDC prior to the request of Shared Pair Services for individual End Users. This ordering process is described in "Annex E: Planning and Operations manual".
6. If at a certain moment, no more free wires or positions on the blocks are available, the specific requests for individual End Users, issued by the Beneficiary, will be rejected, since provisioning of that Shared Pair Service cannot be implemented.
7. The connectivity at the LDC of Shared Pair is only possible if the voice service starts in the LDC.

4 Order increments

8. The default standard unit that Beneficiary can order for the provisioning between blocks on the MDF and the colocation are:
 - 24 connections in case of LDC Building or LDC Cabinet colocation for connection of shared pair services: the blocks on the MDF will be 1x48 pair blocks, the cabling 3x24 pair shielded cables, Splitters 1x24 defined as being Splitters for PSTN or/and ISDN.
 - 24 connections in case of LDC Cabinet or LDC Cross connection cabinet for connection of shared pair services: the blocks on the MDF will be 1x48 pair blocks, the cabling 3x24 pair shielded cables, Splitters 1x24 defined as being Splitters for PSTN or/and ISDN, inside the cabinet the Tie Cabling will be terminated on LSA blocks.

Annex Ja Initial Information available to Operators

Created on: 16 February 2012

belgacom



1 Table of contents

1	Table of contents.....	2
----------	-------------------------------	----------

- 1 The secured Belgacom website contains the Annex J to the present Belgacom Reference ULL Offer, network information and other operational documents:
 - Annexes J:
 - Annex Ja - Initial Information available to Operators
 - Annex Jb - Non Disclosure Agreement
 - Annex Jc - Technical Specifications Tie Cabling
 - Annex Jd - Pair Selection Rules for Raw Copper Type 1 loops
 - Annex Je - Pair Selection Rules for Raw Copper Type 2 loops
 - Annex Jf - Pair Selection Rules for Shared Pair loops
 - Annex Jg - Transmission properties of the access network
 - Annex Jh – KVD Streets Information
 - Belgacom Network Information: Netcode limits, List of LEX's, List of LDC's, List of KVD's, List KVD – looplevelength, List LDC-KVD, List LEX-KVD, PQYZ per local
 - Operational Documents: Manual LLU Web Tools, Order Form for Equipment, XML files, DTD files, XML Manual, ...
 - Operational agreement: delivery of NTP

- 2 Prior to the provision of such information to an interested party eligible to benefit¹ from ULL Services; the concerned party will have to sign a Non Disclosure Agreement. Such Non Disclosure Agreement has been included in the present Annex J.

- 3 The signed Non Disclosure Agreement can be sent to the ULL Point of Contact at Belgacom, of which the coordinates are included in §1.5 of the present Reference Offer.

- 4 This Point of Contact can also be addressed for any further questions or remarks or requests for information regarding the present information or the procedure to obtain it.

¹ If refusal Belgacom will inform BIPT

Annex Jb Non-Disclosure Agreement

Created on: 16 February 2012

belgacom



1 Table of contents

1	Table of contents.....	2
2	Non-Disclosure Agreement.....	3
3	Confidential Information.....	4
4	Non-Disclosure.....	5
5	Disclosure to Personnel, Advisors or Suppliers.....	5
6	Disclosure Required by Law.....	6
7	Limited Scope.....	7
8	No Representation or Warranty.....	7
9	Return of Confidential Information.....	7
10	Duration.....	8
11	Miscellaneous.....	8

2 Non-Disclosure Agreement

This non-disclosure agreement (“Agreement”) has been made

Between

Customer, a company incorporated under the laws of ..., with registered office and place of business at ..., registered with the Brussels Register of Legal Entities under number [xxx].

(hereinafter "Customer")

and

Belgacom NV/SA, a Belgian autonomous public enterprise organized under the Law of March 21, 1991, and the Royal Decree of August 19, 1992, with registered office and place of business at 1030 Brussels, 27 Boulevard Roi Albert II, registered with the Brussels Register of Legal Entities under number 202.239.951.

(hereinafter "Belgacom")

Both parties to this agreement being hereafter referred to, collectively, as the “Parties”, or, individually, as a “Party”

Witnesseth as follows:

Whereas, the Parties have shown interest to obtain information with respect to the unbundling of the local loops in the Belgacom network as described in the Belgacom’s Reference ULL Offer (the “Business Purpose”);

Whereas, in the framework of these discussions, the Parties may need to disclose to one another confidential information with regard to products, processes, commercial, research and development activities or, in general, any know-how in relation to their respective business activities.

Whereas, in order to protect the respective proprietary interest of the Parties in the information that each of the Parties might disclose to the other, the Parties have decided to agree on the terms and conditions subject to which such confidential information will be disclosed.

Now, therefore, in consideration of the mutual covenants herein contained, the Parties do agree as follows:

3 Confidential Information

3.1 In this Agreement, the term “Confidential Information” shall mean:

- Any information in any form communicated by one Party (or from any of its Associated Companies as defined in Section o of this Agreement) (the “Disclosing Party”) to the other Party (or to its employees and advisors) (the “Receiving Party”) in connection with the Business Purpose, or obtained by the Receiving Party in connection with the Business Purpose, provided that such information is, at the time of its disclosure, designated, labeled or marked "confidential" or with an equivalent term. If such information was disclosed orally, it shall constitute Confidential Information provided that (i) a written notice containing a summary of the information disclosed orally and mentioning that such information is confidential, is issued by the Disclosing Party to the other within thirty days from the date of disclosure, or (ii) such disclosure is recorded in minutes of a meeting that are designated, labeled or marked "confidential" or designated, labeled or marked with an equivalent term.

and

- Any information communicated by the Disclosing Party to the Receiving Party in connection with the Business Purpose, or obtained by the Receiving Party in connection with the Business Purpose, which derives economic value, actual or potential, from not being generally known to persons other than the Disclosing Party, or which, by its nature, or, under the circumstances, are to be kept secret or confidential.

3.2 Any Confidential Information communicated or obtained prior to the conclusion of this Agreement shall be considered in the same manner and be subject to the same treatment as the Confidential Information disclosed after such date, provided that such Confidential Information is specifically identified by the Disclosing Party in a written notice sent to the Receiving Party within 30 days after the date of this Agreement.

3.3 For purposes of this agreement, "Confidential Information" does not include:

- information that is properly and lawfully in the public domain otherwise than by breach of this Agreement or any other obligation of confidence, as can be demonstrated on the basis of published documents and other evidence. Notwithstanding the foregoing, information that is specific to certain data will not be deemed to be in the public domain merely because such information is embraced by more general disclosures in the public domain. In addition, any compilation of public information, but which is set forth in a format which is not publicly available, will not be deemed as being in the public domain;
- information that was disclosed by a third party to the Receiving Party without restriction on disclosure or use, unless the Receiving Party had actual knowledge that this information was acquired unlawfully or by a breach of contract or fiduciary relationship.

3.4 Information that does not constitute a trade secret will cease to be Confidential Information on the third anniversary of the first date of disclosure thereof by one Party to the other.

3.5 The term "Associated Companies" of a Party shall mean any subsidiary and/or parent company of such Party, together with any subsidiaries of such parent company. In this agreement, the terms parent and subsidiary company shall be understood as meaning, in the case of a parent company, only the companies which, directly or indirectly, hold more than fifty percent of the outstanding voting shares of the relevant company and, in the case of a subsidiary company, only the companies in which the relevant company holds, directly or indirectly, more than fifty percent of the outstanding voting shares.

4 Non-Disclosure

- 4.1 The Receiving Party shall refrain from disclosing the Confidential Information to any third party and shall use the Confidential Information only for the Business Purpose or the negotiation of any agreement related to the Business Purpose. In addition, the Receiving Party shall take any and all measures to ensure the confidentiality of this information. In any event, the Receiving Party shall use efforts commensurate with those that such Party employs for protecting the confidentiality of its own Confidential Information.
- 4.2 Notwithstanding the foregoing, either Party shall be allowed to disclose the Confidential Information to third parties provided it has obtained the prior written consent of the other Party. Such written consent will be given case-by-case upon a discretionary basis. Such written consent shall only be valid and enforceable for the specific information listed therein. The written consent to disclose Confidential Information shall identify the third party or parties to which the information can be disclosed and shall set forth the terms and conditions to which such disclosure is subject.
- 4.3 Notwithstanding the general application of the provisions of Section 0, the Receiving Party shall not use the Confidential Information in any way detrimental to the Party who consented to the disclosure.
- 4.4 The Disclosing Party shall remain free to disclose to third Party Confidential Information disclosed to the Receiving Party.

5 Disclosure to Personnel, Advisors or Suppliers

- 5.1 A Receiving Party shall disclose the Confidential Information received from the other only to its employees, agents, directors, consultants or advisors who have a need to know such information because they are directly involved in the assessment, evaluation of or negotiation of agreements related to the Business Purpose. Such Party shall ensure that such employees, agents, directors, consultants or advisors are bound by the obligations of confidentiality in respect of the Confidential Information that are set forth in this Agreement.
- 5.2 Customer and Belgacom shall be entitled to disclose the other Party's Confidential Information to the employees, agents, directors, consultants or advisors of their Associated Companies, as stipulated in Article 3 hereabove, on the same terms as they can disclose the Confidential Information to their own management and employees subject to the obligations contained in Clause 1 of this Article.
- 5.3 Notwithstanding anything to the contrary in the foregoing provisions, each of the Parties undertakes not to disclose Confidential information to business divisions of their organization or business division of their Associated Companies that are engaged in activities competing with the other Party, unless such disclosure would be required for the Business Purpose, in which case no use whatsoever shall be made of this Confidential information for any purpose other than the Business Purpose.
- 5.4 Either Party shall be entitled to disclose Confidential Information which they received from the other Party to this Agreement to their suppliers of goods and services provided and to the extent that they are able to demonstrate that these suppliers effectively require to have access to such information in order to supply the relevant goods and services. The Parties shall do whatever is necessary in order to impose on the suppliers which have obtained access to Confidential Information under the present provision obligations to keep this information confidential which are at least equivalent to the obligations imposed under this Agreement.

- 5.5 Each Party shall be fully liable for any unauthorized disclosure or use of the Confidential Information by its employees, agents, directors, consultants, advisors or suppliers. Each of the Parties agrees, at its sole expense, to take all responsible measures (including but not limited to court proceedings) to restrain its employees, agents, directors, consultants, advisors or suppliers from prohibited or unauthorized disclosure or use of the Confidential Information.

6 Disclosure Required by Law

- 6.1 If the disclosure of Confidential Information to third parties is required by law, the Receiving Party shall refrain from disclosing the Confidential Information until it has informed the Disclosing Party in writing of the reasons and nature of the proposed disclosure. The Disclosing Party shall have a reasonable term to (i) make known its opinion with regard to the need to disclose the relevant information and with regard to the scope and nature of the information to be disclosed; to (ii) seek a protective order or other appropriate remedy or to (iii) waive compliance with the obligations of this Agreement.
- 6.2 If the Disclosing Party considers that the disclosure of Confidential Information is not required by law and in the absence of a protective order or other remedy, Parties shall designate a mutually acceptable counsel who shall decide whether the disclosure is required by law. Any expenses and costs flowing from the use of such a counsel will be borne by the Disclosing Party unless the claim for disclosure can be considered as unreasonable or frivolous.
- 6.3 If the Disclosing Party waives the obligations under this Agreement or if counsel decides that disclosure is required, the Receiving Party shall be entitled to disclose only that portion of the Confidential Information which is designated by the Disclosing Party or by counsel to be subject to disclosure required by law.
- 6.4 Parties shall cooperate to preserve the confidentiality of the information disclosed under this Agreement including, where relevant, by cooperating to obtain a protective order or other reliable assurance that confidential treatment will be granted by the addressee of the disclosure. Any costs flowing therefrom shall be borne by the Disclosing Party.
- 6.5 Without prejudice to the application of the foregoing, in the event that a disclosure to a competent government authority is required to ensure compliance with applicable laws, the Parties shall endeavor to ensure the confidential treatment of the Confidential Information by such government authorities.
- 6.6 The provisions of this agreement are without prejudice to the right of each of the Parties to disclose Confidential Information to the BIPT (Belgian Institute for Post and Telecommunications) where (i) such disclosure is necessary to comply with any general or specific reporting obligations of the Party concerned or where (ii) such disclosure is made in the context of formal proceedings initiated in front of the BIPT. If any such disclosure of Confidential Information is made, the Party communicating the information concerned will ensure that the attention of the BIPT is properly drawn to the fact that the information is confidential and that the information needs to be kept confidential.

7 Limited Scope

- 7.1 This Agreement applies only in respect to those rights and obligations that are explicitly referred to herein. Nothing in this agreement shall be construed as, directly or indirectly, granting or conferring upon the Receiving Party any right of transfer and/or license under any patent, copyright, know-how, trademarks, registered trade names, service marks or any other right (including intellectual or industrial property rights), which is owned by or licensed to the other Party or which such other Party should acquire in property or by way of license.
- 7.2 The disclosure of Confidential Information shall not constitute an encouragement to infringe any industrial and/or intellectual property rights of third parties. The exchange of information shall not constitute any representation, warranty, assurance or guarantee with respect to the infringement of these rights.

8 No Representation or Warranty

- 8.1 Except as set forth in a subsequent definitive agreement between the Parties, neither Party shall be deemed to have made any representation or warranty as regards the accuracy or completeness of the Confidential Information communicated under this Agreement.
- 8.2 Neither Party nor any of its representatives shall have any liability to the other Party or its representatives relating to or resulting from the use of the Confidential Information, except in case of intentional or gross negligence.

9 Return of Confidential Information

- 9.1 If either Party decides that it does not wish to participate with the other in a transaction in relation to which Confidential Information was disclosed, it will promptly inform the other Party of that decision. In that case, any documents, designs, drawings, models, samples, computer software or other tangible items, in either electronic or paper format, constituting Confidential Information and communicated by the Disclosing Party (“Primary Materials”) shall be returned by the Receiving Party at the request of the Disclosing Party. In addition, at the request of the Disclosing Party, all copies of the Primary Materials will, be destroyed or returned to the Disclosing Party and the Receiving Party shall certify in writing to the Disclosing Party that all such copies have been destroyed or returned to the Disclosing Party.
- 9.2 Any notes, analyses, compilations, comparisons, studies, interpretations or other similar documents prepared by a Receiving Party, its employees, agents, directors, consultants or advisors, which contain, reflect or are based upon, in whole or in part, the Confidential Information (“Derivative Materials”) will be kept by such Party and shall be kept confidential by it, or will be destroyed by it if so requested by the Disclosing Party. In the latter case, the Receiving Party shall certify in writing to the Disclosing Party that the Derivative Materials, including all copies thereof, have been destroyed or returned to the Disclosing Party.

10 Duration

- 10.1 This Agreement shall take effect on the date of conclusion of this Agreement and shall remain in force until the end of the third year following of the last disclosure of Confidential Information covered by this Agreement.
- 10.2 In the event that the Parties enter into one or more agreement related to the Business Purpose, the confidentiality provisions contained in that agreement will supersede the provisions of this Agreement.

11 Miscellaneous

- 11.1 In the event any one or more of the provisions contained in this agreement shall for any reason be held to be invalid, illegal or unenforceable in any respect, such invalidity, illegality or unenforceability shall not affect any other provision of this agreement. This agreement shall be construed as if such invalid, illegal or unenforceable provision had never been set forth herein, and the agreement shall be carried out as nearly as possible according to its original terms and intent.
- 11.2 No failure or delay by either of the Parties in exercising any right, power or privilege hereunder shall operate as a waiver thereof, nor shall any single or partial exercise thereof preclude any other or further exercise thereof or the exercise of any right, power or privilege hereunder.
- 11.3 In the event of a breach by either of the Parties of any or all of the terms or conditions contained herein, the non-breaching Party may, at its option, institute and prosecute proceedings in court to obtain damages for any breach of this Agreement, or to enforce the specific performance hereof or to enjoin the disclosure or unauthorized use of any of the Confidential Information, but nothing herein shall be construed to prevent such other legal remedies as the non-breaching Party may elect to invoke.
- 11.4 Acceptance of the terms contained in this Agreement shall not compel the Parties to enter into any further agreements or to proceed with any possible relationship or other agreements. Nothing in this agreement shall prevent the Parties to pursue other business opportunities, interconnection, access or special access arrangements or agreements in Belgium or abroad, either independently or with third parties, simultaneously with the discussions between the Parties or subsequently.
- 11.5 This Agreement shall be governed by Belgian law.
- 11.6 Any and all disputes concerning or arising out of the conclusion, interpretation or performance of this Agreement will be submitted exclusively to the courts of Brussels in Belgium.



1 **In witness whereof**, the Parties have caused this Agreement to be duly executed in the English language by their respective duly authorized officers, at the date(s) mentioned hereunder in two original copies, of which each Party acknowledges having received one copy.

For Belgacom

For Customer

By:

By:

Title:

Title:

Date: _____

Date: _____

By:

Title:

Date: _____

Annex Jc Specifications of the Tie Cables

Created on: 16 February 2012

belgacom





together
with



1 Table of contents

1	Table of contents.....	2
2	Tie cable for Type 1 services.	3
2.1	General Characteristics	3
2.1.1	Conductors	3
2.1.2	Insulation of the conductors.....	3
2.1.3	Outersheath.....	4
2.2	Cable assembly description.....	4
2.3	Particular characteristics	9
2.3.1	Insulation resistance.....	9
2.3.2	Diaphony between 2 pairs	10
3	Tie cable for Type 2 services.....	11
3.1	Description of the cable	11
3.2	Conductors.....	12
3.3	Electrical characteristics	12
3.3.1	Electrical requirements of the conductor	12
3.3.2	Insulating resistance.....	12
3.3.3	Dielectric strength.....	12
3.3.4	Cable impedance	12
3.3.5	Attenuation.....	13
3.3.6	Crosstalk between 2 pairs	13
3.3.7	Mutual capacitance	13
3.3.8	Capacitance unbalance	13
4	Tie cabling - Labelling	14
4.1	Raw Copper.....	14
4.1.1	Cable 24 pairs, OLO & BGC side	14
4.1.2	Cable 100p, OLO & BGC side	14
4.2	Shared Pair	14
4.2.1	BGC side	14
4.2.2	OLO & BGC side.....	14

2 Tie cable for Type 1 services.

2.1 General Characteristics

2.1.1 Conductors

- 2.1.1.1 mono-conductor tinned copper wires with a diameter as mentioned in the present technical specifications with a tolerance of minus 0.01 mm and plus 0.03 mm. In principle the conductors should be in one length.
- 2.1.1.2 The electrical resistance of the conductors. The specific electrical resistance of the conductor measured at 20°C shall be < 1/55 ohm or 0,01818 ohm/m/mm². The resistance per meter and per mm² increases with the temperature with 0,000068 ohm/°C.
- 2.1.1.3 The specific electrical resistance of the conductor measured at 20°C shall be < 1/55 ohm or 0,01818 ohm/m/mm². The resistance per meter and per mm² increases with the temperature with 0,000068 ohm/°C.
- 2.1.1.4 The conductors should be tinned completely smooth over the entire surface with minimum 2 g/m².

2.1.2 Insulation of the conductors

2.1.2.1 Insulation material :

- a. Cables up to 10 pairs : polyethylene (PE)

The conductor should be centred completely in its insulation. The thickness should be even and free from blots, holes, cracks, porous spots or any other defects. The insulation should not adhere to the conductors. The surface should be smooth and the colour stable. The colours should comply with the colours published in the International Electromechanical Committee, Publication 304 – latest edition.

- b. Cables as from 20 pairs on : insulation material of flame retardant polyethylene copolymer (FRPE)

Characteristics as per 2.1.a.

- 2.1.2.1 The PE and FRPE sheaths have a thickness of minimum 0,15 mm. This requirement is valid at any place of the sheath. The diameter of the insulated conductor should not exceed the diameter for this conductor, measured on the tinned copper with 0.6 mm.

2.1.3 Outersheath

2.1.3.1 The cable core is covered with an outersheath of polyethylene copolymer (FRPE).

2.1.3.2 He should be well centred and free from blasts, holes, and cracks, porous spots or any other defects.
The surface should be smooth and equal over the whole length.

up to 10 pairs (F1) : light grey RAL 7032

20 pairs and more (F2) : dark grey RAL 7001

2.1.3.3 The FRPE-sheaths should have following minimum thickness

<u>Number of conductors</u>				<u>Minimum thickness</u>
up to	21			0,8 mm
from	22	to	55	1,0 mm
from	56	to	101	1,2 mm
from	102	to	175	1,4 mm
from	176	to	250	1,6 mm
from	251	to	350	1,8 mm
from	351	to	450	2,0 mm
from	451	to	808	2,2 mm

2.2 Cable assembly description

2.2.1 The cables consist of tinned copper conductors with a diameter of 0,6 mm for the cable with 2 pairs and 0,5 mm for the cables with more than 2 pairs, insulated with PE for cables up to 10 pairs and FRPE for cables as from 20 pairs on.

The conductors are twisted together with a lay of maximum 75 mm.

In order to avoid cross talk the lay of adjacent pairs should slightly deviate from each other.

The pairs will be stranded in concentric layers.

The wires are either mono- or bi-coloured.

The cable core is wrapped in a spiral way with an Alu-PET foil having an overlay of min. 20 %.

The thickness of the Alu will be 25 micron. For cable with two pairs the Alu-PET foil can be placed in a longitudinal way.



together
with



2.2.2 The colours of the wires are as follows:

<u>Pair</u>	<u>a-wire</u>	<u>b-wire</u>
1	white	blue
2	white	orange
3	white	green
4	white	brown
5	white	grey
6	red	blue
7	red	orange
8	red	green
9	red	brown
10	red	grey
11	black	blue
12	black	orange
13	black	green
14	black	brown
15	black	grey
16	yellow	blue
17	yellow	orange
18	yellow	green
19	yellow	brown
20	yellow	grey
21	white-blue	blue



together
with



22	white-blue	orange
23	white-blue	green
24	white-blue	brown
25	white-blue	grey
26	red-blue	blue
27	red-blue	orange
28	red-blue	green
29	red-blue	brown
30	red-blue	grey
31	blue-black	blue
32	blue-black	orange
33	blue-black	green
34	blue-black	brown
35	blue-black	grey
36	yellow-blue	blue
37	yellow-blue	orange
38	yellow-blue	green
39	yellow-blue	brown
40	yellow-blue	grey
41	white-orange	blue
42	white-orange	orange
43	white-orange	green
44	white-orange	brown
45	white-orange	grey
46	orange-red	blue
47	orange-red	orange



together
with



48	orange-red	green
49	orange-red	brown
50	orange-red	grey
51	orange-black	blue
52	orange-black	orange
53	orange-black	green
54	orange-black	brown
55	orange-black	grey
56	yellow-orange	blue
57	yellow-orange	orange
58	yellow-orange	green
59	yellow-orange	brown
60	yellow-orange	grey
61	white-green	blue
62	white-green	orange
63	white-green	green
64	white-green	brown
65	white-green	grey
66	red-green	blue
67	red-green	orange
68	red-green	green
69	red-green	brown
70	red-green	grey
71	green-black	blue
72	green-black	orange
73	green-black	green



together
with



74	green-black	brown
75	green-black	grey
76	yellow-green	blue
77	yellow-green	orange
78	yellow-green	green
79	yellow-green	brown
80	yellow-green	grey
81	white-brown	blue
82	white-brown	orange
83	white-brown	green
84	white-brown	brown
85	white-brown	grey
86	red-brown	blue
87	red-brown	orange
88	red-brown	green
89	red-brown	brown
90	red-brown	grey
91	black-brown	blue
92	black-brown	orange
93	black-brown	green
94	black-brown	brown
95	black-brown	grey
96	yellow-brown	blue
97	yellow-brown	orange
98	yellow-brown	green
99	yellow-brown	brown

- | | | |
|-----|--------------|------|
| 100 | yellow-brown | grey |
| 101 | white-grey | blue |
- 2.2.3 The cables with 8 conductors and more should also have a tinned conductor insulated with PE/FRPE of the same diameter as the other conductors and placed in parallel with the cable direction (drainwire).
- 2.2.4 The insulation of this drainwire is white with double black ringmarking :
 - distance between two colourings : 5 mm
 - distance between two double colourings : 17 mm
- 2.2.5 Cables with four conductors are twisted into starquads.
- 2.2.6 The four conductors have following colours :
 pair one : white and blue
 pair two : turquoise and violet
- 2.2.7 In this cable the drainwire is replaced by an enamelled copperwire of 0,4 mm measured on the copper and 0,42 mm measured on the lacquer.
- 2.2.8 This wire is put in the centre of the starquad.

2.3 Particular characteristics

2.3.1 Insulation resistance

The insulation resistance is measured with 500 volt direct current at a temperature of 20 ° C. The results are read after one minute.

2.3.1.1 Tests on finished cables

The conductors not being measured as well as the eventual metallic screenings are connected to earth.

The insulation resistance measured at 20 ° C, under these circumstances should not be less than 5000 meg.ohm.kilometer.

2.3.1.2 Tests on individual wires

The insulation resistance is measured with 500 volt direct current.

Take a few meters of the cable as testing sample. Take the wires separately and put them in water, first at a temperature of 20°C and then 40°C.

The insulation resistance between each conductor and the water is being measured after one hour in water for both temperatures. The insulation resistance should be at least 100 megohm.kilometer at 20°C and 10 megohm.kilometer at 40°C.

2.3.2 Diaphony between 2 pairs

The para- and tele-diaphony measured between 2 pairs, at their characteristic impedance, should be equal or above 48 dB at a signal of 1000 kHz.

3 Tie cable for Type 2 services.

3.1 Description of the cable

The cable is respectively made of:

- 3.1.1 24 symmetrical pairs, each of them having the following characteristics:
- 3.1.1.1 Conductor : a mono-conductor wire of 0.5 mm (± 0.01 mm) diameter made of annealed copper, single strand, circular in section.
 - 3.1.1.2 Insulation : a full polyvinyl chloride insulating or PE coat of 0.20 mm thickness (0.17 mm minimum) and with a nominal external diameter of 0.90 [+0.05 mm, -0.03 mm]. The insulation shall fit closely to the conductor, without adhering to it. The colours shall correspond with IEC 189-2 App. A and IEC 304.
 - 3.1.1.3 The cabling element is a pair of two insulated conductors designated wire A and wire B. Twisting pitch of the pair: 50mm maximum.
- 3.1.2 The 24 cabling elements shall be stranded in concentric layers. A binding tape (preferably consisting of non-hygroscopic material) shall be placed between successive layers. The sequence of elements is from the centre to the outside layer; the counting direction is clockwise and the same in each layer.
- 3.1.3 The core of the cable must be wrapped with a protective layer of non-hygroscopic material, wound helical or longitudinal lapping and consists of 1 or 2 tapes with overlap.
- 3.1.4 A tinned copper wire with the same dimensions as the conductor wires shall be included in the cable in continuous contact with the surface of the screening foil.
- 3.1.5 A screening foil consisting of a sandwich foil aluminium-insulated tape-aluminium with an aluminium thickness of 25 microns on both sides. The tape shall be applied longitudinally round the wrapped core with an overlap of 6 mm minimum.
- 3.1.6 A braid shield of tinned copper wires, forming a screen with a minimum coverage ratio of 50 %, placed around the elements from 1.1. to 1.5. The diameter of the single wires shall be between 0.10 mm and 0.20 mm. The woven shield shall comply with the electrical requirements for the transfer impedance and the mechanical strength.
- 3.1.7 A thread of non-hygroscopic material denoting company of manufacture, laid underneath the sheath.
- 3.1.8 A monochrome grey (RAL 7032, colored in the block) sheath in LSZH material enveloping the previous assembly. The sheath shall be applied to fit closely to the core of the cable without adhering to the screen or to the insulated conductors or to the wrapping tape. It shall be perfectly continuous and having a thickness as uniform as possible. Sheath thickness: 0.80 mm nominal, 0.60 mm minimum. The diameter of the finished cable shall not exceed 11,5 mm.

3.2 Conductors

- 3.2.1 Composition of the conductors: the conductors have to be made of a copper wire drawn in one piece for the whole manufacturing length. No soldered joint is tolerated.
- 3.2.2 Eccentricity : the eccentricity shall be maximum 1.8 at any cross section.
- 3.2.3 Conductor insulation: The insulation (polyvinyl chloride or PE) of the conductor shall have adequate mechanical strength and elasticity which remains sufficiently constant during normal use; it shall be continuous and of uniform thickness.
- 3.2.4 Sheath insulation: The insulation (LSZH) of the conductor shall have adequate mechanical strength and elasticity which remains sufficiently constant during normal use; it shall be continuous and of uniform thickness.

3.3 Electrical characteristics

The measurements to carry out in order to check the electrical features should always be carried out on cable sections of a nominal length of 250 meters, at a temperature comprised in between 15 and 25 degrees centigrade.

3.3.1 Electrical requirements of the conductor

The loop resistance shall be maximum 196.5 ohm/km at 20°C and the conductivity shall be minimum 57 m/ohm.mm² at 20°C.

3.3.2 Insulating resistance

The measurements will be taken after a minute of electrification. The insulating resistance between the two wires of the pair or between each wire and the screen won't be inferior to 500 Megohm x kilometer.

3.3.3 Dielectric strength

The dielectric strength shall be minimum 1500 Vac when measured during 1 minute.

3.3.4 Cable impedance

The typical cable impedance has to be in the range 100 ohms ± 10 ohms at 1 MHz. With any price offer for this cable, the supplier has to provide a document containing the variation curves of the real and imaginary parts of the typical characteristic of a section of 250 meters, in function of the frequency, in a transmission band opening the range of 0.3 to 10000 kHz. Indications on the manufacturing tolerances have to be added to the curves which will be of average values.

3.3.5 Attenuation

With every price offer for this cable, the supplier will communicate the kilometric attenuation value at $(20 \pm 2)^\circ\text{C}$ for the frequencies between 0.3 and 10000 kHz.

At 1 Mhz, the attenuation may not exceed 32 dB/km.

3.3.6 Crosstalk between 2 pairs

The supplier has to communicate the near end and far end crosstalk values at 100, 500, 1000 and 10000 kHz between two symmetrical pairs under the screen placed side by side on a length of 250 meters, each terminated on their cable impedance. This value has to be greater than 55 dB at 1 MHz and 40 dB at 10 MHz.

3.3.7 Mutual capacitance

The mutual capacitance shall be maximum 100 nF/km measured between 500 and 2000 Hz.

3.3.8 Capacitance unbalance

Between any pair and the earth the capacitance unbalance shall not exceed 750 pF/500m with the exception of 1 value of the values up to 1500 pF/500m at 1 kHz.

4 Tie cabling - Labelling

To guarantee an efficient operational work, each tie cable will be labelled as follows:

4.1 Raw Copper

4.1.1 Cable 24 pairs, OLO & BGC side

RC/A - Cooxx - 23/0/00 to 23/0/23 (xx) : OLO code
(numbering = column/bed/position)

4.1.2 Cable 100p, OLO & BGC side

RC - Cooxx - 23/5/00 to 23/5/99 (xx) : OLO code
(numbering = column/bed/position)

4.2 Shared Pair

4.2.1 BGC side

side "LINE" : SPL 0098/0001 to 0098/0024
side "POTS" : SPL 0098/0051 to 0098/0074
(numbering = upright/position)

4.2.2 OLO & BGC side

side "DATA" : Cooxx 61/01 SPL DATA 1-3 P (P for PSTN)
Cooxx 61/01 SPL DATA 1-3 I (I for ISDN)
(numbering = rack/subrack)

Annex Jd Current Raw Copper Type 1

Pair Selection Process

Created on: 16 February 2012

belgacom

together with



1 Table of contents

1 Table of contents.....2

Current Raw Copper Type1 Pair Selection Process

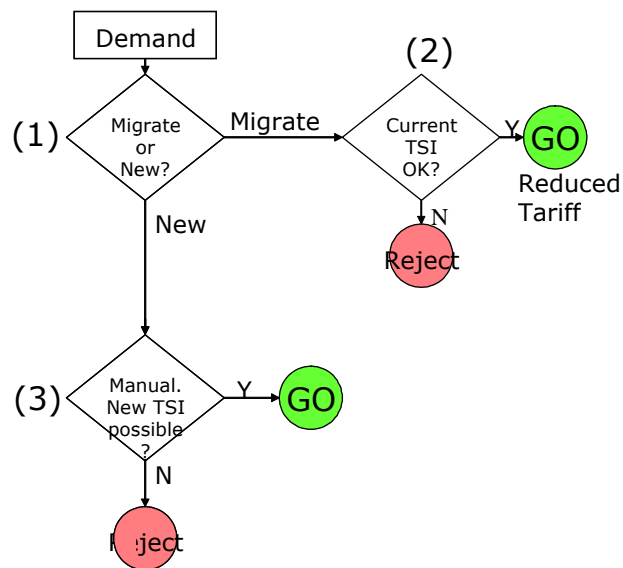

- (1) The OLO has the choice to introduce a demand for 'migrate' or 'new'. In case 'migrate' is possible a reduced installation tariff will be applied, as no truck roll out is necessary for re-jumpering at a lower level than the MDF.
- (2) Check if the current technical situation (TSI) of the 'active' line, the OLO wants take over, can be used 'as such', i.e. fulfils all 'pair selection criteria'
 - 'pair selection criteria'**
 - **service availability:** the service is possible at the concerned MDF.
 - **pair continuity:** a full metallic pair exists between MDF and end customer
 - **pair position in the cable:** no special requirements
 - **service compatibility:** migrate possible for PSTN/ISDN lines and other Belgacom Services (e.g. LL, ...)
 - **length:** No criteria for length
- (3) Search for a new technical situation (TSI), that fulfils all pair 'selection criteria' (see above) and can be realised by intervention of an electrician, i.e. by re-jumpering of the concerned user pair in a distribution frame (either in Customer Premises, street cabinet, LDC, MDF).

Details of current pair selection criteria for Type1:

- 1) Service availability
 - OLO has Type1 facilities at the concerned MDF and a free block position is transferred to BGC.
- 2) Pair continuity:
 - No Pair Gain System or filter (for 1+1) on the line, neither loading coils
- 3) Pair position in the cable:
 - No special requirements
- 4) Service compatibility, e.g.:
 - No DOVE line
 - No pay-phone infrastructure on this line
 - TSI is not a service-line
 - Only on single telephony line (no PBX, MSN number, DID, maintenance line, ...) or other Belgacom Service (e.g. LL, ...)
 - no reserved positions in TSI (i.e. other demand ongoing)

General remark:

A manual process is currently implemented. Automation will be foreseen if volumes justify cost.

Annex Je Current Raw Copper Type 2

Pair Selection Process

Created on: 16 February 2012

belgacom



1 Table of contents

1	Table of contents.....	2
----------	-------------------------------	----------

Current Raw Copper- Type2 Pair Selection Process

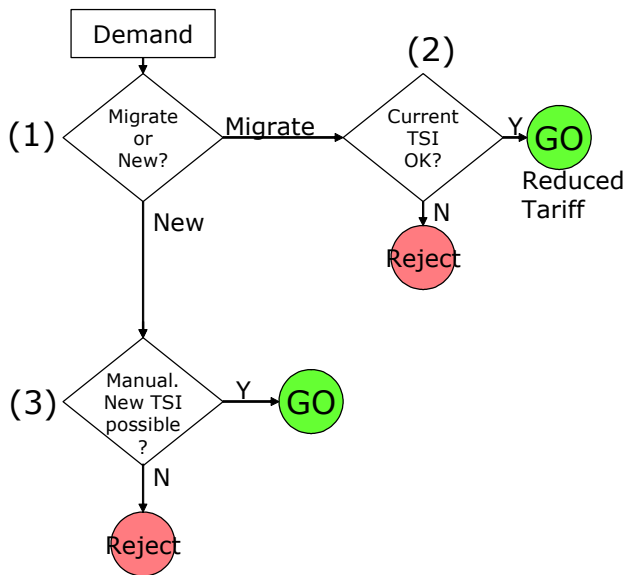

- (1) The OLO has the choice to introduce a demand for 'migrate' or 'new'. In case 'migrate' is possible a reduced installation tariff will be applied, as no truck roll out is necessary for re-jumpering at a lower level than the MDF.
- (2) Check if the current technical situation (TSI) of the 'active' line, the OLO wants take over, can be used 'as such', i.e. fulfils all 'pair selection criteria'
 - **service availability**: the service (RC-TYPE1) is possible at the concerned MDF.
 - **pair continuity**: a full metallic pair exists between MDF and end customer
 - **pair position in the cable**: application of pair selection rules
 - **service compatibility**: migrate possible for PSTN/ISDN lines and other Belgacom Services (e.g. LL, ...)
 - **length**: No criteria for length
- (3) Search for a new technical situation (TSI), that fulfils all pair 'selection criteria' (see above) and can be realised by intervention of an electrician, i.e. by re-jumpering of the concerned user pair in a distribution frame (either in Customer Premises, street cabinet, LDC, MDF).

Details of current pair selection criteria for RC-Type2:

- 1) Service availability:
 - OLO has RC-Type1 facilities at the concerned MDF and a free block position is transferred to BGC.
- 2) Pair continuity:
 - No Pair Gain System or filter (for 1+1) on the line, neither loading coils
- 3) Pair position in the cable:
 - No HS Transmission line(2Mbit) in same quad or in quad +1/-1
- 4) Service compatibility, e.g.::
 - No DOVE line
 - No pay-phone infrastructure on this line
 - TSI is not a service-line
 - Only on single telephony line (no PBX, MSN number, DID, maintenance line, ...) or other Belgacom Service (e.g. LL, ...)
 - no reserved positions in TSI (i.e. other demand ongoing)

General remark:

A manual process is currently implemented.

Automation will be foreseen if volumes justify cost.

Annex Jf Shared Pair

Pair Selection Process

Created on: 16 February 2012

belgacom



1 Table of contents

1	Table of contents.....	2
----------	-------------------------------	----------

Shared Pair Pair Selection Process

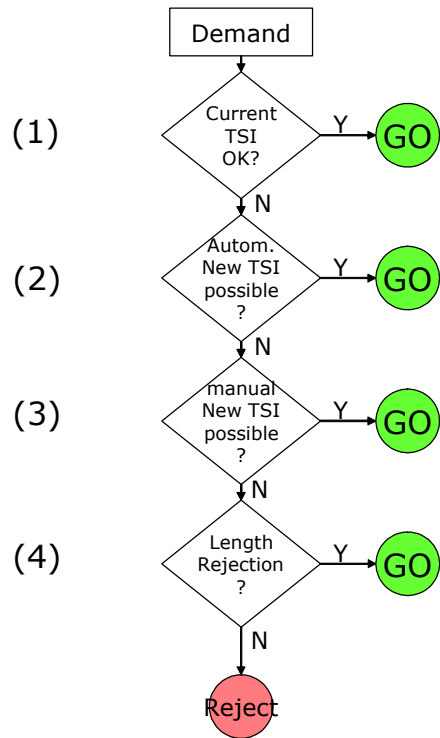

- (1) Automatic check if current technical situation (TSI) of the PSTN/ISDN line, on which the OLO asks Shared Pair (SP), can be used 'as such', i.e. fulfils all 'pair selection criteria'.
'pair selection criteria':
 - **service availability:** the service (Shared Pair) is possible at the concerned MDF.
 - **pair continuity:** a full metallic pair exists between MDF and end customer
 - **pair position in the cable:** application of pair selection rules
 - **service compatibility:** Shared pair is only possible on simple PSTN/ISDN lines
 - **length:** criteria of length as defined by BGC to ensure QoS

- (2) Automatic search for a new technical situation (TSI), that fulfils all pair 'selection criteria' (see above) and can be realised by intervention of an electrician, i.e. by re-jumpering of the concerned end customer pair in a distribution frame (either in Customer Premises, street cabinet, LDC, MDF).

- (3) The automatic pair selection processes may have either not been possible or did not succeed.
 - Not possible: when an infrastructure project work (e.g. due to road works, network extension, ...) is ongoing on a cable, KVD,... the automatic pair selection process is blocked and pairs can only be assigned by the (local) Network Planning Services, responsible for these works
 - Not succeeded: When the (simple) rules of the automated pair selection process were not able to cope with the network complexity, a manual assignment is tried, using the same principles for pair selection as in the automatic case (see (1) & (2)).
 Remark: Extra manpower and process time is needed, which may be several days, when (local) Network Planning Services need to intervene.

- (4) If only reason for reject is line length, this rejection will be overruled.

Details of current pair selection criteria for Shared Pair:

- 1) Service availability:
 - OLO has SP facilities at the concerned MDF and a free, appropriate (PSTN or ISDN) splitter position is transferred to BGC.

- 2) Pair continuity:
 - No Pair Gain System or filter (for 1+1) on the line, neither loading coils
 - no bridged taps

- 3) Pair position in the cable:
 - No HS Transmission line(2Mbit) in same quad or in quad +1/-1

- 4) Service compatibility, e.g.:
 - No 16kHz taxation pulse on the line
 - No DOVE line
 - No pay-phone infrastructure on this line
 - TSI is not a service-line
 - Only on single telephony line (no PBX, MSN number, DID, maintenance line, ...)- no reserved positions in TSI (i.e. other demand ongoing)

- 5) Length check:
 - normal BGC rules will be overruled by step (4)

General remark:

The automatic part of the process is currently being implemented.



Annex Jg Characteristics of Cabling

Created on: 16 February 2012

belgacom



1 Table of contents

1	Table of contents.....	2
2	Transmission properties of the access network.....	3
2.1	<i>Generalities.....</i>	3
2.2	<i>Physical characteristics of the cables.....</i>	3
2.3	<i>Electrical characteristics of the cables.....</i>	4

2 Transmission properties of the access network

2.1 Generalities

- 1 A subscriber loop consists of sections of twisted pairs cables of different gauges. All the sections are buried and connected together by means of electrical joints, called splices, directly placed in the ground or sometimes in a manhole.
- 2 In the ideal situation, the Access Network has a star configuration with the feeder cable bundles going from the main distribution frame to the street cabinet. From the street cabinet, via distribution cables and drop wires, the wire pairs are terminated at the NTP (Network Termination Point) in the individual customer sites. The reality shows that cable arrangements leads sometimes to a meshed structure in the feeding network.
- 3 Each telecom cable consists of a number of copper conductors grouped in quads; these quads can be arranged in bundles or in layers, depending on the type of cable.

2.2 Physical characteristics of the cables

- 4 A conductor can be isolated by a layer of paper (in the old generation cables) or synthetic material, usually polyethylene.
- 5 Most of the conductors have a 0.5 mm or 0.6 mm diameter; distant customers however needs to be connected via conductors of 0.8 and 1.0 mm; 2000 pairs cables going out of the central office are sometimes made of 0.4 mm conductors.
- 6 In paper insulated cables, the conductors are surrounded by a lead sheath, generally protected by armouring and polyethylene sheath.
- 7 In plastic insulated cables used in the distribution network, the conductors are surrounded by a polyethylene sheath.
- 8 In plastic insulated cables used in the feeding network, the conductors are surrounded by an aluminium screen, a polyethylene internal sheath, an armouring and a polyethylene external sheath.
- 9 The plastic cables are in the majority of the cases longitudinally waterproof.

2.3 *Electrical characteristics of the cables*

- 10 The table below gives some typical characteristics of the access network cables [figures given by the cable manufacturers or by measurements in the field]

Diameter	LR	KC	A800	A40.000	A150.000	A300.000
0.4 mm	275	55	2.0	7.5	11.5	14.5
0.5 mm	180	50-55	1.3	6	9	11
0.6 mm	123	38.5-46	1.0	4	6	8
0.8 mm	69	38.5	0.7	2.5	4	5.5

LR = Loop Resistance in ohm/km

KC = average Kilometric Capacity in nF/km (it depends on the type of cable)

A800 = Attenuation measured at 800 Hz in dB/km

A40.000 = Attenuation measured at 40.000 Hz in dB/km

A150.000 = Attenuation measured at 150.000 Hz in dB/km

A300.000 = Attenuation measured at 300.000 Hz in dB/km

- 11 NB: the attenuation values are conditional. The reader must note that these figures are given for cable. A loop is made of several pieces of cables and then additional attenuation and reflections due to the splices and the different cable gauges will occur.
- 12 For the insulation resistance between the 'a' and 'b' wires of a pair (without terminal equipment) or between wire and earth, reference is made to Annex C : Technical Specifications.

Annex Jh KVD-Streets Information

Created on: 16 February 2012

belgacom

together with



1 Table of contents

1	Table of contents.....	2
2	KVD-Streets Information.....	3

2 KVD-Streets Information

- 1 The Beneficiary can request an inquiry to obtain the streets that depend on a KVD. His requests can be sent by e-mail to the Belgacom Customer Service for LLU
- 2 (e-mail: car.llu@belgacom.be).
- 3 A request can include 1 or more KVD numbers + network name.
- 4 Depending on the extent of the request, the average response time for 10 KVD's for example is targeted at +- 3 working days. The inquiry results will be replied to by e-mail.
- 5 Pricing information for the KVD-Streets Information is listed in Annex H.
- 6 Service start will be communicated.

Annex K

Migrations to BRUO, BROBA and WBA

Created on: 16 February 2012

belgacom

together with



1 Table of Content

1	Table of Content.....	1
2	Definition	2
2.1	General	2
3	Single line migrations	4
3.1	Definition.....	4
3.2	Scenarios	4
3.3	Ordering and implementation	4
4	Project-Based Migrations.....	6
4.1	Definition.....	6
4.2	Scenarios	6
4.3	Ordering and implementation	6
5	Mass Migrations.....	8
5.1	Definition.....	8
5.2	Scenarios	8
5.3	Ordering and implementation	9
5.4	Initiation Phase.....	9
5.5	Forecast procedure	9
46.	The confirmed volume after repartition will be considered as the binding forecast volume of the first forecasted month.	10
5.6	Preparation phase.....	10
5.7	Installation Phase	11
59.	The SLA repair conditions start as from this documentation date. Before this date, repairs are done on a best effort basis.	11
5.8	Evaluation Phase.....	11
6	Migrations Repartition Rules	12
	Appendix (a) Letter of Information	13

2 Definition

1. A migration to BRUO, BROBA or WBA is a replacement of an initial service by a BRUO, BROBA or WBA service, either initiated by an End-User request or action, or by a Beneficiary requests to Belgacom to cancel an initial solution in order to bring into service a new one of BRUO, BROBA or WBA. The initial solution may be either a mass market service, or corporate solution (e.g. Leased Line, VPN, SDSL, etc.); a Belgacom service or that of another Beneficiary, a BROBA, a BRUO, or a WBA service of the same or another Beneficiary. The migration includes the coordination by Belgacom of the administrative and technical management of the demand targeting a minimal interruption of the service delivered to the End-User.
2. There are three (3) types of migrations:
 - a) the Single Line Migrations
 - b) the Mass Migrations
 - c) the Project-Based Migrations

2.1 General

3. Migrations by which the End-User doesn't change of operator whilst the End-User has a service including Belgacom voice, will be executed after the Beneficiary has informed the End-User regarding the consequences of the performance of the migration service. Belgacom will, at all times, be allowed to request a copy of the Letter of Information sent out to a specific End-User in case of End user complaint. If requested by Belgacom, the Beneficiary will forward such copy to Belgacom within a delay of three (3) working days. A template of Letter of Information is attached in Appendix a) to the present Annex. The possibility for Belgacom to request a Letter of Information is limited to a period of six (6) months starting from the effective migration. When such a migration concerns business/corporate solutions, Belgacom advises to handle this type of migration as a Project-Based Migration.
4. The Beneficiary will be responsible for dealing with claims for damages or penalties issued by the End-User as a result of the migration, including its impact on the performance of the voice service or the interruption of this service. Belgacom shall not be held liable for damage resulting from the performance of the migration service and particularly from the interruption of the voice service if any as a consequence of the performance of the migration service requested by the Beneficiary, unless this damage is due to a fault by Belgacom. Where applicable, the Beneficiary will indemnify Belgacom for damage as a result of the migration, including its impact on the performance of the voice service or the interruption of this service, unless where this damage is due to a fault by Belgacom.
5. There are many possible migration scenarios. Belgacom will develop standard processes for a specific type of Single Line or Mass Migration under the following conditions:
 - a) There is a significant number of orders per month for this specific scenario, i.e. 250 orders/month over the past 3 months, that are currently treated manually or
 - b) Beneficiary provides binding forecasts of a specific Single Line or Mass migration scenario with a minimum of 250 orders/month over a minimal period of 3 months
6. Other scenarios will be treated as Project-based Migration processes.
7. Once the process has been developed by Belgacom for a specific migration scenario, Belgacom will maintain this scenario as long as the conditions described above are fulfilled. If not, Belgacom reserves the right to adapt its procedures and accordingly, Belgacom cannot guarantee that the said processes will be further maintained.
8. In case Belgacom needs to develop (or re-develop) a specific migration scenario under the above conditions, Belgacom will analyze and undertake such development in the best possible implementation timeframe and in negotiation with the Beneficiaries. In that case, Belgacom will inform the market of the planning and updates of the development. The IT developments for a new process will generally take 6 months, unless investigation of the requested development concludes otherwise.

9. For Migrations scenarios for which no specific process is developed, the Beneficiary will send Belgacom a deactivation request for the old service and an activation request for the new service. The Beneficiary is responsible for the coordination of the execution of the deactivation and activation requests.

3 Single line migrations

3.1 Definition

10. Single Line Migrations are migrations ordered by the Beneficiary or initiated by an End-User request in a non planned way, i.e. without being organized in the framework of a project. Single Line Migrations are thus a direct or indirect result of a demand or action of the User. The action of the Users can be:
 - a) User requesting to migrate from the initial service of Beneficiary 1 to a BRUO/BROBA/WBA service of Beneficiary 2. Also called Transfer
 - b) User asking to modify its Belgacom voice service while the Beneficiary delivers a data service to the User, this will result in a modification of the type of line (e.g. Shared Pair ⇔ Raw Copper plus, BROBA ADSL with voice ⇔ BROBA without voice, WBA VDSL2 with voice ⇔ WBA VDSL2 without voice). Also called Auto-Convert
 - c) Beneficiary initiated case by case migrations on a non-project basis.

3.2 Scenarios

11. The following Single Line migration scenarios are currently supported ; the specifications for ordering are published on the web on the personal page of BRUO, BROBA, and WBA:
 - a) Belgacom Retail ADSL to BROBA II ADSL with voice
 - b) Belgacom Retail ADSL to BROBA II ADSL without voice
 - c) Belgacom Retail ADSL to BRUO Shared Pair
 - d) Belgacom Retail ADSL to BRUO Raw Copper
 - e) Belgacom Retail ADSL to WBA VDSL2 with voice
 - f) Belgacom Retail ADSL to WBA VDSL2 without voice
 - g) Belgacom Carrier DSL with voice to BROBA II ADSL with voice
 - h) Belgacom Carrier DSL with voice to BRUO Shared Pair
 - i) Belgacom Carrier DSL with voice to WBA VDSL2 with voice
Belgacom Carrier DSL without voice to WBA VDSL2 without voice
 - j) Belgacom Carrier SDSL to BROBA SDSL
 - k) BROBA II ADSL with voice to BRUO Shared Pair
 - l) BROBA II ADSL with voice to WBA VDSL2 with voice
 - m) BROBA II ADSL with voice to BROBA II ADSL without voice
 - n) BRUO Shared Pair to BRUO Raw Copper plus
 - o) BRUO Shared Pair to BRUO Raw Copper
 - p) BRUO Raw Copper plus to BRUO Raw Copper
 - q) BRUO Shared Pair to WBA VDSL2 with voice
 - r) BRUO Raw Copper plus to WBA VDSL2 without voice
 - s) BRUO Raw Copper to WBA VDSL2 without voice
 - t) BROBA II ADSL without voice to BRUO Raw Copper
 - u) BROBA II ADSL without voice to WBA VDSL2 without voice
 - v) BROBA II SDSL to WBA VDSL2 without voice

3.3 Ordering and implementation

12. The same rules for the order processing of the provisioning processes in BRUO/BROBA/WBA are followed for the respective target products.

13. The customer service LLU (CSE/LLU) checks the messages and in particular if the following information is correctly communicated:
 - Access line presence / codification number
 - Other checks will be performed by the customer service in case of migration from Belgacom ADSL / SDSL / VDSL2 retail or wholesale:
 - o An ADSL / SDSL / VDSL2 service must be present on the line
 - o No pending order may be present on the line
 - o etc.
14. Orders not validated will be rejected.
15. On the date complying with the basic BROBA/BRUO/WBA SLA or on a date agreed upon between Belgacom and the Beneficiary, the physical initial situation is cancelled and the new one is brought into service.
16. The processes defined in accordance with the above, tend to minimize the duration of the interruption of service. The targeted duration of interruption of service is maximum 40 minutes.
17. Belgacom will perform all actions of the deactivation process of the initial product. Beneficiary is informed of the migration (via the DONE messages) at the latest on execution day + 1 half working day.
18. The documentation in the Belgacom legacy systems is adapted on execution day + 2 working days.
19. The SLA repair conditions start from the date mentioned in paragraph 18 here-above. Before this date, repairs are done on a best effort basis, until further study of Belgacom.

4 Project-Based Migrations

4.1 Definition

20. Project-Based Migrations are migrations realized in the framework of an Agreement between Belgacom and the Beneficiary where the Beneficiary wants a specific coordination of the execution by Belgacom. In such case, Belgacom and Beneficiary will enter into a Project Management Agreement that will define the specific requirements, the planning and the related costs for these Project-Based Migrations. This agreement will describe several aspects of the project like the date of realization, the number of migrations to perform over a certain period, the concerned LEX's, the concerned services, the content and use of a migration list and in general all relevant information needed to ensure an optimal realization of the migrations.
21. Project-Based Migrations are:
 - migrations scenarios that can not be qualified as Single Line Migrations as here-
above defined, e.g. migrations that do not result of an end-user request, or
 - complex migrations from an initial corporate solution e.g. from a Leased Line product, it is strongly advised, to limit the risk of lengthy interruption of service, to implement working procedures using spare copper pairs when available. The migration will be done by bringing into service a spare copper pair before the deactivation of the existing service, or
 - migrations that do not have the standard criteria of Mass Migrations.

4.2 Scenarios

22. All Migration scenarios that are not covered by the standard Single Line Migrations nor Mass Migrations can be treated on a case-by-case approach through Project-Based Migrations.

4.3 Ordering and implementation

23. The request for project-based migration is communicated by the Beneficiary to Belgacom via their respective SPOC's, i.e. on the Belgacom side, the SPOC will be the Beneficiary's account manager.
24. The Account Manager (AM) collects the basic information about the migration project: migration type, geographical needs, timing, etc.
25. Representatives from Belgacom and from the Beneficiary set up common agreed migration rules and planning.
26. The format and methods of the Project-Based Migrations will vary depending on the case-by-case agreed procedures between Belgacom and Beneficiary or depending of the systems and methods used at that moment.

27. A final Go/No Go for execution is given by the Beneficiary at the end of the Preparation Phase, which gives the opportunity to cancel or amend the migration of any given line. There are no roll-back, no amend nor cancellation possibilities during the installation phase.

28. The repair will follow the normal repair process.

5 Mass Migrations

5.1 Definition

29. Mass Migrations are migrations ordered by the Beneficiary in a planned way and realized in the framework of a standard monthly procedure defined for all the Beneficiaries willing to realize Mass Migrations.
30. There are two categories of Mass Migrations:
 - a) *Physical Migration*: Intervention by technician needed on DSLAM or in local network
 - b) *Virtual migration*: No intervention by technician needed on DSLAM or in local network.
31. Mass Migrations require a binding forecast for minimum quantities of 250 lines per month (with the possibility to mix different mass migration scenarios). Additionally, Physical Mass Migrations require at least 10 lines in the same LEX (or LDC or other) at the same time, and maximum 40 lines per day.
32. In all other cases, the migrations will be executed as Single Line Migrations or Project-Based Migrations.

5.2 Scenarios

33. The following mass migration scenarios are currently supported:
 - a) Mass Virtual Migration from Carrier DSL with voice to BROBA II ADSL with voice
 - b) Mass Physical Migration from Carrier DSL with voice to BROBA II ADSL with voice
 - c) Mass Physical Migration from Carrier DSL with voice to BRUO Shared Pair
 - d) Mass Physical Migration from Carrier DSL without voice to BROBA II ADSL without voice
 - e) Mass Physical Migration from BROBA II ADSL with voice to BRUO Shared Pair
 - f) Mass Physical Migration from BROBA II ADSL without voice to BRUO Raw Copper
 - g) Mass Physical Migration from BRUO Raw Copper plus to BRUO Raw Copper
34. Process flows of the above-mentioned scenarios are available at the Belgacom Carrier and Wholesale secured website.

5.3 Ordering and implementation

35. This procedure will describe the following phases of the process:
- Initiation phase
 - Forecast phase
 - Preparation phase
 - Installation phase
 - Evaluation phase
36. The format and methods of the Mass Migrations will vary depending on the agreed procedures between Belgacom and Beneficiary or depending of the systems and methods used at that moment.

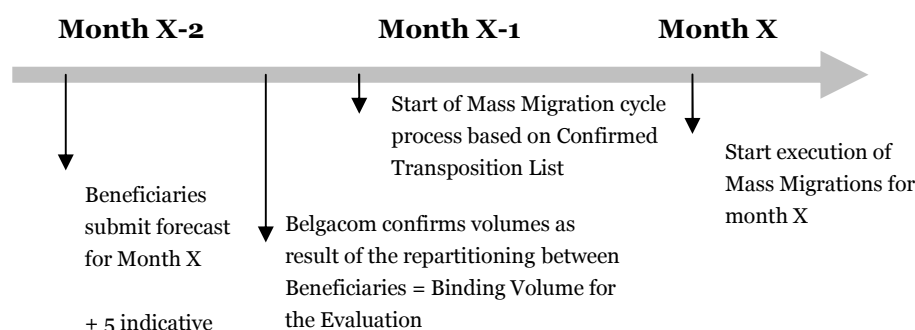

5.4 Initiation Phase

37. The request for mass migration is communicated by the Beneficiary to Belgacom via their respective SPOC's, i.e. on the Belgacom side, the SPOC will be the Beneficiary's account manager.
38. The Account Manager (AM) collects the basic information about the mass migration and the forecast.

5.5 Forecast procedure

39. In the framework of Mass Migrations Belgacom requests a rolling forecasts of 6 months. The forecast for the first month will be used to confirm, after repartition, the binding volume for that month. The forecast for the five (5) subsequent months are indicative and will be used as input to mid term planning.
40. The monthly forecast has to be sent to the Beneficiary's Account Manager, two (2) months in advance of the month of the effective migrations, i.e. two (2) months before the migrations take place, and this on the first (1st) working day of every month.
41. The first month of the rolling forecast must be expressed in number of End Users and will be detailed per LEX (the Beneficiary submits per LEX, but the forecast is only binding for the total of a subarea). The Beneficiary is requested to prioritize its LEX's from high priority to low. For the subsequent months the beneficiary indicates the mass migration volume that he plans by mass migration scenario.

42. In order to top up the migration volume, the Beneficiary can give a back-up list of Lex's to migrate to replace some LEX's that for a reason or an other can not be taken into consideration for migration during that month.
43. In case the Mass Migrations will last several months, only the number of migrations to be executed two (2) months later will be taken into consideration for the repartition rule.
44. Belgacom will analyse internally the received forecasts and:
 - a. Compare the work concentration. Ex: requests of all Beneficiaries on same LEX at same time is not possible
 - b. Verify the available resources and outsourcing capacities in the sub area
 - c. Verify the systems and support the mass migration volumes
 - d. Apply the repartition rule of the Mass Migrations capacity between the Beneficiaries.
45. Within 1 week after the forecast intake date, in case of overbooking of the available Mass Migrations volume, Belgacom will communicate the result of the repartition by confirming the maximum mass migration volumes to each Beneficiary.
46. The confirmed volume after repartition will be considered as the binding forecast volume of the first forecasted month.

5.6 Preparation phase

47. Representatives from Belgacom and from the Beneficiary set up the Transposition list, also called the migration list, and the planning.
48. Within 3 weeks after the forecast intake date, based on the analyses, Belgacom will communicate the Initial Transposition List with all End-User lines details needed to perform the migrations in the form of a template and will commit to execute the communicated volume.
49. Beneficiary analyses, adapts and completes the Initial Transposition List in order to deliver a Confirmed Transposition List to Belgacom for execution.
50. If a specific LEX, that is part of the Mass Migrations of a specific month, can only be migrated for a part, where Beneficiary requested to do this in one month (when physically feasible), the Beneficiary may, without any consequences, request to replace the Mass Migrations for this specific LEX by the Mass Migrations of one of the Beneficiary's back-up LEX's. This has to be done within one week after Belgacom confirms the volumes of that month.
51. A final Go/No Go for execution is given by the Beneficiary at the end of the Preparation Phase, which gives the last opportunity to change the transposition list.

5.7 Installation Phase

52. There is no roll-back, no amend due date nor Beneficiary cancel possibilities as soon as the installation phase is started.
53. The physical initial situation is suppressed and the new one is realized.
54. Belgacom will establish processes to minimize the interruption duration. The targeted duration of interruption of service is 40 minutes.
55. Belgacom will perform all actions of the deactivation process of the initial product.
56. The documentation in the Belgacom legacy systems is adapted on the execution date + 2 working days.
57. The Beneficiary is informed line per line that the migrations is done and this through a 'Done' xml.
58. The standard repair process will be active the day after the 'Done' date, i.e; as from the Done date + 1 working day, when the documentation has been updated.
59. The SLA repair conditions start as from this documentation date. Before this date, repairs are done on a best effort basis.

5.8 Evaluation Phase

60. The volume that Belgacom confirmed after the market repartition versus the realized Mass Migrations will be used as the reference to see if the commitment was met.
61. On the Confirmed Transposition List of the Beneficiary, a negative deviation of 15% per sub area on the confirmed forecast (with a maximum of 400 lines per sub area) is allowed per Beneficiary.
62. Positive deviations are always allowed, i.e. in case Belgacom and the Beneficiary agree to perform more lines as initially forecasted by the Beneficiary. These migrations are executed on a best effort base.
63. Mass Migration fees¹ are due in case of non respect of binding forecast while Belgacom could not reallocate the resources; this means that if Belgacom can re-allocate, there is no fee due, even when the binding forecast was not respected. The re-allocation is applicable for all services when similar actions can be executed by the Belgacom personnel without additional training.
64. In case the Mass Migrations process is stopped by the Beneficiary, because the Beneficiary cannot provision customers due to Belgacom, the Mass Migration fee is not applicable.

¹ See BRUO Annex H Price List or BROBA Annex 6: Pricing and Billing

6 Migrations Repartition Rules

65. The Migrations Repartition Rules are defined in order to aim for a transparent repartition of the available Migrations capacity of Belgacom between the requesting Beneficiaries.
66. Since the Single Line Migrations have their own forecast procedure and as they can be considered as part of the day-by-day capacity planning of the business based on End-User requests, they will not be taken into account for the repartition exercise.
67. On the other hand, Project Migrations and Mass Migrations, being both a Beneficiary request for network optimisation, need to be considered together in the framework of case-by-case planning.
68. That maximum volume of these 'case' migrations per month is calculated fairly based on the market needs and in accordance with the resources available.
69. The sum of the Project-Based Migrations and the Mass Migrations will be limited to a maximum of 12.000 migrations per month for all Beneficiaries of BRUO, BROBA and WBA. With a maximum of 7.000 Physical Migrations, that requires a manual handling by Belgacom.
70. For mass migration also a nationwide spread of the physical migration capacity must be observed.
71. The maximum volume of Mass Migrations will be determined and definitely fixed at least 2 months before the migrations based on the migrations forecasts.
72. Summarized, the repartition rule will follow the following script on a monthly basis:
 - a) Migrations include:
 - a. Mass Migrations (MM)
 - b. Project-Based migrations (PBM)
 - b) Maximum 12.000 Migrations / month for all Beneficiaries, from which maximum 7.000 Physical Migrations
 - c) Every Beneficiary has right to an equal part: $((12.000)/\# \text{ of Beneficiaries})$
 - d) The capacity not used by other Beneficiaries can be used equally by the others if there forecasted volume has not been reached yet.

Appendix (a) Letter of Information

Cher Client,

Le [date], une intervention sur votre connexion sera effectuée qui provoquera une interruption de votre service pendant une période que nous veillerons à écourter au maximum.

A l'occasion de cette opération, votre ligne téléphonique sera également affectée pendant un temps que nous espérons aussi court que possible.

Si vous deviez avoir des questions à ce sujet, n'hésitez pas à prendre contact avec notre helpdesk [n° OLO].

Nous vous prions de nous excuser pour l'inconvénient causé et ...

Geachte Klant,

Op [date], zal een interventie aan uw verbinding uitgevoerd worden, die een tijdelijk service-onderbreking zal teweeg brengen, die wij tot een minimum zullen beperken.

Ter gelegenheid van deze operatie zal uw telefoonaansluiting hier eveneens invloed van ondervinden gedurende een tijdspanne, die wij zo kort mogelijk hopen te houden.

Onze helpdesk staat uiteraard tot uw dienst (N° OLO) voor alle vragen, die u zich in dit verband zou stellen.

Wij verzoeken u ons te willen verontschuldigen voor dit kortstondig ongemak...