



**INSTITUT BELGE DES SERVICES POSTAUX
ET DES TÉLÉCOMMUNICATIONS**

**PROJET DE DÉCISION DU CONSEIL DE L'IBPT
DU 15 MAI 2012
CONCERNANT
L'OFFRE DE RÉFÉRENCE SUR L'ALTERNATIVE MULTICAST**

Méthode d'envoi des réactions au présent document

Délai de réponse: 14 juin 2012

Personne de contact : Thomas Gille, Ingénieur-conseiller (02 226 88 55)

Adresse de réponse par e-mail: thomas.gille@ibpt.be

Les réponses sont attendues uniquement par voie électronique.

Le document doit indiquer clairement ce qui est confidentiel.

Sommaire

| | | |
|-----------|---|-----------|
| 1. | INTRODUCTION | 3 |
| 2 | PROCÉDURE | 4 |
| 2.1 | DÉROULEMENT DE LA PROCÉDURE..... | 4 |
| 2.2 | CONSULTATION NATIONALE..... | 4 |
| 2.2.1 | <i>Base légale.....</i> | <i>4</i> |
| 2.2.2 | <i>Synthèse des réactions</i> | <i>5</i> |
| 2.3 | LA CONSULTATION DES RÉGULATEURS DES MÉDIAS | 5 |
| 2.3.1 | <i>Base légale.....</i> | <i>5</i> |
| 2.3.2 | <i>Résultats de la consultation des régulateurs des médias.....</i> | <i>5</i> |
| 2.4 | LA CONSULTATION EUROPÉENNE..... | 6 |
| 2.4.1 | <i>Base légale.....</i> | <i>6</i> |
| 2.4.2 | <i>Mode et résultats de la consultation européenne</i> | <i>7</i> |
| 3 | CADRE RÉGLEMENTAIRE..... | 8 |
| 3.1 | LÉGISLATION | 8 |
| 3.2 | DÉCISION ANALYSE DE MARCHÉ DU 1 ^{ER} JUILLET 2011..... | 9 |
| 4 | ANALYSE DE L'OFFRE DE RÉFÉRENCE | 13 |
| 4.1 | ÉLÉMENTS MANQUANTS | 13 |
| 4.1.1 | <i>Fast channel zapping et retransmission</i> | <i>13</i> |
| 4.1.2 | <i>Réutilisation des images TV pour les services, comme catch-up, enregistrement à distance & multi-screen.....</i> | <i>15</i> |
| 4.1.3 | <i>Couverture et disponibilité du nombre de streams SD/HD.....</i> | <i>18</i> |
| 4.2 | TRANSPARENCE QUANT À L'ÉVOLUTION DE L'OFFRE..... | 19 |
| 4.2.1 | <i>Ajout d'une chaîne à l'offre d'émission commune</i> | <i>19</i> |
| 4.2.2 | <i>Suppression d'une chaîne dans l'offre d'émission commune.....</i> | <i>20</i> |
| 4.2.3 | <i>Capacité disponible des chaînes dédiées.....</i> | <i>22</i> |
| 4.2.4 | <i>Adaptations ayant un impact sur le micrologiciel des décodeurs</i> | <i>23</i> |
| 4.2.5 | <i>Fermeture des centraux</i> | <i>25</i> |
| 4.3 | IMPLÉMENTATION DE L'OFFRE..... | 25 |
| 4.3.1 | <i>Timing</i> | <i>25</i> |
| 4.3.2 | <i>Activation de l'offre multicast et de XML Description</i> | <i>26</i> |
| 4.3.3 | <i>Documents sur le site internet sécurisé.....</i> | <i>27</i> |
| 4.4 | AUTRES REMARQUES SPÉCIFIQUES SUR L'OFFRE DE RÉFÉRENCE..... | 28 |
| 4.4.1 | <i>Annexe 1 – Clauses et conditions générales.....</i> | <i>28</i> |
| 4.4.2 | <i>Annexe 2 – Caractéristiques techniques</i> | <i>29</i> |
| 4.4.3 | <i>Annexe 3 – P&O.....</i> | <i>30</i> |
| 4.4.4 | <i>Annexe 4 – Service Level Agreements</i> | <i>30</i> |
| 5 | DÉCISION | 31 |
| 6 | VOIES DE RECOURS..... | 32 |
| | ANNEXE: OFFRE DE REFERENCE | 33 |

1. INTRODUCTION

1. Le 1er juillet 2011, la Conférence des Régulateurs du secteur des communications électroniques (CRC) a pris une décision concernant l'analyse des marchés large bande¹. Dans cette décision, une série de mesures sont imposées à l'opérateur puissant sur le marché, à savoir Belgacom. L'une de ces mesures est la mise en place d'une nouvelle obligation d'accès concernant la fonctionnalité multicast. Il y est également stipulé que Belgacom a le droit de soumettre une proposition alternative à la fonctionnalité multicast.
2. Dans un courrier du 19 septembre 2011, Belgacom a soumis une proposition à l'IBPT dans laquelle elle a développé un type de service de gros qui constitue une proposition alternative au multicast.
3. Dans la décision du 4 janvier 2012, l'IBPT a approuvé la proposition alternative suivante :

« Vu les possibilités offertes par la proposition alternative et la rapidité avec laquelle cette solution peut être implémentée, l'IBPT est d'avis que cette proposition, à savoir l'accès à une plateforme IPTV comme alternative au multicast, peut être approuvée. Par conséquent, Belgacom doit continuer à développer cette solution en un produit à part entière qui sera inclus dans une adaptation de l'offre de référence dans le délai prévu dans la décision de la CRC du 1^{er} juillet 2011². L'IBPT attend par conséquent une proposition d'adaptation de l'offre de référence de Belgacom dans les deux mois qui suivent la publication de la présente décision. »³

4. Le 6 mars 2012, Belgacom a transmis à l'IBPT une proposition d'offre de référence. Dans l'offre de Belgacom, la plateforme IPTV est partagée pour le broadcast, tout ce qui concerne la VoD, l'interactivité, les set-top boxes avec leur middleware ainsi que la distribution des clés restant à la discrétion des OLO.
5. La présente décision vise à évaluer les aspects qualitatifs de l'offre de référence proposée.

¹ <http://www.bipt.be/ShowDoc.aspx?objectID=3540&lang=fr>

² Décision de la CRC du 1^{er} juillet 2011 concernant l'analyse des marchés large bande, point 1109, 331 et s.

³ Paragraphe 50 de la [Décision du Conseil de l'IBPT du 4 janvier 2012 concernant l'approbation de l'offre proposée par Belgacom comme alternative au remède "multicast"](#), 21.

2 PROCÉDURE

2.1 DÉROULEMENT DE LA PROCÉDURE

6. Le 6 mars 2012, Belgacom a transmis à l'IBPT une proposition d'offre de référence.
7. Le 16 mars 2012, l'IBPT a lancé une préconsultation qui a duré jusqu'au 30 mars 2012. EDPNet et Mobistar ont transmis à l'IBPT leurs réactions à cette proposition.
8. Le 28 mars 2012 et le 12 avril 2012, l'IBPT a convoqué une réunion pour discuter de la proposition de Belgacom et des différentes réactions.
9. À la suite des remarques préliminaires de l'IBPT, Belgacom a apporté, de sa propre initiative, quelques modifications à sa proposition en date du 7 mai 2012 (voir annexe).
10. La présente consultation tient déjà compte de ces modifications.

2.2 CONSULTATION NATIONALE

2.2.1 Base légale

11. La consultation publique est organisée conformément aux articles 139 et 140 de la loi du 13 juin 2005 relative aux communications électroniques :

« Art. 139. L'Institut peut organiser pour l'application de la présente loi une consultation publique conformément à l'article 14 de la loi du 17 janvier 2003 relative au statut du régulateur des secteurs des postes et des télécommunications belges. »

« Art. 140. Pour autant qu'un projet de décision de l'Institut soit susceptible d'avoir des incidences importantes sur un marché pertinent, l'Institut organise une consultation publique préalable d'une durée maximale de deux mois, dans le respect des règles de confidentialité des données d'entreprise. Toutes les informations relatives aux consultations publiques en cours sont centralisées à l'Institut. Les résultats de la consultation publique sont rendus publics, dans le respect des règles de confidentialité des données d'entreprise. Le Roi précise, après avis de l'Institut, les modalités de la consultation publique et de la publicité de ses résultats. »

12. Le paragraphe 1109 de la décision de la CRC du 1^{er} juillet 2011 précise que l'IBPT prendra une décision sur l'offre de référence à présenter par Belgacom si la proposition alternative sur les fonctionnalités multicast est acceptée.

« Belgacom doit communiquer à l'IBPT une proposition d'adaptation de l'offre de référence dans les 2 mois après l'approbation de cette alternative par l'IBPT. L'IBPT adoptera ensuite une ou plusieurs décisions concernant les aspects

qualitatifs et quantitatifs de la proposition de l'offre de référence de Belgacom. L'offre de référence concernant ladite alternative au multicast devra être opérationnelle au plus tard 6 mois à compter de la décision de l'IBPT concernant au moins les aspects qualitatifs de la proposition de l'offre de référence faite par Belgacom. »⁴

2.2.2 Synthèse des réactions

13. [À compléter ultérieurement]

2.3 LA CONSULTATION DES RÉGULATEURS DES MÉDIAS

2.3.1 Base légale

14. Les régulateurs des médias seront consultés après la consultation nationale.

15. L'article 3 de l'accord de coopération du 17 novembre 2006⁵ stipule que dans certains cas, un projet de décision doit être transmis aux autres régulateurs :

« Art. 3. Chaque projet de décision d'une autorité de régulation relatif aux réseaux de communications électroniques est transmis par cette autorité aux autres autorités de régulation énumérées à l'article 2, 2°, du présent accord de coopération.

Les autorités de régulation consultées font part de leurs remarques à l'autorité de régulation qui a transmis le projet de décision dans les 14 jours civils. Dans ce délai, chacune des autorités de régulation consultées peut demander que la Conférence des Régulateurs du secteur des Communications électroniques (ci-après dénommée la CRC) soit saisie du projet de décision. Cette demande d'envoi immédiat à la CRC est motivée.

L'autorité de régulation concernée prend en considération les remarques qui lui sont fournies par les autres autorités de régulation et leur envoie le projet de décision modifié. Ces dernières disposent, après réception du projet de décision modifié, d'un délai de 7 jours civils pour demander que la CRC soit saisie du projet de décision modifié. »

2.3.2 Résultats de la consultation des régulateurs des médias

16. [À compléter ultérieurement]

⁴ Décision de la CRC du 1^{er} juillet 2011 concernant l'analyse des marchés large bande, point 1109, 331 et s.

⁵ Accord de coopération du 17 novembre 2006 entre l'Etat fédéral, la Communauté flamande, la Communauté française et la Communauté germanophone relatif à la consultation mutuelle lors de l'élaboration d'une législation en matière de réseaux de communications électroniques, lors de l'échange d'informations et lors de l'exercice des compétences en matière de réseaux de communications électroniques par les autorités de régulation en charge des télécommunications ou de la radiodiffusion et la télévision, M.B., 28 décembre 2006, 75371.

2.4 LA CONSULTATION EUROPÉENNE

2.4.1 Base légale

17. L'article 7, § 3, de la Directive Cadre⁶, tel que modifié par l'article 1, 6°, de la Directive 2009/140/CE⁷ prévoit la consultation de la Commission européenne, de l'ORECE et des autorités réglementaires nationales dans les termes suivants :

« 3. Sauf disposition contraire dans les recommandations ou les lignes directrices arrêtées conformément à l'article 7 ter au terme de la consultation visée à l'article 6, dans les cas où une autorité réglementaire nationale a l'intention de prendre une mesure qui :

a) relève de l'article 15 ou 16 de la présente directive, ou de l'article 5 ou 8 de la directive 2002/19/CE (directive « accès ») ; et

b) qui aurait des incidences sur les échanges entre les États membres,

elle met à disposition de la Commission, de l'ORECE et des autorités réglementaires nationales des autres États membres, simultanément, le projet de mesure ainsi que les motifs sur lesquels la mesure est fondée, conformément à l'article 5, paragraphe 3, et en informe la Commission, l'ORECE et les autres autorités réglementaires nationales. Les autorités réglementaires nationales, l'ORECE et la Commission ne peuvent adresser des observations à l'autorité réglementaire nationale concernée que dans un délai d'un mois. Le délai d'un mois ne peut pas être prolongé. »

18. L'article 141 de la loi du 13 juin 2005 relative aux communications électroniques stipule que la Commission européenne doit être consultée comme suit :

« Art. 141. Pour autant qu'un projet de décision de l'Institut puisse avoir des incidences sur les échanges entre les États membres et qu'il tende à :

6° imposer la modification de l'offre de référence, en application de l'article 59, § 4,

[...] l'Institut consulte sans délai la Commission européenne et les autorités réglementaires nationales des États membres.

⁶ Directive 2002/21/CE du Parlement européen et du Conseil du 7 mars 2002 relative à un cadre réglementaire commun pour les réseaux et services de communications électroniques (J.O.C.E. 24 avril 2002, L 108, 24 avril 2002, 41.

⁷ Directive 2009/140/CE du Parlement européen et du Conseil du 25 novembre 2009 modifiant les directives 2002/21/CE relative à un cadre réglementaire commun pour les réseaux et services de communications électroniques, 2002/19/CE relative à l'accès aux réseaux de communications électroniques et aux ressources associées, ainsi qu'à leur interconnexion et 2002/20/CE relative à l'autorisation des réseaux et services de communications électroniques, JO L 337, 18 décembre 2009, 48.

L'Institut prend en considération les observations qui lui sont adressées par la Commission européenne et les autorités réglementaires des États membres dans le délai fixé par le Roi. »

19. Le présent article 141 de la loi relative aux communications électroniques ne fait pas encore référence à la consultation obligatoire de l'ORECE, étant donné que la Belgique n'a pas encore transposé la Directive 2009/140/CE en droit national. Toutefois, étant donné que le délai de transposition de cette directive a expiré⁸ et que l'IBPT estime que le nouvel article 7, 3 °, a un effet immédiat, l'ORECE sera également consulté.

2.4.2 Mode et résultats de la consultation européenne

20. [À compléter ultérieurement]

⁸ L'article 5 de la Directive 2009/140/CE stipule que les États membres doivent avoir transposé les dispositions de ladite directive au plus tard le 25 mai 2011.

3 CADRE RÉGLEMENTAIRE

3.1 LÉGISLATION

21. En vertu de la loi du 13 juin 2005 relative aux communications électroniques⁹, les opérateurs disposant d'une puissance significative sur le marché¹⁰ peuvent, après analyse de ce marché, se voir imposer (notamment) des obligations en matière d'accès, de non-discrimination, de détermination des coûts et de transparence¹¹. L'association des obligations de transparence et de non-discrimination peut amener un régulateur à contraindre un opérateur PSM à proposer une offre de référence¹².
22. Le but de la publication d'une offre de référence est de fournir des précisions sur les conditions à remplir pour pouvoir bénéficier des services de l'opérateur puissant sur le marché et évaluer suffisamment à l'avance si ces conditions sont effectivement raisonnables. Elle doit en outre être suffisamment détaillée pour garantir que les opérateurs ne devront pas payer pour des ressources inutiles pour le service souhaité. L'article 59 § 2 de la loi du 13 juin 2005 relative aux communications électroniques stipule en outre que : « [L'offre de référence] comprend une description des offres pertinentes réparties en divers éléments selon les besoins du marché, accompagnée des modalités et conditions correspondantes, y compris des tarifs ».
23. L'offre de référence doit correspondre à la réalité et doit donc, si nécessaire, pouvoir être actualisée. Conformément à l'article 59, § 4 de la loi du 13 juin 2005 relative aux communications électroniques du 13 juin 2005, l'IBPT doit à tout moment pouvoir modifier l'offre de référence pour s'adapter aux évolutions des offres de Belgacom et aux demandes des opérateurs alternatifs. Belgacom est tenu d'acquiescer aux demandes de l'IBPT de publier des éléments supplémentaires. De plus, l'article 59, § 5 de la loi du 13 juin 2005 précise : « Toute offre de référence est, préalablement à sa publication, approuvée par l'Institut ». Toutes les modifications de l'offre de référence proposées par Belgacom doivent également être approuvées par l'IBPT.
24. En outre, et pour autant que nécessaire, l'IBPT souhaite insister sur ce qui suit. Le fait que certains éléments de l'offre de référence visée par cette décision soient restés inchangés ne signifie en rien que l'IBPT aurait perdu sa faculté de les modifier ultérieurement. ¹³

⁹ Ci-après « LCE ».

¹⁰ Ci-après opérateurs SMP.

¹¹ Art. 58-59 et 62 LCE.

¹² Art. 59 LCE.

¹³ Bruxelles, 27 juin 2008, 2006/AR/468, considérants 12 et 13; Bruxelles, 9 mai 2008, 2005/AR/1028; Bruxelles, 19 mai 2009, 2007/AR/302, considérant 114.

3.2 DÉCISION ANALYSE DE MARCHÉ DU 1^{ER} JUILLET 2011

25. La décision du 1^{er} juillet 2011 relative à l'analyse des marchés large bande est reprise par la Conférence des Régulateur du secteur des communications électroniques (CRC) sur la base de l'article 3 de l'accord de coopération du 17 novembre 2006.¹⁴
26. En vertu de l'article 6 de l'accord de coopération du 17 novembre 2006¹⁵, l'IBPT est responsable de l'exécution de la décision de la CRC du 1^{er} juillet 2011 concernant l'analyse des marchés large bande.
27. Dans sa décision du 1^{er} juillet 2011, la CRC a décidé d'imposer l'accès concernant la fonctionnalité multicast :

« L'IBPT impose à Belgacom de fournir l'accès à un produit bitstream comprenant des fonctionnalités « multicast » (voir description technique à l'annexe 3) équivalentes à celles fournies par Belgacom en interne à ses filiales ou à ses partenaires pour la fourniture de ses services de détail.¹⁶ »

28. La décision de la CRC prévoit toutefois également la possibilité pour Belgacom de proposer une alternative au multicast dans le mois qui suit la publication.

« Dans le mois à dater de la publication de la présente décision, Belgacom peut communiquer à l'IBPT les caractéristiques essentielles d'un autre type de service de gros qui constituerait une proposition alternative au multicast (comme par exemple l'accès à la plateforme IPTV de Belgacom), pour autant que cette alternative permette aux opérateurs xDSL d'offrir un service de détail de diffusion de contenus vidéos en format point à multipoint leur permettant de se différencier en termes de contenus (offrir à leurs clients des chaînes supplémentaires à celles proposées par Belgacom à ses propres clients ainsi que de ne pas reprendre certaines chaînes de l'offre de détail Belgacom). L'IBPT se prononcera sur cette proposition alternative.¹⁷»

¹⁴ Accord de coopération du 17 novembre 2006 entre l'État fédéral, la Communauté flamande, la Communauté française et la Communauté germanophone relatif à la consultation mutuelle lors de l'élaboration d'une législation en matière de réseaux de communications électroniques, lors de l'échange d'informations et lors de l'exercice des compétences en matière de réseaux de communications électroniques par les autorités de régulation en charge des télécommunications ou de la radiodiffusion et la télévision, M.B. 28 décembre 2006, 75371.

¹⁵ « L'autorité de régulation qui avait soumis le projet de décision est responsable de l'exécution de la décision de la CRC. Cette autorité de régulation informe les autres autorités de régulation énumérées à l'article 2, 2^o, du présent accord de coopération des mesures prises en exécution de la décision de la CRC. »

¹⁶ Décision de la CRC du 1^{er} juillet 2011 concernant l'analyse des marchés large bande, point 1105, 330.

¹⁷ Décision de la CRC du 1^{er} juillet 2011 concernant l'analyse des marchés large bande, point 1109, 331 et s.

29. La décision stipule donc que si Belgacom soumet une proposition alternative à l'IBPT, celui-ci devra l'examiner. La solution finalement retenue fera l'objet d'une consultation nationale et fera ensuite l'objet d'une décision de l'IBPT.

« Par ailleurs, l'IBPT a pris un soin particulier à veiller à la proportionnalité du remède dans le chef de l'opérateur PSM et a ainsi veillé à laisser à ce dernier, la possibilité de proposer des alternatives au remède d'accès aux fonctionnalités multicast. La solution finalement retenue sera par ailleurs soumise à une consultation nationale et fera l'objet d'une décision de l'IBPT.¹⁸ »

30. La décision précise encore que si l'IBPT approuve la proposition alternative de Belgacom, cette dernière devra soumettre une modification concrète de l'offre de référence à l'IBPT dans les 2 mois qui suivent l'approbation. L'IBPT vérifiera alors les modifications proposées à l'offre de référence et prendra une ou plusieurs décisions concernant les aspects qualitatifs et quantitatifs de celles-ci. Belgacom dispose d'un délai de six mois à dater de la décision de l'IBPT concernant au moins les aspects qualitatifs de la proposition d'offre de référence pour rendre opérationnelle l'offre de référence.

31. Comme l'IBPT a approuvé la proposition alternative de Belgacom¹⁹, Belgacom a donc dû proposer une offre de référence. Conformément au contenu de la décision de la CRC²⁰ concernant l'analyse des marchés large bande au sujet de l'offre de référence pour l'accès au débit binaire, une offre de référence contient au minimum les éléments suivants²¹ :

Conditions techniques et tarifaires associées à l'accès à un débit binaire

- éléments du réseau auxquels l'accès à un débit binaire est proposé ;
- informations sur l'architecture du réseau, l'emplacement des points d'accès physiques et la disponibilité des services d'accès dans les parties spécifiques du réseau d'accès ;
- conditions techniques concernant les caractéristiques précises des boucles locales et sous-boucles locales, l'accès, ainsi que l'utilisation de celles-ci ;
- procédures de commande et d'approvisionnement, restrictions d'utilisation et, le cas échéant, procédures contradictoires d'analyse et de test de lignes ;
- un SLA avec amendes est prévu en cas de non-respect du SLA. L'offre de référence peut prévoir, au choix libre du bénéficiaire, un système de prévision raisonnable si cela a une valeur ajoutée pour le bénéficiaire. Aucun système de prévision ne peut être imposé au bénéficiaire. Dans ce dernier cas, le prestataire de services exécute les processus sur une base « best effort ».

¹⁸ Décision de la CRC du 1^{er} juillet 2011 concernant l'analyse des marchés large bande, point 1131, 338 et s.

¹⁹ Paragraphe 50 de la [Décision du Conseil de l'IBPT du 4 janvier 2012 concernant l'approbation de l'offre proposée par Belgacom comme alternative au remède "multicast"](#), 21.

²⁰ Décision de la CRC du 1^{er} juillet 2011 concernant l'analyse des marchés large bande, point 1156, 344.

²¹ Décision de la CRC du 1^{er} juillet 2011 concernant l'analyse des marchés large bande, point 1164, 345 et s.

Services de colocalisation

- information sur les sites pertinents de l'opérateur disposant d'une puissance significative sur le marché et sur les possibilités de colocalisation sur ces sites ;
- caractéristiques de l'équipement : éventuelles limitations des équipements pouvant être installés en colocalisation ;
- mesures mises en place pour garantir la sûreté des locaux ;
- conditions d'accès du personnel des opérateurs concurrents ;
- normes de sécurité ;
- règles applicables à l'allocation d'espace lorsque l'espace de colocalisation est limité ;
- conditions pour l'inspection par les bénéficiaires des sites sur lesquels une colocalisation physique est possible, ou pour lesquels la colocalisation a été refusée.

Systèmes informatiques

- conditions d'accès aux systèmes d'assistance opérationnels, systèmes informatiques ou bases de données pour la réservation de commandes, la fourniture, la commande, la facturation ainsi que les procédures de développement de nouvelles fonctions, la maintenance, et les demandes d'intervention en cas de défaut et la facturation de l'opérateur puissant.

Conditions de fourniture

- délai de réponse aux demandes de fourniture de services et d'installations ; conventions contenant le niveau de service, résolution des problèmes, procédures d'escalade et paramètres de qualité du service ;
- conditions contractuelles standardisées, y inclus, s'il y a lieu, des indemnités prévues en cas de non-respect des délais de fourniture ainsi que les compensations pour la mauvaise vérification des conditions d'intervention et de fourniture ;
- prix ou formules de prix de chaque caractéristique, fonction et installation énumérées ci-dessus.

Limitations techniques

- Seules les limitations techniques, à préciser expressément, dues à l'équipement utilisé, ou à sa version, sont à retenir par Belgacom. Ces limitations ne doivent pas contraindre indûment les choix technologiques des opérateurs tiers. Toute autre possibilité de configuration est à laisser au choix du bénéficiaire ;
- Ceci signifie que l'offre doit contenir un volet technique décrivant les équipements utilisés par Belgacom, les règles d'ingénierie, et les moyens pour permettre un pilotage et des diagnostics à distance.

Migration des utilisateurs finals

- migration des utilisateurs finals DSL de Belgacom ou des utilisateurs finals DSL dans le cadre d'offres de revente DSL vers une mise en service proposée dans le cadre d'un accès à un débit binaire ;
- modalités de migration de l'accès à un débit binaire vers le dégroupage ;
- conditions tarifaires et techniques de cette migration.

32. L'IBPT évaluera l'offre de référence proposée par Belgacom sur la base de la présente décision. Cette décision porte sur les aspects qualitatifs de l'offre de référence.

4 ANALYSE DE L'OFFRE DE RÉFÉRENCE

33. L'analyse de l'IBPT telle qu'elle figure ci-dessous est précédée des éventuelles remarques des opérateurs alternatifs et de Belgacom, reçues par l'IBPT dans un premier stade informel. Ces réactions ne remplacent en aucun cas le processus de consultation officiel et ne représentent que le point de vue initial des parties qui ont participé à la pré-consultation.

4.1 ÉLÉMENTS MANQUANTS

4.1.1 Fast channel zapping et retransmission

Problématique

34. Pour les opérateurs alternatifs, l'ajout des fonctions « fast channel zapping »²² et « retransmission »²³ à l'offre de référence est indispensable pour permettre d'offrir une qualité d'image et une expérience client semblable à celle de Belgacom.

35. Selon les opérateurs alternatifs, la réutilisation de ces fonctionnalités-Belgacom est recommandée étant donné que seule Belgacom dispose d'avantages d'échelle pour installer plusieurs serveurs plus profondément dans le réseau.

36. De par leur échelle plus modeste, les OLO ne peuvent installer qu'un seul serveur, ce qui les prive de redondance ; en cas de problème de réseau ou de serveur, la vitesse de zapping est plus lente et les risques d'erreurs d'image augmentent. De plus, un serveur central unique génère davantage de trafic (et de frais associés) dans le réseau de transport étant donné la plus grande distance entre le serveur et l'utilisateur final.

Réaction de Belgacom

37. Dans l'offre, tout est prévu pour que l'opérateur alternatif puisse offrir ces services lui-même :

37.1. Le serveur VQE²⁴ de l'OLO, qui permet la retransmission et le zapping rapide via unicast, peut être installé de manière centrale chez l'OLO ou via la co-localisation dans chacun des points d'interconnexion (PoP²⁵) des 5 zones d'agrégation.

²² Fast channel zapping: fonction qui, lors du zapping, charge sans attendre les images de la chaîne suivante sur le serveur pour accélérer le zapping.

²³ Retransmission: fonction qui renvoie au téléspectateur les données corrompues afin qu'il y ait pas d'impact sur la qualité d'image en cas d'erreurs de transmission.

²⁴ VQE: Video Quality Experience. Ce serveur VQE fournit les fonctions de retransmission et fast channel zapping.

²⁵ PoP: Point of Presence.

- 37.2. Ce serveur VQE peut utiliser les images captées par Belgacom pour les émetteurs compris dans l'offre d'émission commune de Belgacom. Ces images sont émises via la shared stream interface vers la plateforme (voir section 7.2 de l'annexe 2 : technical specifications) utilisée par l'opérateur alternatif pour émettre ses canaux spécifiques vers la plateforme IPTV de Belgacom. L'OLO, à son tour, doit envoyer les images vers son ou ses serveurs VQE afin de pouvoir offrir à ses clients la même expérience télévisuelle que Belgacom.
38. Même s'il existe une différence d'échelle à l'installation d'un serveur dans chaque PoP, comme Belgacom le fait, un OLO peut y remédier en installant le serveur VQE dans un seul point de son « core network » puis en faisant passer la totalité du trafic via l'OLO Access Line (OAL)²⁶ de l'OLO. Les deux solutions doivent en principe offrir la même expérience télévisuelle.
39. Un serveur centralisé génère en effet du trafic supplémentaire, mais par ailleurs, le fast channel zapping n'engendre qu'un trafic réduit. Il appartient à l'OLO de décider quelle est la solution économiquement la plus indiquée : un seul serveur avec des coûts de transport plus élevés ou un serveur unique par zone d'agrégation. L'IBPT ne peut pas effectuer cette analyse économique pour les opérateurs intéressés, mais estime le prix d'un serveur VQE entre 3251€ et 2828€, en se basant sur le prix d'un serveur CDE111-2 dans le tarif Cisco Global Price List.

Analyse de l'IBPT

40. L'IBPT veut tout d'abord souligner le fait que l'objectif de l'obligation imposée en termes de fonctionnalités multicast est de donner accès aux opérateurs alternatifs à un produit bitstream comprenant des fonctionnalités multicast semblables à celles que Belgacom fournit en interne à ses filiales ou partenaires pour ses services retail²⁷.
41. Cela ne signifie toutefois pas que les opérateurs alternatifs aient droit en toute hypothèse, à toutes les fonctionnalités qui y sont liées. Les opérateurs alternatifs ont droit à demander raisonnablement accès à ces éléments complémentaires, dont il faudra vérifier l'importance afin de pouvoir entrer en concurrence avec Belgacom sur une même base. Par ailleurs, il convient également de déterminer la possibilité pour les opérateurs alternatifs de proposer eux-mêmes ces fonctionnalités de manière efficace. Ce type d'évaluation peut contenir des aspects à la fois opérationnels et tarifaires.
42. Comme son nom l'indique, un serveur fast channel zapping permet au client de changer de canal plus rapidement, permettant le temps de changer de canal d'environ 2 secondes en moyenne à moins d'une seconde. Afin d'obtenir un produit compétitif, il est important que l'expérience numérique égale, au niveau de la convivialité, le temps de changer de canal dans une seconde de la télévision analogique.

²⁶ OAL: OLO access line: ligne d'accès entre des points d'interconnexion Belgacom (PoP) et l'équipement de l'opérateur alternatif.

²⁷ Décision de la CRC du 1^{er} juillet 2011 concernant l'analyse des marchés large bande, point 1105, 330.

43. En premier lieu, la retransmission a un effet sur la robustesse du réseau : en effet, elle évite que le client se trouve momentanément face à un écran noir. L'impact positif d'un serveur de retransmission est donc très important sur les réseaux surchargés où de nombreuses erreurs peuvent survenir, et restreint sur les réseaux robustes où suffisamment de capacité est disponible. De ces jours, certains réseaux IPTV n'utilisent toujours pas ce genre de fonctionnalités.
44. En toute hypothèse, il importe également de noter que Belgacom prévoit toutes les possibilités pour que les OLO puissent eux-mêmes mettre en œuvre le fast channel zapping et la retransmission.
45. Dans ce cadre, il ne semble pas indispensable pour l'IBPT d'obliger Belgacom à offrir ces fonctionnalités aux OLO. L'IBPT a toutefois conscience que les coûts d'implémentation de telles fonctionnalités peuvent jouer un rôle important et, dans ce sens, attend les résultats de la consultation nationale pour mieux pouvoir juger de la proportionnalité des coûts liés à une implémentation propre. C'est pourquoi, l'IBPT demande aux opérateurs intéressés de s'exprimer clairement lors de la consultation, s'ils n'étaient pas d'accord avec la conclusion tirée ci-dessus, tant au niveau financier que technique.

4.1.2 Réutilisation des images TV pour les services, comme catch-up, enregistrement à distance & multi-screen

Problématique

46. Belgacom propose les images TV de l'offre d'émission commune pour le fast channel zapping, mais les opérateurs alternatifs se demandent si ces images TV peuvent également être utilisés pour des services tels que catch-up TV²⁸ (comme Net Gemist, RTL à l'infini, ...), enregistrement à distance (dans le réseau) ou les applications multi-screen²⁹ ?

Réaction de Belgacom

47. Belgacom propose les images TV pour les services unicast nécessitant un cryptage, comme le fast channel zapping et la retransmission. Belgacom estime qu'il incombe à l'OLO de régler lui-même chaque service ne prenant pas en charge le cryptage existant sur la base de son propre video head-end³⁰, ou de demander à Belgacom de s'en charger sur une base commerciale, ce qui ne fait pas partie de l'offre régulée.

²⁸ Regarder sur demande des programmes transmis récemment.

²⁹ Regarder des images TV à partir d'écrans divers comme des tablettes, smartphones, TV portables et postes de télévision bien sûr

³⁰ Video head-end : équipement qui capte les images de plusieurs chaînes et les transmet aux téléspectateurs.

48. Au §. 13 du corps principal de l'offre de référence, Belgacom a indiqué qu'il n'appartient pas à l'offre multicast et l'art. 80 des General Terms & Conditions stipule que l'utilisation de l'offre multicast à des fins non conformes aux caractéristiques techniques décrites à l'annexe 2 peut être un motif de suspension/résiliation du contrat.

Analyse de l'IBPT

49. L'IBPT veut par la présente, réitérer sa position concernant l'accès aux serveurs de fast channel zapping et de retransmission, à savoir que l'objectif de l'obligation imposée en termes de fonctionnalités multicast est de donner accès aux opérateurs alternatifs à un produit bitstream comprenant des fonctionnalités multicast semblables à celles que Belgacom fournit en interne à ses filiales ou partenaires pour ses services retail³¹.

50. Cela ne signifie toutefois pas que les opérateurs alternatifs aient droit en toute hypothèse à toutes les fonctionnalités qui y sont liées. Les opérateurs alternatifs ont droit à demander raisonnablement accès à ces éléments complémentaires, dont il faudra vérifier l'importance afin de pouvoir entrer en concurrence avec Belgacom sur une même base. Par ailleurs, il convient également de déterminer la possibilité pour les opérateurs alternatifs de proposer eux-mêmes ces fonctionnalités de manière efficace. Ce type d'évaluation peut contenir des aspects à la fois opérationnels et tarifaires.

51. Ci-dessous, la situation est analysée pour chaque service.

52. En ce qui concerne la réutilisation des images télévisées pour un enregistrement dans le réseau (nPVR³²) Belgacom a reconnu que c'est techniquement possible. Belgacom a installé un certain nombre de serveurs sur lesquels, pour les chaînes le plus regardées, tout le matériel visuel est stocké 24H/24 durant un mois. Si le spectateur a indiqué à domicile qu'il veut stocker un programme spécifique dans le réseau, il peut le revoir jusqu'à 30 jours après l'émission en contactant ces serveurs et à ce moment-là, le matériel visuel est transmis vers son décodeur à partir d'une heure de début spécifique.

³¹ Décision de la CRC du 1^{er} juillet 2011 concernant l'analyse des marchés large bande, point 1105, 330.

³² nPVR: network Personal Video Recorder.

53. Les opérateurs alternatifs peuvent développer eux-mêmes cette fonctionnalité et demandent de ne réutiliser que les images fournies par Belgacom. Ce n'est pas un problème pour les opérateurs alternatifs parce qu'ils disposent déjà des clés permettant de réutiliser ces images à de telles fins. En plus, ceci n'occasionne pas de frais supplémentaires pour Belgacom. Si les OLO ne peuvent pas réutiliser ces images, ils doivent finir par capter ces chaînes communes eux-mêmes, générant ainsi des coûts supplémentaires. Pour capter, il y a deux possibilités : soit (1) l'OLO peut établir une connexion de données vers le serveur de la chaîne de sorte que celle-ci peut transmettre ses images (si la chaîne est disposée à le faire) soit (2) l'OLO doit lui-même installer un serveur auprès de chaque chaîne pour enregistrer continuellement les images, de sorte qu'il puisse lui-même transmettre les images vers son réseau, si l'utilisateur final demande un enregistrement dans le réseau. Les coûts d'une telle installation ne sont pas à sous-estimer, et il semble donc plus efficace d'utiliser les mêmes images et de profiter ainsi des économies d'échelles de Belgacom (dont les OLO ne disposent pas).
54. La fonctionnalité « enregistrement dans le réseau » est de plus importante pour l'expérience utilisateur étant donné que le nombre d'émissions pouvant être simultanément regardées ou enregistrées est limité par la capacité de la bande passante. L'utilisateur final s'attend à pouvoir regarder la TV et enregistrer des émissions sur différents écrans de télévision à domicile, et revoir par ailleurs des émissions récemment diffusées. L'"enregistrement dans le réseau" permet d'utiliser la capacité disponible de la boucle locale de manière optimale pour la consommation d'images télévisées et permet donc d'éviter qu'une grande partie de la capacité disponible soit occupée par la demande d'enregistrements. C'est pourquoi, l'IBPT demande à cet égard, que tous les opérateurs intéressés s'expriment clairement lors de la consultation, tant au niveau financier que technique.
55. En ce qui concerne la réutilisation des images télévisées pour revoir les émissions récentes, il faut remarquer tout d'abord, que ce contenu peut être offert de deux manières :
- 55.1. soit par la chaîne elle-même en utilisant des fichiers vidéo
 - 55.2. soit par l'opérateur qui a dû créer ces fichiers vidéo lui-même en coupant les images télévisées linéaires et en emballant celles-ci dans des fichiers vidéo, qui pourront être demandés.
56. Belgacom est d'avis qu'un OLO est capable de faire cela lui-même. L'IBPT se demande néanmoins quels sont les frais à supporter par un opérateur alternatif pour offrir une telle fonctionnalité et si un opérateur efficace ne pourrait pas offrir ce service au moyen de l'offre de référence, afin de réaliser ainsi de plus grandes économies d'échelle et de diminuer les coûts pour sa propre plateforme. C'est pourquoi, l'IBPT demande à cet égard, que tous les opérateurs intéressés s'expriment clairement lors de la consultation, tant au niveau financier que technique.

57. La réutilisation d'images TV sur différents écrans tels que les tablettes, smartphones et écrans d'ordinateur (par exemple TV Overal/TV Partout de Belgacom), n'est pas admise par Belgacom parce qu'elle nécessite un recodage³³. Les OLO disposent en plus de toutes les possibilités d'implémenter eux-mêmes ces fonctionnalités. L'exemple d'Alpha Networks, qui propose également de tels services TV par internet dans sa formule Billi, prouve qu'un opérateur alternatif peut développer lui-même de tels services.

4.1.3 Couverture et disponibilité du nombre de streams SD/HD

Problématique

58. Il manque l'information relative à la couverture et la disponibilité du nombre de streams SD & HD pour les différentes zones d'accès. Les OLO veulent :

58.1. avoir confirmation que l'offre est valable pour l'ensemble du réseau VDSL2 ;

58.2. des informations sur le potentiel SD/HD et le nombre de streams pouvant être proposés à un client. Cette information pour le réseau complet est requise pour pouvoir établir un plan d'entreprise (par exemple dans la base de données des rues NSD³⁴) ;

58.3. que l'outil de requêtes (inquiry tool) indique si la HD est possible pour le raccordement concerné.

Réaction de Belgacom

59. Cette offre de référence multicast est disponible pour toutes les lignes d'accès WBA VDSL2.

60. L'opérateur alternatif peut, d'ores et déjà, consulter par ligne d'accès le profil de ligne possible sur la base du LLU Inquiry tool. De plus, le site sécurisé affiche une liste de la bande passante requise pour chaque canal. Sur la base de ces deux documents, l'opérateur alternatif peut déterminer si des chaînes HD peuvent être proposées à l'utilisateur final et combien de chaînes différentes peuvent lui être envoyées simultanément.

³³ Ce service ne peut être offert que si le prestataire de service dispose du « stream » d'images pur des différentes chaînes, après quoi ces images sont encodées et encryptées par écran.

³⁴ NSD: National Street Database

Analyse de l'IBPT

61. L'information relative à la couverture et la disponibilité du nombre de streams SD/HD est importante pour les opérateurs alternatifs afin de pouvoir établir un business plan précis en connaissance de cause. Sans cette information, les opérateurs alternatifs ne peuvent pas évaluer les différents choix stratégiques possibles en les comparant. En groupant ces différentes informations à un seul endroit central, il devient aussi plus facile d'informer suffisamment le consommateur lors de sa commande et le risque d'erreurs humaines lors de l'introduction de la commande diminue.
62. L'IBPT demande que Belgacom fournisse aux OLO l'information demandée pour créer une transparence maximale quant à la portée concrète de l'offre de référence et de ses divers éléments. L'Offre de Référence doit en fait permettre aux opérateurs alternatifs d'acheter seulement les prestations dont ils ont besoin. L'offre de référence doit être suffisamment détaillée de sorte que celui qui souhaite l'accès au débit binaire ne doive pas payer pour des éléments de réseau ou des facilités qu'il n'estime pas nécessaires à la fourniture de ses services³⁵. Dans ce sens, celle-ci doit être claire et transparente. Le but ne peut pas être que l'OLO doive d'abord commencer un puzzle pour rassembler les informations, avant qu'il ne devienne clair pour lui, de savoir quels services sont offerts dans l'offre de référence.

4.2 TRANSPARENCE QUANT À L'ÉVOLUTION DE L'OFFRE

4.2.1 Ajout d'une chaîne à l'offre d'émission commune

Problématique

63. On ne sait pas si Belgacom ajoutera à l'avenir des émissions communes à l'offre existante. Par ailleurs, il n'existe aucune certitude sur le processus qui sera suivi ou sur l'application d'une période de notification pour les opérateurs alternatifs.

Réaction de Belgacom

64. Pour ajouter une nouvelle chaîne à l'offre commune, Belgacom doit obligatoirement supprimer une chaîne commune pour la remplacer par une autre. Si la capacité du réseau est étendue à l'avenir et que la capacité disponible augmente, il sera possible d'ajouter une chaîne sans en supprimer une autre.
65. De plus, l'offre de référence stipule que Belgacom est responsable de la suppression ou de l'ajout de chaînes dans le pool commun, sans que l'offre de chaînes disponibles ne soit détaillée.

³⁵ Décision de la CRC du 1^{er} juillet 2011 concernant l'analyse des marchés large bande, point 1158, 344.

Analyse de l'IBPT

66. L'IBPT souligne dans un premier temps qu'en vertu de l'obligation de non-discrimination, Belgacom ne pourra utiliser pour elle-même une nouvelle configuration des offres large bande (nouveaux paramètres, nouvelles fonctions, nouveaux éléments de réseau, nouvelle technologie, etc.) qu'une fois que cette configuration sera opérationnelle au niveau wholesale³⁶. Cette obligation s'applique également à l'alternative proposée par Belgacom pour la fonctionnalité multicast³⁷.
67. Une période de notification raisonnable pour l'ajout d'une chaîne à l'offre commune est indispensable pour donner le temps aux opérateurs alternatifs de modifier leurs systèmes de soutien opérationnel et informatiques, pour pouvoir acquérir les droits requis en termes de contenu et en informer à temps leur clientèle – et en tous cas au même moment que Belgacom. L'IBPT estime qu'une période de deux mois suffit.
68. Belgacom doit préciser dans l'offre qu'il existe une période de notification de deux mois pour ce qui concerne l'ajout de chaînes à son offre d'émission commune. Ce délai est nécessaire pour que les OLO disposent de suffisamment de temps pour pouvoir lancer le service au même moment que Belgacom.

4.2.2 Suppression d'une chaîne dans l'offre d'émission commune

Problématique

69. Belgacom prévoit que les opérateurs alternatifs disposent d'une période de notification de 2 mois pour prévenir l'utilisateur final de la suppression d'une chaîne de l'offre d'émission commune.
70. Les opérateurs alternatifs se demandent en outre si, en l'espace de deux mois, il est possible de migrer une chaîne de l'offre d'émission commune vers leur capacité de réserve disponible étant donné que celle-ci ne peut faire l'objet d'une adaptation que deux fois par an.

Réaction de Belgacom

71. Les contrats retail de Belgacom ne contiennent aucune obligation concernant les chaînes proposées. Belgacom peut donc en ajouter et en supprimer sans obligation de notification du client final. Belgacom ne considère donc pas l'ajout et/ou la suppression de chaînes comme un changement du contrat, de sorte que, selon Belgacom, il n'y a pas d'infraction à la loi sur les pratiques du marché.

³⁶ Décision de la CRC du 1^{er} juillet 2011 concernant l'analyse des marchés large bande, point 1253, 367 et s.

³⁷ Décision de la CRC du 1^{er} juillet 2011 concernant l'analyse des marchés large bande, point 1156, 344.

72. S'agissant de la gestion de la capacité de réserve disponible, l'opérateur alternatif peut adapter ses paramètres deux fois par an. Dans la gestion de sa capacité de réserve disponible, un opérateur prévoyant pourra prévoir d'emblée de la place pour de futures chaînes pouvant s'ajouter dans les 6 mois à venir à la suite de ses propres négociations de contenu ou par la suppression d'une chaîne du pool commun. Belgacom fait également remarquer qu'elle supprime à peine deux chaînes par an.
73. L'implémentation de la migration d'une chaîne de l'offre d'émission commune vers la capacité de réserve disponible prend 5 semaines à Belgacom ; après la notification, les OLO ont donc encore 3 semaines pour décider s'ils arrêtent également la chaîne concernée ou s'ils la déplacent vers leur capacité de réserve disponible avec captation propre des images.

Analyse de l'IBPT

74. L'IBPT souligne dans un premier temps qu'en vertu de l'obligation de non-discrimination, Belgacom ne peut utiliser pour elle-même une nouvelle configuration des offres large bande (nouveaux paramètres, nouvelles fonctions, nouveaux éléments de réseau, nouvelle technologie, etc.) qu'une fois que cette configuration sera opérationnelle au niveau wholesale³⁸. Cette obligation s'applique également à l'alternative proposée par Belgacom pour la fonctionnalité multicast³⁹.
75. Lorsqu'une chaîne est supprimée de l'offre commune d'émission, elle disparaît en principe également pour l'opérateur alternatif. Cela peut avoir un impact important sur l'expérience de l'utilisateur final, et perturber considérablement le business plan d'un opérateur alternatif. Il est donc logique que les opérateurs alternatifs puissent être informés à temps de telles modifications afin de pouvoir s'y préparer de manière adéquate. Pour pouvoir maintenir une bonne relation avec le client, il faut en outre pouvoir le prévenir à temps de la suppression d'une chaîne. Dans un premier temps, l'IBPT vérifie s'il n'y a pas de discrimination dans le traitement des OLO et de Belgacom retail, et dans un second temps, il vérifie également si les obligations envers l'utilisateur final sont respectées.
76. La suppression de la liste de chaînes commune ne signifie pas obligatoirement que l'opérateur alternatif ne puisse plus l'émettre. L'offre de cette chaîne devra cependant s'effectuer à partir de ce moment-là via un canal dédié. Pour que l'opération se déroule de manière souple et efficace, il est également nécessaire que l'OLO dispose de suffisamment de temps.

³⁸ Décision de la CRC du 1^{er} juillet 2011 concernant l'analyse des marchés large bande, point 1205, 357 e s.

³⁹ Décision de la CRC du 1^{er} juillet 2011 concernant l'analyse des marchés large bande, point 1156, 344.

77. Dans le cadre de la consultation, l'IBPT demande ce que le secteur pense des arguments avancés par Belgacom pour justifier une période de notification de 2 mois. Si les opérateurs alternatifs estiment qu'une période de notification plus longue est nécessaire, l'IBPT leur demande de communiquer les éléments qui justifient cette demande.
78. Dans le cadre de la présente décision, l'IBPT ne se prononce pas sur l'application de la loi du 6 avril 2010 relative aux pratiques du marché, étant donné qu'il n'est pas compétent pour contrôler le respect de cette loi.

4.2.3 Capacité disponible des chaînes dédiées

Problématique

79. Les opérateurs alternatifs demandent de la transparence sur la manière dont la capacité disponible évoluera pour les chaînes dédiées au cours des prochaines années. Il doit rester suffisamment de capacité disponible pour les chaînes supplémentaires permettant aux opérateurs alternatifs de différencier leur offre de chaînes.
80. En effet, la Décision de la CRC du 1^{er} juillet 2011 concernant l'analyse des marchés large bande prévoit que Belgacom peut proposer une solution alternative pour la fonction multicast, et prévoit explicitement : « [...] pour autant que cette alternative permette aux opérateurs xDSL d'offrir un service de détail de diffusion de contenus vidéos en format point à multipoint leur permettant de se différencier en termes de contenus (offrir à leurs clients des chaînes supplémentaires à celles proposées par Belgacom à ses propres clients ainsi que de ne pas reprendre certaines chaînes de l'offre de détail Belgacom). »⁴⁰

Réaction de Belgacom

81. La capacité de transport restante est actuellement répartie entre 4 parties (Belgacom + 3 OLO). Chaque partie reçoit 25 Mbps de capacité pour les chaînes dédiées.
82. Au bout d'un an, une évaluation de la capacité est prévue⁴¹ sur la base de l'évolution du réseau et du nombre d'acheteurs de cette capacité de réserve disponible. Éventuellement, au terme de cette évaluation, les clients existants pourront demander de la capacité supplémentaire s'il reste de la capacité disponible.
83. Une révision de la capacité disponible à plus long terme est possible pour autant qu'on investisse pour augmenter la capacité de transport.

⁴⁰ Décision de la CRC du 1^{er} juillet 2011 concernant l'analyse des marchés large bande, point 1109, 331 et s.

⁴¹ Décision du Conseil de l'IBPT du 4 janvier 2012 concernant l'approbation de l'offre proposée par Belgacom comme alternative au remède « multicast » imposé par la décision de la CRC du 1^{er} juillet 2011 concernant l'analyse des marchés large bande, point 39, 18.

Analyse de l'IBPT

84. En vertu du principe de transparence, l'IBPT demande à Belgacom de mentionner clairement dans l'offre de référence (chapitre 4.5 du Main Body) que la capacité disponible sera évaluée au bout d'un an. Pour garantir une concurrence loyale et stimuler les investissements, il importe que les futures évolutions de réseau fassent l'objet d'une transparence suffisante au préalable. Cette transparence est nécessaire pour l'opérateur alternatif afin qu'il puisse adapter son modèle commercial au futur réseau et aux nouveaux produits⁴².
85. Toute éventuelle adaptation des règles d'attribution de la capacité de réserve disponible doit être soumise à l'approbation de l'IBPT.

4.2.4 Adaptations ayant un impact sur le micrologiciel des décodeurs

Problématique

86. Il faut davantage de visibilité concernant les évolutions technologiques. Les adaptations Codec ont un grand impact sur le logiciel du décodeur, qui doit être adapté et suffisamment testé par l'OLO. C'est pourquoi ces adaptations doivent être communiquées plus longtemps à l'avance que les 3 mois prévus (Annexe 2 : technical specifications, §40).

Réaction de Belgacom

87. Belgacom a ajouté une explication relative aux adaptations des chaînes partagées (chapitre 13 de l'Annexe 3 - P&O). Dans ce contexte, un délai de notification adapté est prévu en fonction de l'ampleur de l'impact des adaptations afin de les mettre sur de bonnes voies. Un gestionnaire du projet sera désigné pour transmettre les rapports de statut aux opérateurs alternatifs.
88. Lors de la réunion du 12 avril 2012, Belgacom a informé l'IBPT que ce nouveau processus fonctionne avec un timing basé sur les projets et différents jalons (milestones) élaborés avec les OLO :
- Milestone t1 : liste des adaptations aux spécifications et au planning high level. Dans cette phase, Belgacom et les OLO contrôlent l'impact sur le logiciel de la plateforme TV et du décodeur.
 - Milestone t2 : accord entre Belgacom et les OLO quant au planning final, suivi d'une série de tests dans les laboratoires des OLO. Belgacom fournit un ou plusieurs échantillons du stream adapté pour permettre aux OLO d'effectuer leurs propres essais en laboratoire.
 - Milestone t3 Live Testing : Belgacom fournit un stream adapté sur la plateforme Belgacom TV (avec adresse multicast) pour pouvoir effectuer des tests chez l'utilisateur final.

⁴² Décision de la CRC du 1^{er} juillet 2011 concernant l'analyse des marchés large bande, point 1197, 355.

- Milestone t4 : Le feu vert définitif est donné pour procéder à l'adaptation (via une modification de l'offre de référence) une fois que tous les opérateurs ont donné leur accord.
- Milestone t5 Live Release : l'adaptation est effectuée par tous les opérateurs, y compris Belgacom.

89. Ce processus se déroule en parallèle du processus de tests internes chez Belgacom, de sorte qu'il ne peut être question de discrimination entre Belgacom et les OLO.

90. Belgacom a accepté de transmettre une roadmap des évolutions planifiées. Une mise à jour du logiciel du décodeur est prévue en 2013.

Analyse de l'IBPT

91. L'IBPT souligne dans un premier temps qu'en vertu de l'obligation de non-discrimination, Belgacom ne pourra utiliser pour elle-même une nouvelle configuration des offres large bande (nouveaux paramètres, nouvelles fonctions, nouveaux éléments de réseau, nouvelle technologie, etc.) qu'une fois que cette configuration sera opérationnelle au niveau wholesale⁴³. Cette obligation s'applique également à l'alternative proposée par Belgacom pour la fonctionnalité multicast⁴⁴.

92. Dans le cadre de cette consultation nationale, l'IBPT demande quel est l'avis des opérateurs alternatifs sur cette procédure proposée par Belgacom. La méthode proposée permet-elle à l'opérateur alternatif de faire à temps les adaptations nécessaires pour ne pas compromettre sa propre prestation de service ?

93. L'IBPT demande à Belgacom de lui soumettre pour approbation le milestone 4, qui concernerait une modification de l'offre de référence, afin que l'IBPT puisse vérifier si tous les opérateurs ont le temps de se préparer à mettre en œuvre ces adaptations.

94. Un contrôle de l'IBPT est nécessaire étant donné que le service fourni par un opérateur alternatif à sa clientèle peut être mis en péril lorsque celui-ci n'a pas suffisamment de temps pour adapter ses équipements. Cela nuirait considérablement à la concurrence et pourrait occasionner des problèmes pour la clientèle.

95. Enfin, l'IBPT demande à Belgacom, pour des raisons de transparence, de transmettre annuellement une roadmap avec les évolutions prévues du logiciel du décodeur, afin que les opérateurs alternatifs puissent intégrer cet impact dans leur propre roadmap IT et prévoir suffisamment de ressources pour pouvoir implémenter rapidement ces adaptations. L'IBPT propose que ceci soit repris dans la communication annuelle existante relative à l'évolution du réseau Belgacom.

⁴³ Décision de la CRC du 1^{er} juillet 2011 concernant l'analyse des marchés large bande, point 1205, 357 et s.

⁴⁴ Décision de la CRC du 1^{er} juillet 2011 concernant l'analyse des marchés large bande, point 1156, 344.

4.2.5 Fermeture des centraux

Problématique

96. La situation n'est pas claire quant aux conséquences de la fermeture d'une série de centraux dans le cadre des développements du réseau Belgacom, et de l'impact sur l'offre de Belgacom. Dans ce contexte, les OLO demandent quel est l'impact opérationnel de la fermeture des centraux sur l'offre de référence multicast.

Réaction de Belgacom

97. La fermeture des centraux n'a aucun impact sur la partie multicast tant que l'accès WBA reste accessible pour le client, étant donné que le fonction multicast s'ajoute automatiquement à l'accès WBA. Au niveau du central lui-même, aucun élément relatif à la plateforme TV n'est installé.
98. Si l'accès WBA doit subir une migration, cela s'effectue via l'offre de référence WBA VDSL2, mais il n'y a pas d'impact spécifique sur la partie multicast.

Analyse de l'IBPT

99. L'IBPT reconnaît qu'une bonne dose de transparence est essentielle au bon déroulement de ce projet, dont les impacts sont multiples. Dans ce sens, l'IBPT demande à Belgacom de communiquer avec un maximum de transparence envers les parties concernées, conformément au §1192 et suivants de la Décision de la CRC du 1^{er} juillet 2011 concernant l'analyse des marchés large bande.

« Dans le cadre de la transition vers les NGA/NGN comme expliqué en section 6.2.2., Belgacom communiquera à l'IBPT et aux opérateurs alternatifs ses projets en matière de développement des réseaux par région sur une période de cinq ans. Les informations communiquées englobent entre autres :

- *toutes les adaptations prévues aux points d'accès de gros existants ;*
- *toutes les fermetures prévues de points où l'accès de gros est fourni ;*
- *le calendrier des transformations de réseau attendues/prévues. »*

4.3 IMPLÉMENTATION DE L'OFFRE

4.3.1 Timing

Problématique

100. Les opérateurs alternatifs demandent de clarifier le planning d'implémentation de l'offre de référence multicast.

Réaction de Belgacom

101. Le release du 13 mars 2013 contiendra les éléments essentiels de provisioning, repair & monitoring. Belgacom s'attend à ce qu'après ce release, 3 semaines supplémentaires soient nécessaires pour éliminer tous les bugs du logiciel.

102. Un « friendly user test » d'un mois pourra ensuite démarrer. Il est ici essentiel que l'interface pour les commandes et l'échange de clés CAS soit suffisamment testé.
103. Belgacom fournira également un document « Roles & Responsibilities » pour les décodeurs de la plateforme.

Analyse de l'IBPT

104. L'IBPT répète ici, pour être tout à fait clair, que Belgacom doit respecter le timing d'implémentation tel qu'il est prévu dans la décision d'analyse de marché :

« L'offre de référence concernant ladite alternative au multicast devra être opérationnelle au plus tard 6 mois à compter de la décision de l'IBPT concernant au moins les aspects qualitatifs de la proposition de l'offre de référence faite par Belgacom. »⁴⁵

105. L'implémentation des fonctions multicast doit être efficace et ciblée afin de pouvoir servir au développement d'une concurrence saine sur le marché de la large bande.
106. Par ailleurs, il importe également qu'il existe une transparence suffisante entre Belgacom et les opérateurs alternatifs pendant la période d'implémentation-même. Pour les services de support des opérateurs alternatifs, il est essentiel d'être informé à temps des étapes suivantes afin qu'ils puissent se préparer à temps et de manière adéquate à chaque nouvelle étape.
107. Dans le cadre de la consultation nationale, l'IBPT demande une réaction des opérateurs alternatifs quant à la faisabilité du timing proposé par Belgacom.
108. Par ailleurs, dans le cadre de cette consultation, l'IBPT demande également quel est le timing des opérateurs alternatifs pour l'implémentation de leurs propres systèmes IT.

4.3.2 Activation de l'offre multicast et de XML Description

Problématique

109. La confusion règne quant à la procédure de commande parmi les OLO, qui ignorent s'il est possible de commander ensemble l'internet et la TV pour un nouveau client au moyen d'un seul XML. On ne sait pas clairement comment un client WBA VDSL2 sans TV peut changer de situation pour un produit WBA avec TV. Il faut davantage de transparence au sujet des procédures et processus que Belgacom mettra à disposition dans ce contexte.
110. En cas d'adaptation à la description XML pour la TV (ce qui a également un impact sur WBA), celle-ci doit être disponible au moins 6 mois avant le lancement.

⁴⁵ Décision de la CRC du 1^{er} juillet 2011 concernant l'analyse des marchés large bande, point 1109, 331 et s.

Réaction de Belgacom

111. Pour la TV, il suffit de commander un P3⁴⁶ VLAN supplémentaire. Celui-ci peut être commandé en même temps qu'une ligne WBA ou séparément lorsque la ligne WBA existe déjà. Belgacom a clarifié la procédure d'activation dans une nouvelle version de l'offre de référence (chapitre 9 de l'Annexe 3 - P&O) le 7 mai 2012.

112. Il s'agit d'une adaptation IT minimale étant donné que les structures XML pour la commande d'un VLAN avec priorité P3 sont réutilisées :

112.1. Une petite adaptation via un message « change » dans l'offre WBA VDSL2 si le multicast est ajouté à une ligne WBA existante ;

112.2. ou via « provide new » pour une nouvelle ligne WBA VDSL2, afin de commander en même temps un accès large bande et la fonction multicast.

113. Le timing pour la description XML doit encore être communiqué par Belgacom.

Analyse de l'IBPT

114. L'accès aux fonctions multicast doit être efficace et ciblé afin de pouvoir servir au développement d'une concurrence saine sur le marché de la large bande. La fourniture de ce type de service doit également prendre en considération les principes essentiels de transparence et non-discrimination. A cet égard, l'IBPT considère que l'explication fournie par Belgacom est suffisante, étant donné que le multicast est un service ajouté à l'offre WBA VDSL2 au moyen d'un nouveau VLAN et n'implique donc pas plus que de "cocher une case" lors de la commande d'une ligne WBA VDSL2.

115. Dans le cadre de la consultation, l'IBPT demande si, après les explications fournies par Belgacom, certains aspects de la procédure d'activation manquent encore de clarté pour le secteur.

116. Dans le cadre de la consultation nationale, l'IBPT demande par ailleurs à Belgacom de mettre à disposition la description du contenu XML au moins 6 mois avant le lancement afin que l'OLO puisse développer à temps ses systèmes IT et démarrer le produit dès que Belgacom lance cette offre de référence multicast.

4.3.3 Documents sur le site internet sécurisé

Problématique

117. Les opérateurs alternatifs demandent quand les documents mentionnés dans l'offre de référence seront disponibles sur le site internet sécurisé.

⁴⁶ La priorité P3 est nécessaire pour fournir des images d'une qualité suffisante.

Réaction de Belgacom

118. Belgacom va dresser la liste des documents qui seront disponibles sur le site internet sécurité, et communiquera un timing pour chaque document.

Analyse de l'IBPT

119. L'IBPT demande que Belgacom lui transmette pour le 10 juin 2012 cette liste avec un timing indicatif. L'offre de référence doit permettre aux opérateurs alternatifs d'acheter seulement les prestations dont ils ont besoin. L'offre de référence doit être suffisamment détaillée de sorte que celui qui souhaite l'accès au débit binaire ne doive pas payer pour des éléments de réseau ou des facilités qu'il n'estime pas nécessaires à la fourniture de ses services⁴⁷. L'IBPT examinera ensuite le timing de ces documents avec les opérateurs alternatifs.

4.4 AUTRES REMARQUES SPÉCIFIQUES SUR L'OFFRE DE RÉFÉRENCE

120. Le tableau ci-dessous rassemble et commente les remarques spécifiques des opérateurs alternatifs quant aux différents documents de l'offre de référence.

4.4.1 Annexe 1 – Clauses et conditions générales

| Où ? | Remarque OLO | Réaction de Belgacom | Analyse de l'IBPT |
|----------------|--|---|---|
| Ann1 §26, Ann4 | <p>Les opérateurs alternatifs trouvent que Belgacom doit prendre ses responsabilités en cas de défaillance du système de cryptage (CAS)</p> <p>Cette responsabilité prend la forme d'un SLA et d'un KPI qui garantit que le serveur CAS sera disponible à 99,9%.</p> <p>Comme Belgacom est le gestionnaire du système mis en œuvre par verimatrix, sa responsabilité porte sur le bon fonctionnement du système.</p> | <p>Les clés restent valables un mois. On donne toujours 2 clés, de sorte que l'utilisateur final peut dans tous les cas arriver jusqu'à la fin du mois suivant (au moins 1 mois + 1 jour). En principe, le serveur CAS peut donc être inopérant pendant un mois sans que cela ait un impact sur les utilisateurs finaux des OLO.</p> <p>Belgacom a ajouté une nouvelle section 5.2.4 à l'annexe SLA, pour proposer d'utiliser pour l'interface de cryptage le même timer SLA que celui applicable à OAL dans l'offre WBA VDSL2.</p> | <p>L'OLO doit se procurer les clés chez Belgacom et les stocker chez lui avant de les communiquer aux clients.</p> <p>Étant donné que l'OLO reçoit toujours 2 clés valables jusqu'à la fin du mois suivant, une défaillance du serveur CAS n'aura pas d'effet direct sur l'utilisateur final, qui pourra continuer à zapper.</p> <p>Le problème ne se pose que lorsqu'un serveur CAS reste indisponible plus d'un mois. Il est recommandé que Belgacom donne un SLA et une compensation pour ce cas exceptionnel.</p> <p>Dans le cadre de la consultation, l'IBPT demande si le SLA proposé répond aux besoins des OLO.</p> |
| Ann1 §57 | <p>La qualité des signaux de télévision communs doit être garantie par Belgacom parce que Belgacom est responsable du transport du signal sur le</p> | <p>Belgacom retail ne garantit pas de qualité d'image parce que Belgacom n'est pas responsable de la qualité des images transmises par le</p> | <p>Pour des motifs de transparence, l'IBPT demande à Belgacom de reformuler ce paragraphe pour qu'il soit clair que Belgacom assume la</p> |

⁴⁷ Décision de la CRC du 1^{er} juillet 2011 concernant l'analyse des marchés large bande, point 1158, 344.

| | | | |
|--|------------------|--|---|
| | réseau Belgacom. | fournisseur de contenu. Dans l'offre, Belgacom donne déjà un SLA sur les parties du réseau dont la responsabilité lui incombe : OAL (réseau) et les chaînes de distribution communes (contenu). | responsabilité des OAL (réseau) et de la distribution des chaînes communes (contenu). |
|--|------------------|--|---|

4.4.2 Annexe 2 – Caractéristiques techniques

| Où ? | Remarque OLO | Réaction de Belgacom | Analyse de l'IBPT |
|------------------|---|---|---|
| Ann2 | Belgacom doit confirmer que toutes les chaînes, y compris celles qui sont transmises non cryptées, font partie du paquet de chaînes commun. | Il n'y a pas de chaînes non cryptées. Le paquet de chaînes commun contient toutes les chaînes ; l'OLO peut donc avoir accès à toutes les chaînes dont il acquiert les droits. | Pour des raisons de transparence, Belgacom doit préciser dans l'offre que toutes les chaînes faisant partie du paquet de chaînes commun et dont l'OLO peut acquérir les droits sont intégrées à cette offre. |
| Ann2 §19 | La vitesse DSL disponible doit toujours être assez élevée pour que les signaux des émetteurs n'aient pas d'impact sur les services voix. | VoIP se trouve dans un autre VLAN que la TV multicast. La sortie modem est, elle aussi, différente. Les deux ont la même priorité P3. Pour éviter les paquets exclus, l'OLO peut installer un contrôleur de ressources lié à un décodeur, pour déterminer le nombre de streams reçu par l'utilisateur final, selon la capacité disponible. | La TV comme la voix ont une priorité haute P3. En cas de saturation, les paquets internet, dont la priorité est inférieure, sont exclus. Par sécurité, un OLO peut utiliser un contrôleur de ressources, mais ce n'est pas indispensable. L'IBPT ne voit aucune raison de faire un changement à ce niveau. |
| Ann2 §45 Ann5 | Belgacom ne peut pas adapter unilatéralement la bande passante des canaux étant donné l'impact direct sur les coûts et le business case de l'OLO. Les OLO proposent de ne pas facturer le supplément. | Dans quelques années, le SD évoluera vers le HD pour répondre à la demande du consommateur. Il ne semble pas justifié que cela soit gratuit pour les OLO étant donné que l'offre est orientée sur les coûts. Les tarifs orientés sur les coûts peuvent également baisser si la capacité requise est réduite par un meilleur encodage. | Vu l'impact possible sur le business case des opérateurs alternatifs, il convient que Belgacom soumette à l'approbation de l'IBPT une éventuelle augmentation de capacité des chaînes. Les modèles de coûts seront revus si la capacité d'un grand nombre de chaînes augmente, vu que les avantages d'échelle sont alors plus nombreux. De ce fait, une augmentation de capacité globale n'entraînera pas nécessairement une augmentation de prix de la même ampleur. Belgacom est d'ailleurs obligé de respecter un délai de notification de 2 mois envers |

| | | | |
|--|--|--|--|
| | | | les OLO avant de modifier la capacité. |
|--|--|--|--|

4.4.3 Annexe 3 – P&O

| Où ? | Remarque OLO | Réaction de Belgacom | Analyse de l'IBPT |
|-----------|--|-------------------------------------|---|
| Ann3 §173 | Un Friendly User Test (FUT) suffisamment long, avec suffisamment d'utilisateurs finaux est indispensable pour un lancement fluide. | Le FUT peut durer plus de 10 jours. | Belgacom a adapté l'offre de référence et prévu un FUT de 20 jours. Dans le cadre de la consultation, on attend la réaction du secteur sur ce sujet. |

4.4.4 Annexe 4 – Service Level Agreements

| Où ? | Remarque OLO | Réaction de Belgacom | Analyse de l'IBPT |
|--------------|---|---|--|
| Ann4 5.1.1.2 | Un SLA de 8 jours ouvrables pour l'activation multicast est beaucoup trop long. | 8 jours ouvrables correspondent au SLA de WBA VDSL2 pour la procédure « change VLAN ». Dans la plupart des cas, l'activation sera beaucoup plus rapide. | La procédure d'activation pour le multicast se base sur la procédure d'activation VLAN existante. Elle est en partie manuelle, de sorte que dans le passé, l'Institut a accordé 8 jours ouvrables pour le SLA. |
| Ann4 §53 §81 | Une compensation horaire est indiquée parce que sinon, une fois que le SLA repair timer de la chaîne TV commune de 4h est écoulé, il n'y a plus rien qui incite à résoudre rapidement le problème vu que la compensation calculée par jour ouvrable doit tout de même être payée. | Belgacom a tout intérêt à résoudre le plus rapidement possible ce problème de « shared TV channel », qui touche également ses propres clients retail. | Vu qu'une compensation doit exercer une pression suffisante sur Belgacom pour résoudre le problème, l'IBPT considère qu'une compensation par heure est indiquée : « 1,5€ per working hour delayed » |
| Ann4 9.3.1. | La compensation de 3% du rental fee par jour n'est pas suffisante. Il y a 21 jours ouvrables dans un mois, ce qui donne une compensation de maximum 63% pour une défaillance d'un mois. | En principe, dans la version de 7 mai 2012, Belgacom a adapté la compensation à « 0,5% of monthly recurring fee per working hour ». Mais dans la phrase au-dessus du tableau, les 3% de la proposition initiale sont toutefois toujours avancés à titre de compensation. | D'abord, l'IBPT demande d'apporter des éclaircissements quant à la compensation finale. Il est raisonnable de supposer que la mention des 3% dans cette proposition constitue un oubli et que le rental fee serait totalement remboursé par Belgacom en cas de défaillance d'un mois. |

5 DÉCISION

121.La décision susmentionnée fournit des éléments qui doivent être observés afin d'harmoniser l'offre de référence multicast aux obligations réglementaires à respecter par Belgacom.

122.L'offre de référence, sur base de laquelle la présente décision a été rédigée, doit être adaptée intégralement conformément aux remarques contenues dans la présente décision.

123.Belgacom doit respecter le timing d'implémentation tel qu'il est prévu dans la décision d'analyse de marché :

« L'offre de référence concernant ladite alternative au multicast devra être opérationnelle au plus tard 6 mois à compter de la décision de l'IBPT concernant au moins les aspects qualitatifs de la proposition de l'offre de référence faite par Belgacom. »⁴⁸

124.L'IBPT tient également à souligner que pour la suite du déroulement de la procédure, il attache une grande importance au respect des délais tels qu'ils ont été formulés dans la décision de la CRC du 1er juillet 2011. L'IBPT attend de Belgacom un respect scrupuleux des autres délais d'exécution, puisque c'est de Belgacom qu'émane cette solution alternative. En effet, pour citer Belgacom dans sa lettre du 19 septembre 2011, cette offre alternative constitue une solution partielle pour répondre aux souhaits des OLO de pouvoir proposer le plus rapidement possible une offre TV compétitive.

⁴⁸ Décision de la CRC du 1^{er} juillet 2011 concernant l'analyse des marchés large bande, point 1109, 331 et s.

6 VOIES DE RECOURS

125. Conformément à la loi du 17 janvier 2003 concernant les recours et le traitement des litiges à l'occasion de la loi du 17 janvier 2003 relative au statut du régulateur des secteurs des postes et télécommunications belges, vous avez la possibilité d'introduire un recours contre cette décision devant la Cour d'appel de Bruxelles, Place Poelaert, 1, B-1000 Bruxelles. Les recours sont formés, à peine de nullité prononcée d'office, par requête signée et déposée au greffe de la cour d'appel de Bruxelles dans un délai de soixante jours à partir de la notification de la décision ou à défaut de notification, après la publication de la décision ou à défaut de publication, après la prise de connaissance de la décision.

126. La requête est déposée au greffe de la juridiction d'appel en autant d'exemplaires qu'il y a de parties en cause. La requête contient, à peine de nullité, les indications de l'article 2, §2 de la loi du 17 janvier 2003 concernant les recours et le traitement des litiges à l'occasion de la loi du 17 janvier 2003 relative au statut du régulateur des secteurs des postes et télécommunications belges.

Axel Desmedt
Membre du Conseil

Charles Cuvelliez
Membre du Conseil

Catherine Rutten
Membre du Conseil

Luc Hindryckx
Président du Conseil

ANNEXE: OFFRE DE REFERENCE

Le 7 mai 2012, Belgacom a transmis cette version de l'offre de référence à l'IBPT.

Wholesale Multicast

Main Body

Created on: 06 March 2012

belgacom

together with





together
with



1 Table of contents

| | | |
|----------|--|-----------|
| 1 | Table of contents | 2 |
| 2 | Glossary..... | 3 |
| 3 | Scope of the document | 4 |
| 4 | Description of Wholesale Multicast Services | 5 |
| 4.1 | General | 5 |
| 4.2 | Multicast functionality & Cross-Connect | 7 |
| 4.3 | Shared TV Channels..... | 8 |
| 4.3.1 | Encryption..... | 9 |
| 4.3.2 | Encryption Key Interface..... | 10 |
| 4.3.3 | Shared TV Channel Management..... | 10 |
| 4.4 | Shared TV Channel Interface..... | 10 |
| 4.5 | Dedicated Capacity | 11 |
| 4.5.1 | Dedicated Capacity Injection Interface..... | 11 |
| 4.5.2 | Dedicated Capacity Bandwidth | 12 |
| 4.5.3 | Multicast IP Addresses..... | 12 |
| 4.5.4 | Dedicated Capacity Management..... | 12 |
| 5 | Operational Processes..... | 13 |
| 6 | Pricing and Billing..... | 14 |
| ◆◆◆◆◆ | End of document ◆◆◆◆◆ | 14 |

2 Glossary

- **Available Dedicated Capacity:** network bandwidth reserved for the Customer at initial set-up for the injection of Dedicated Multicast Streams.
- **Broadcaster:** Is the entity emitting the TV signal captured by Belgacom.
- **Customer Equipment:** Any equipment that belongs to the Customer
- **Dedicated Multicast Stream:** Multicast stream of which the signal is under the Customer's responsibility.
- **Encryption Key Interface:** Interface used between Belgacom encryption system and the Customer's encryption system for the exchange of encryption keys.
- **HD Shared Channel:** High Definition Shared TV Channels. The technical features of a High Definition Shared TV Channel are described in Annex 2 – Technical Specifications.
- **IP-DSLAM:** Digital Subscriber Line Access Multiplexer. IP-DSLAMs are located in Belgacom Local Exchanges and they are owned and managed by Belgacom.
- **IPTV Platform:** Technical platform of Belgacom enabling the broadcaster signals capture and formatting before injection into the Belgacom network.
- **IPTV Product:** Any IPTV solution developed by the Customer and relying on the Wholesale Multicast Services provided by Belgacom.
- **LEX:** Belgacom Local Exchange
- **Multicast functionality:** is considered as the functionality to be activated at IP-DSLAM level on a specific User line for enabling the User's decoder to call any Multicast Stream and receive the corresponding TV stream accordingly.
- **Multicast Stream:** is a stream of data injected into the Belgacom network and accessible for Users benefitting from the multicast functionality on its line. A Multicast Stream can be either a Shared TV Channel or a Dedicated Multicast Stream.
- **NNI:** Network Node Interface.
- **nPVR:** Network Personal Recording
- **OAL:** OLO (Ethernet) Access Line. An Access Line is an interface between the Customer Equipment and a Belgacom Service Router located in the Service PoP of the Service Area.
- **OLO:** Other Licensed Operator
- **Ordered Dedicated Capacity:** network bandwidth ordered by the Customer and effectively provisioned by Belgacom for the injection of Dedicated Multicast Streams.
- **P-bit:** priority bit
- **Radio Shared Channel:** The technical features of a Radio Shared TV Channel are described in Annex 2 – Technical Specifications.
- **Right holders:** Content providers and if applicable the competent collecting societies.
- **Service PoP:** a Service PoP provides access to the Belgacom Ethernet network through NNI connection with a Belgacom Service Router.
- **Shared TV Channel:** Multicast TV Stream formatted in the Belgacom IPTV platform and offered to Customers under the Multicast Offer.
- **Shared TV Channel Pool:** Updated List of Shared TV Channels offered by Belgacom under the Multicast Offer.
- **STB:** stands for Set-Top-Box and is the generic terms used for the decoder to be installed between the signal provided by the network and the television set.
- **User:** is the party to which the Customer is delivering IPTV products.
- **UNI:** User to Network Interface.
- **VDSL2:** VDSL2 is an access service based VDSL2 (Very high Speed Digital Subscriber Line 2) technology that allows simultaneous transport of data and voice service, using the same local exchange service loop, to be sent over existing facilities.
- **VLAN:** Virtual Local Area Network. Unless specified otherwise, the word "VLAN" refers specifically to a shared VLAN.
- **VoD:** Video on Demand
- **WBA:** Wholesale Broadband Access.
- **WBA VDSL2:** Wholesale Broadband Access VDSL2, (shared VLAN only).
- **Wholesale Multicast Services:** The services described in the Multicast Offer, also referred to as the Services.

3 Scope of the document

1. This document provides a description of the Wholesale Multicast Services including the method of connection.
2. This document contains the conditions related to the provision by Belgacom to the Customer, of the Wholesale Multicast Services, which will enable the Customer to define its own IPTV Product and to market, distribute and sell under its name and on its behalf its own IPTV products towards Users, using Belgacom's installed and existing network infrastructure and Shared TV Channels, pursuant to the technical limitations of these existing infrastructures for offering the service.
3. This document contains the technical, operational and financial conditions, as well as the applicable terms and conditions related to such a service.
4. The provision of the hereunder-described service supposes the following list of prerequisites that will need to be met at all times and in all circumstances:
 - The Customer has already subscribed to the Belgacom WBA VDSL2 offer.

4 Description of Wholesale Multicast Services

4.1 General

5. The Wholesale Multicast Services are a set of services enabling the Customer to benefit from the Multicast functionality, Shared TV Channels and Dedicated Capacity.
6. The Wholesale Multicast Services are available as an extension of the Belgacom WBA VDSL2 offer which is considered as a prerequisite to the Multicast Offer.
7. The Wholesale Multicast Services covers:
 - The provision by Belgacom on a specific User line of the multicast functionality enabling the Customer's user to call a given Multicast Stream and to receive it accordingly.
 - The provision by Belgacom of an Encryption Key Interface enabling the Customer to fetch encryption keys of Shared TV channels the Customer subscribed to.
 - A pool of Shared TV Channels which are made available to the Customer's Users via the multicast functionality. In respect to the Shared TV Channels provision Belgacom is responsible for the Shared TV Channel signal capture from the broadcaster, the Multicast Stream encoding and encryption according to Belgacom's encryption method.
 - The Shared TV Channel Pool is made up of SD, HD and Radio Shared Channels.
 - The provision of a Dedicated Capacity Injection interface enabling the Customer to inject in the PIM Core Network its own content.
 - The provision of Multicast IP addresses group dedicated to the Customer.
 - The provision of Dedicated Capacity for the transport of the Customer's dedicated content over the Belgacom network and injected through the Dedicated Capacity Injection Interface. The dedicated content so transported is made available at Customer's User through the multicast functionality.
 - The provision of Shared TV Channels Interface enabling the Customer to receive through an OAL up to its infrastructure all encrypted Shared TV channels it subscribed to. The Shared TV Channels transported so are in the same format (encoding and encryption) as the channels available at user end via the multicast functionality.
8. The Prerequisites for benefitting from Multicast functionality on a given WBA VDSL2 User line are:
 - The Customer must, prior to the activation of Multicast functionality on a given User line have a shared VLAN with service quality P3 available in the LEX where the User is connected to.
 - Subsequently the User line must be configured with a service quality VLAN P3.
9. The prerequisites for benefitting from Shared TV Channels are:

- The User to whom the Customer wants to offer a Shared TV channel must have a WBA VDSL2 line fulfilling requirements stated in previous paragraph.
- The Customer must at least have one OAL ending up in one of following Service PoP, for fetching decryption keys:
 - i. o2STR
 - ii. o2MAR
 - iii. o3CEN
 - iv. o3BKC
- The Customer is responsible for dimensioning the OAL bandwidth so that the Encryption Key Interface is properly working.
- The Customer must have brought the proof that it has been granted the content rights corresponding to the Shared TV channel it wants to order.

10. The prerequisites for benefitting from Dedicated Capacity are:

- The User to whom the Customer wants to offer a Multicast dedicated streams out of its Dedicated Capacity must have a WBA VDSL2 line fulfilling requirements stated in previous paragraph.
- The Customer must have one OAL ending up in o2MAR and one OAL ending up in o2STR.
- The Customer is responsible for dimensioning the OAL bandwidth so that the Dedicated Capacity Interface is properly working.

11. The prerequisites for benefitting from the Shared TV Channel Interface are:

- The Customer must have at least one OAL ending up in one of following Service PoP:
 - i. o2STR
 - ii. o2MAR

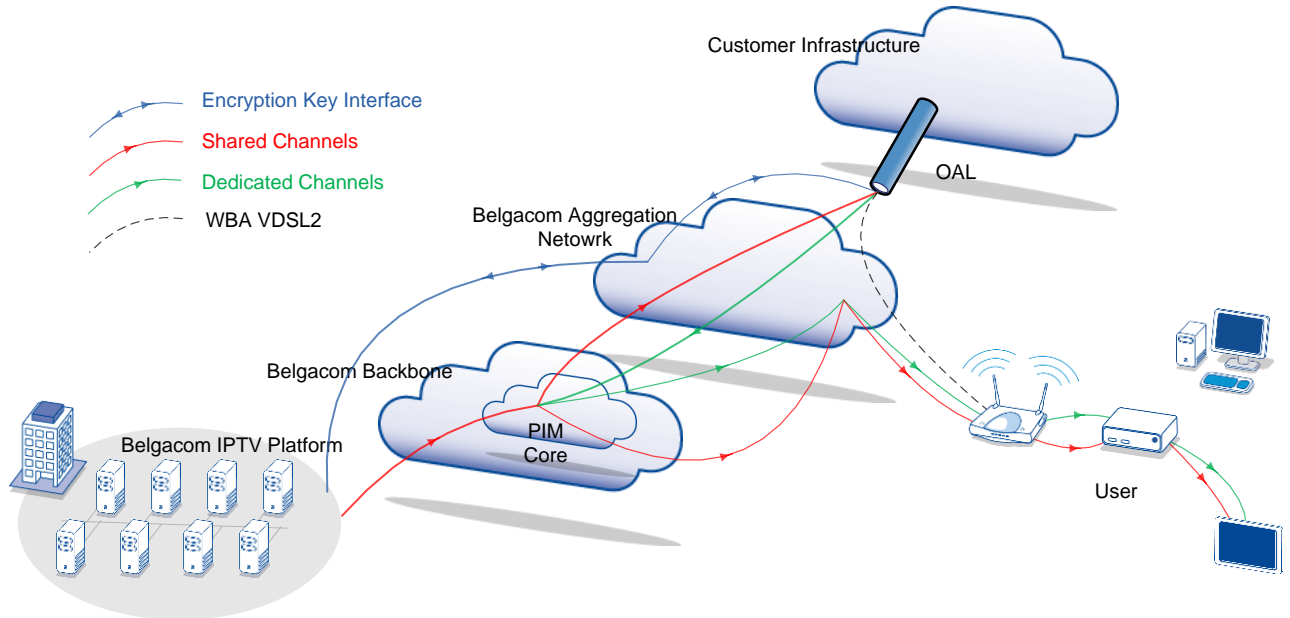

Figure 1: End-to-End Overview

12. The figure 1 gives the end-to-end overview of the Wholesale Multicast Services. The Encryption Key Interface allows the Customer upon request to fetch keys of Shared TV channels it subscribed to. The Shared TV Channels are made available at PIM Core level and merged with Customer Multicast Dedicated streams part of its Dedicated Capacity. The Shared TV Channels and the Multicast dedicated streams can be transported up to the Customer infrastructure over the Shared TV Channel Interface. If the Customer's User line has been previously configured with the multicast functionality the Customer's User could call a given channel and receive it. The Customer is responsible for providing its Customer with Shared TV channel encryption keys (fetched via the Encryption Key Interface) through its WBA VDSL2 access.
13. Any TV service not described in the Multicast Offer is under the Customer responsibility.
14. Specifically following services or products are out of the scope of the present offer:
 - Content Rights of Shared TV Channels
 - Set-Top-Boxes
 - Any unicast TV Services (nPVR, VoD, graphical user interface...)

4.2 Multicast functionality & Cross-Connect

15. The Multicast functionality is an IP-DSLAM feature enabling the User's STB to call a given Multicast Stream and to receive it accordingly in order to display it on the screen.

16. The multicast functionality alone does not enable the User's STB to decrypt the TV signal so received. The Customer is responsible for providing the User's STB with the encryption keys of its Multicast dedicated streams (assuming they are encrypted) and encryption keys of Shared TV Channels it subscribed to.
17. The multicast functionality enables the User's STB to call at any moment another Multicast Stream by leaving the previous one and calling the new one (Multicast Stream zapping).
18. The Customer can activate the multicast functionality on the WBA VDSL2 line of a given User through the Multicast functionality activation on a WBA VDSL2 line ordering process further described in Annex 2.
19. Belgacom will ensure the cross-connection of the Multicast VLAN and a TV unicast VLAN ordered by the Customer as per the WBA VDSL2 offer. The TV unicast VLAN is the WBA VDSL2 shared VLAN of service quality P3 (not P3bis) intended to transport TV unicast services under the Customer responsibility. To have a shared VLAN P3 is a prerequisite before activating the multicast functionality on the WBA VDSL2 line of the Customer's User.
20. The Customer is responsible for dimensioning its WBA VDSL2 shared VLAN in order to take into account new traffic generated by its TV unicast services.
21. The Customer shall at least order and maintain fifteen Shared TV Channels before Belgacom will accept a Multicast functionality activation on WBA VDSL2 User line. This requirement is here after referred as "the Start-up Pack".
22. The Start-up Pack must be made up of SD and HD Shared TV Channels only. Radio Shared Channels are not considered as qualified for being part of the fifteen channels of the Start-up Pack.

4.3 Shared TV Channels

23. Shared TV Channels are Multicast TV Streams offered by Belgacom to the Customers. Belgacom ensures the complete processing chain of Shared TV Channels from the TV signal capture from the Broadcaster up to the injection of the Multicast Stream into the Belgacom Network so that the Multicast Stream is available to Users. This TV processing chain includes the Broadcaster TV signal capture, the TV signal decoding and decryption (decoding and decryption of the signal provided by the broadcaster), the TV Multicast Stream encoding, the TV Multicast Stream encryption with Belgacom encryption key and encryption algorithm deployed at Belgacom and the TV Multicast Stream injection into the Belgacom network.
24. A Shared TV Channel is by definition a channel which is offered by Belgacom to Customers having subscribed to the channel.
25. The pool of Shared TV Channels offered by Belgacom will not include any channel for which Belgacom owns content rights exclusivity.
26. The Shared TV Channel ordering process is further specified in Annex 2.
27. The acquisition of content rights for a given Shared TV Channels is the Customer's responsibility. Belgacom will approve the ordering of a given Shared TV Channel only after a proof has been provided to Belgacom that the Customer has acquired the appropriate content rights.
28. Belgacom offers in its Shared TV Channels pool three types of Shared TV Channels:

- Radio Channels: Audio Content
- SD Channels: Standard Definition Channel
- HD Channels: High Definition Channel

29. The technical features are available in Annex 2 – Technical Specifications.

30. The Customer shall notify Belgacom upfront when a Customer's User intends to resell to or otherwise put the Wholesale Multicast Services at the disposal of a third party.

4.3.1 Encryption

31. A Shared TV Channel is by default available via the multicast functionality to any Customer's User having a Belgacom WBA VDSL2 line and having the multicast functionality activated on it. But the Shared TV Channel is encrypted by Belgacom and can be available in clear only if the User's STB has access to the encryption keys.
32. All Shared Channels provided by Belgacom in the shared channel pool are without exception encrypted.
33. Once the ordering process of a Shared TV Channel is completed Belgacom shall ensure that the encryption key of the Shared TV channel can be fetched by the Customer. The Customer is then responsible for sending the encryption key to the STB of its Users.
34. The Belgacom encryption keys are managed by the Belgacom Content Access Server (CAS). In order to make use of the encryption keys made available by Belgacom the Customer Content Access Server shall be compatible with the Belgacom's CAS.
35. The Customer is responsible for deploying any equipment compatible with the Belgacom Content Access Server and required for making usage of the Encryption Keys provided by Belgacom.
36. A prerequisite for the ordering of Shared TV Channels and the subsequent exchange of encryption keys is the set-up of the Encryption Key Interface. The Customer shall ensure that this prerequisite is fulfilled before any Shared TV Channel ordering.
37. Encryption keys for a given Shared TV Channel are renewed on a regular basis. The Customer shall fetch the encryption keys at a frequency imposed by Belgacom in order to ensure that the Customer has always a valid Encryption Key. Belgacom shall not be hold responsible for any service degradation in case of non-compliance with that requirement.
38. By fetching Encryption Keys the customer fetches all the Encryption Keys it is entitled to and corresponding to Shared TV Channels the Customer subscribed to.
39. The encryption Key renewal date might be different for each Shared TV Channel.
40. Two Encryption Keys are always provided for a given channel while the Customer fetches the Encryption Key for a given Shared TV Channel: the currently valid Encryption Key and the next valid Key.

4.3.2 Encryption Key Interface

41. The Encryption Key Interface is a prerequisite to the provisioning of a Shared TV Channel.
42. The Encryption Key Interface is intended to interconnect the Belgacom's CAS and the Customer's CAS.
43. The Encryption Key Interface is made up of following network pieces:
 - A specific VLAN configured on an OAL. The OAL on which the VLAN is configured is left at Customer discretion but must end up on one of the following Service PoP: o2MAR, o2STR, o2CEN or o3BKC. Further information regarding those Service PoP is available in the WBA VDSL2 offer – Main Body.
 - Network configuration required for connecting the VLAN to the Belgacom CAS.

4.3.3 Shared TV Channel Management

44. Regarding Shared TV Channels the Customer has subscribed to, Belgacom has the right to remove any Shared TV Channel from the Shared TV Channels pool, provided the Customer has been notified two (2) month before its removal. The considered Shared TV Channel stream will accordingly no longer be provided by Belgacom to the Customer.
45. Regarding Shared TV Channels the Customer has not subscribed to, Belgacom has the right in any case to remove the Shared TV Channels from the Shared TV Channel pool without any obligation to notify the Customer. The considered Shared TV Channel stream will accordingly no longer be provided by Belgacom.
46. A Shared TV Channel to be removed from the Shared TV Channels pool will be removed from the list of Shared TV Channels available on the Belgacom secured website two (2) months before its actual stop.
47. Belgacom has the right to reject the ordering of a given Shared TV Channel if it is known that it will be removed within two (2) months following the ordering notification by the Customer.
48. Belgacom has the right to add a Shared TV Channel to the Shared TV Channel pool. This Shared TV Channel will be available for ordering by the Customer.

4.4 Shared TV Channel Interface

49. The Shared TV Channel Interface is aimed at providing the Customer with an interface enabling the transport of all Shared TV Channels the Customer subscribed to through an OAL up to the Customer's infrastructure.
50. The Shared TV Channel interface consists in a specific VLAN configured on the OAL specified by the Customer
51. It is up to the Customer to decide if the Shared TV Channel Interface must be redundant.
52. The Customer is responsible for dimensioning the OAL the Shared TV Channels streams will flow over. Belgacom shall not be hold responsible for any stream quality issue due to a bandwidth shortage on the considered OAL.

53. All Shared TV Channels transported over the Shared TV Channel Interface are encrypted and in the same format as the Shared TV Channels made available to the Customer's Users provided the Customer has subscribed to.

4.5 Dedicated Capacity

54. The Dedicated Capacity is an optional feature aimed at providing the Customer with the capability to inject its own multicast streams into the Belgacom Network.
55. The Dedicated Capacity is made up of:
- Bandwidth in the Belgacom network. The bandwidth ordering can be done either at the initial set-up of multicast or later depending on the Customer's needs and the available bandwidth.
 - i. Initial set-up: The Customer can order up to 25 000 Kbps (Available Dedicated Capacity at initial launch) or less. If the Customer orders less than 25 000 Kbps, Belgacom will make the remaining capacity free so that it could be ordered by anyone else according to a fair split between requestors.
 - ii. Later: There is no guarantee about the feasibility of a dedicated capacity request. Belgacom will assess the request depending on the capacity still available in the network and independently of the Available Dedicated Capacity.
 - A Dedicated Capacity Injection Interface aimed at interfacing the Customer's infrastructure and the Belgacom network.

4.5.1 Dedicated Capacity Injection Interface

56. The Dedicated Capacity Injection Interface must be redundant.
57. Before Belgacom can provision the Dedicated Capacity Injection Interface the Customer must ensure that it has two OAL ending up on Service PoP O2MAR and Service PoP O2STR. This is a prerequisite prior to the setup of the Dedicated Capacity Injection Interface.
58. Belgacom shall configure on both OAL a specific VLAN dedicated to the transport of Customer Multicast streams.
59. The VLAN bandwidth is capped at the Ordered Dedicated Capacity. Through shaping configuration Belgacom reserves the rights to drop any packet making the total bandwidth beyond the Ordered Dedicated Capacity.
60. The Customer is responsible for ensuring the total bandwidth used by the multicast streams flowing over the Dedicated Capacity Injection Interface does not exceed the Ordered Dedicated Capacity
61. Belgacom shall not be held responsible for a multicast stream quality issue if the bandwidth injected by the Customer goes over the Ordered Dedicated Capacity and packets are as a consequence dropped.
62. The Customer is responsible for ensuring the appropriate OAL bandwidth dimensioning so that the Customer's multicast streams can flow over the OAL without any risk of packet drop impacting the multicast stream quality.

63. Belgacom shall not be hold responsible for any multicast stream quality issue due to capacity saturation on the Customer's OAL's.

4.5.2 Dedicated Capacity Bandwidth

64. Included in the Dedicated Capacity is a reserved bandwidth as ordered by the Customer in the Belgacom network from the Belgacom backbone/PIM core, where all multicast streams including the Shared TV channels and the Customer's streams are present, up to the IP-DSLAM.
65. This bandwidth is capped downstream at Dedicated Capacity Injection Interface level as further explained in paragraph above.

4.5.3 Multicast IP Adresses

66. Belgacom will provide the Customer with a set of 32 Multicast IP addresses corresponding to 32 Multicast streams.
67. The Customer shall specify the bandwidth allocated to each of the 32 Multicast streams.
68. The Sum of bandwidths allocated to each multicast IP address can be greater than the Ordered Dedicated Capacity without changing that limitation. The Customer is responsible for injecting streams so that the total bandwidth injected into Belgacom network does not go over the Ordered Dedicated Capacity as specified in paragraph 4.5.1.
69. The Customer's allocated multicast IP addresses and corresponding bandwidth is configured in all Belgacom network IP-DSLAM's.
70. Belgacom offers the Customer the possibility to perform two changes a year at fixed date. Such a change includes a modification of the bandwidth allocated to each multicast IP address.

4.5.4 Dedicated Capacity Management

71. The overall multicast capacity will be reviewed one year after the Customer officially launched its IPTV product based upon the Wholesale Multicast Services.
72. Based upon Belgacom forecasts and the IPTV market status an extension of the Customer's Dedicated Capacity bandwidth will be assessed and capacity reserved but not allocated yet could be redistributed amongst Belgacom and Customers having subscribed to the Wholesale Multicast Offer.

5 Operational Processes

73. The provisioning and repair processes for the Wholesale Multicast Services are detailed in the Annex 3 , Planning and Operations.

6 Pricing and Billing

74. Principle: all Standard Fees as described in Annex 5, Pricing and Billing, will be invoiced to and are to be paid by the Customer whenever relevant.
75. The Customer will receive a monthly invoice containing the fees (recurring and non-recurring) for that period. Invoices related to any relevant fees are to be paid within the foreseen deadlines as set out in the Annex 5, Pricing & Billing document.

◆◆◆◆◆ End of document ◆◆◆◆◆

Wholesale Multicast

Annex 1: General Terms & Conditions

Created on: 06/03/2012

belgacom

together with



General information

This document constitutes an integral part of the Wholesale Multicast Services Offer (hereafter referred to as the “MULTICAST Offer”) communicated to the Belgian Institute for Post and Telecom (here-after the BIPT). It includes the general terms and conditions applicable to the provision of Wholesale Multicast Services offered as an option on Belgacom Wholesale Broadband Access VDSL2. These Wholesale Multicast Services are provided in conformity with the relevant laws and decrees in effect. The present Terms and Conditions shall remain applicable until they are replaced by other terms and conditions.

A distinction should be made between the following:

The Main Body

This document describes in broad terms the conditions of the Wholesale Multicast Services offered by Belgacom as it has been communicated to the BIPT.

The Annex 1, “General Terms and Conditions”

The General Terms and Conditions list the rights and obligations of Belgacom and the Customer with regard to the provision of the Wholesale Multicast Services.

The Annex 2, “Technical Specifications”

The technical conditions define the technical specifications and the quality standards of the Wholesale Multicast Services.

The Annex 3, “Planning & Operations”

The Planning & Operations Manual describes the conditions of delivery of the Wholesale Multicast Services.

The Annex 4, “Multicast Service Level Agreement”

The Multicast Service Level Agreement defines the Terms and Conditions upon which Belgacom will deliver installation and maintenance for the Wholesale Multicast Services.

The Annex 5, “Pricing and Billing”

The Pricing and Billing indicates the rates and the billing and payment conditions for the Wholesale Multicast Services.

The Annex 6, “Prepayment Terms & Conditions”



The General Terms and Conditions, Main Body, Technical Specifications, Planning and Operations, Service Level Agreement, Pricing and Billing, Prepayment Terms and Conditions jointly constitute the Wholesale Multicast Services Offer (hereinafter, the “MULTICAST Offer”).

Anyone may examine the Main Body and Annexes of the MULTICAST Offer, as they are approved by BIPT and applicable at the time of consultation. These are available on Belgacom’s Internet site. Other documents which are referenced in the Main Body or Annexes are available on the Secured website of Belgacom (Personal Page of Belgacom Wholesale) and may be consulted further to the signature of a non-disclosure agreement.



together
with



1 Glossary

The capitalized terms in the present General Terms and Conditions for Wholesale Multicast Services have the meaning as defined below:

| | |
|------------------------------|--|
| Contract | A contract for the provision of a Wholesale Multicast Service according to the terms and conditions of the MULTICAST Offer, and, if any, the specific terms and conditions agreed upon by the Parties. The Contract is concluded as mentioned in article 6 below. Except otherwise agreed by the Parties, the Contract shall be adapted if the MULTICAST Offer is modified. This adaptation shall be in accordance with this MULTICAST Offer's modification. |
| Customer | An operator (as defined by art. 2, 11° Law of 13 June 2005 on electronic communications) who has concluded one or more Contracts with Belgacom. |
| Dedicated Capacity | Network bandwidth reserved for the Customer for the injection of Dedicated Multicast Streams. |
| Dedicated Multicast Stream | Multicast stream of which the signal is under the Customer's responsibility. |
| IPTV Platform | Technical platform of Belgacom enabling the broadcaster signals capture and formatting before injection into the Belgacom network. |
| IPTV Product | Any IPTV solution developed by the Customer and relying on the Wholesale Multicast Services provided by Belgacom. |
| Party | Either Belgacom or Customer. |
| Parties | Collectively, Belgacom and Customer. |
| Request | The Customer's demand concerning the delivery of a Wholesale Multicast Service as described in this Offer. |
| Right holders | Content providers and, if applicable, the competent collecting societies. |
| Shared TV channel | Multicast TV stream formatted in the Belgacom IPTV Platform and offered to Customers under the MULTICAST Offer; an updated list of Shared TV channels ("Shared TV channel Pool") can be found on the Personal Page of the Belgacom Wholesale website |
| User | Any direct customer of the Customer. |
| Wholesale Multicast Services | The services described in the MULTICAST Offer, also referred to as "the Service(s)". |

2 Contract procedure

2.1 Request by the Customer

1. In view of the offering of an IPTV Product to his Users, the Customer must submit his Request for a Service to the Wholesale department of Belgacom by completing and signing the appropriate order form or submitting an order request in electronic format (depending on the type of Service), pursuant to the rules described in the Annex 3 “Planning & Operations”. The terms and conditions for delivering the Services are described here-after.
2. The Customer shall consult the Main Body, the General Terms and Conditions, the list of technical requirements, as well as the other annexes of the MULTICAST Offer.
3. Belgacom may not refuse to execute the Customer's Request conform the MULTICAST Offer, without prejudice to the negotiations between Belgacom and the Customer, except on one of the following grounds:
 - a) the Customer or his authorized agent refuses to provide Belgacom with official documents to identify himself;
 - b) in an emergency situation (i.e. exceptional cases of force majeure as defined hereafter), for the purpose of ensuring the safe operation of the Belgacom network and equipments (including the Belgacom IPTV Platform);
 - c) following the Customer's failure to observe obligations arising from the present General Terms and Conditions for the use of the Service;
 - d) for the purpose of maintaining Belgacom network integrity or the interoperability of the services or for any other technical reasons that make the delivery of the Service impossible;
 - e) the Customer has refused to provide proof of the existence of the unconditional financial guarantee as specified in the provision Financial Guarantees here-under;
 - f) the Customer's Request for access to the Wholesale Multicast Service is unreasonable (in accordance with paragraph 1106 of the CRC decision of July 1st, 2011 regarding the analysis of the broadband markets) on the basis of other grounds than the ones listed hereabove;
 - g) the necessary WBA VDSL2 services as described in Annex 2 “Technical Specifications” are not in place or not installed on behalf of the Customer;
 - h) the Customer has not acquired all appropriate intellectual property rights and authorisations regarding the content/encrypted signal as foreseen in article 18 below.
4. In the event of a refusal on one of the grounds listed in article 3 above, Belgacom shall notify within 3 working days the Customer of its decision and the grounds for the decision by ordinary mail. A copy will be sent to the BIPT in the same delay.
5. The Customer may lodge an appeal against this decision by the procedure provided under the Dispute Resolution Procedure and in accordance with these General Terms and Conditions.

2.2 Conclusion, entry into force and duration of the Contract

6. The provision of the Wholesale Multicast Service is subject to the conclusion of a Contract between Customer and Belgacom. The Contract is concluded when Belgacom has accepted in writing or via electronic way (“Validate” XML), depending on the type of Service (see the rules described in Annex 3 “Planning & Operations”), the Order Form submitted by the Customer.
7. Unless otherwise stipulated, the Contract takes effect on the day after the date on which the Wholesale Multicast Service is made available to the Customer. Belgacom shall confirm this date to the Customer in writing, or via electronic way (“Done” XML).
8. The Service is made available to the Customer for an indefinite term.

3 Services covered by these General Terms and Conditions

9. Belgacom shall provide to Customer and maintain on behalf of Customer Wholesale Multicast Services in accordance with the MULTICAST Offer.
10. Subject to the successful completion of testing as defined in and pursuant to the provisions of the MULTICAST Offer, the Parties will bring the Multicast Services into service on the agreed Bringing into Service Date.
11. The Wholesale Multicast Services shall be implemented in accordance with the technical specifications in Annex 2 “Technical Specifications”.
12. The Wholesale Multicast Services purchased by Customer according to the foregoing will enable Customer to define its own IPTV Products and to market, distribute and sell under its name and on its behalf its own IPTV Products towards his Users. In this respect Belgacom will inform the Customer of any modification of the technical specification, enabling a modification of the services offered, at the latest 3 (three) months before the commercial launch by Belgacom of a commercial service based on these technical specifications.
13. For each User to whom Customer will sell an IPTV Product in accordance with the foregoing, Belgacom will, in accordance with and subject to the limitation set out in the MULTICAST Offer, activate the multicast functionality on the WBA VDSL2 line of the User and offer the possibility to decrypt a specific set of shared TV channels through the provisioning of encryption keys to the Customer. As an option, the Customer can acquire, in accordance with and subject to the limitation set out in the MULTICAST Offer, Dedicated Capacity enabling the Customer to inject his own content in the Belgacom network.
14. Within the limits of what is permitted under the applicable regulatory framework, both Parties shall exchange appropriate operational information as provided in the MULTICAST Offer (including but not limited, in particular, maintenance contact numbers, network information, information required to comply with law enforcement and other security agencies of the government and such other information as the Parties shall mutually agree).

4 Obligations of the Parties

4.1 Obligations of the Customer

15. The Customer is at all times fully responsible for ordering on his behalf, according to the WBA VDSL2 Offer, the WBA VDSL2 services required to support the Wholesale Multicast Services as specified in Annex 2 “Technical Specifications” of the MULTICAST Offer (i.e. the connectivity from the User premises up to the demarcation point between Belgacom network and Customer network), prior to the ordering of Wholesale Multicast Services.
16. The Customer is also responsible for the following:
 - To inform Belgacom immediately and in writing of any change that may have an impact on the Belgacom network and equipments (including the Belgacom IPTV Platform) integrity, or on the performance of other services delivered by Belgacom towards End-Users. The present rule does not imply that such changes can be made by the Customer independently;
 - To use the Belgacom network and equipments (including the Belgacom IPTV Platform) in conformity with the prevailing regulations on telecommunications and data protection and in conformity with the applicable law in general and especially the normal behaviour of a professional Customer;
 - To ensure that his Users behave in a manner that is fully compatible with these elements and take also responsibility for such behaviour;
 - To comply with the instructions that Belgacom may issue to the Customer from time to time to ensure the security and correct operation of the Belgacom network and equipments (including the Belgacom IPTV Platform).
17. In respect of the necessary interventions of Belgacom, the Customer will communicate in good faith to Belgacom, in relevant cases and in a sufficiently timely and complete manner, all information needed by Belgacom for performing repair on the deliverables set up in the frame of the MULTICAST Offer. Customer may refuse to communicate confidential data for which Customer motivates it is not relevant for the requested purpose. Belgacom may ask to BIPT the communication of this data if Belgacom is able to prove his need to obtain this information.
18. In respect of the offering of an IPTV Product to his Users based on a Wholesale Multicast Service delivered by Belgacom pursuant to the provisions of the Contract, Customer is responsible:
 - To seek and take all the prior arrangements with the Right holders to authorize and enable Belgacom to act as the technical facility on behalf of Customer in the framework of the Contract(s); this means for example that the Customer shall be responsible for obtaining all and any authorisation from the Right holders to allow Belgacom to lawfully use the signal and/or encrypted content that Belgacom has received to execute its own distribution activities, and for which the Customer has requested the activation by provision of encryption keys, in order to carry on the technical facilities missions arising from the delivery of Wholesale Multicast Services on behalf of the Customer;
 - For acquiring all appropriate intellectual property rights and authorisations regarding the content used in the context of delivering Wholesale Multicast Services to Customer; Customer guarantees that he is duly authorised by the Right holders to use the content for which he has requested from Belgacom to make the signal available;
 - To obtain commitment from these content providers that they will not cut the signal of the Shared TV channel concerned towards Belgacom because of non compliance by Customer of his obligations in the contract with the content provider;
 - Customer shall bring proof of these authorisations at the moment of Request for activation of the shared TV channel(s) concerned, and later during implementation of the Contract, at the request of Belgacom;
 - To maintain these authorisations for the duration of the Contract(s), and make sure that these authorisations are updated in conformity with any change in the Wholesale Multicast Services;

- To communicate to Belgacom orders for the activation of a minimum set of Shared TV channels (see Main body, “Start-up Pack”), and additional Shared TV channels as desired, corresponding to the provision of the encryption keys related to the requested channels, as well as orders for related services, such as for example the necessary interface configuration for enabling the provisioning of encryption keys (see details in Annex 3 “Planning & Operations”);
- In order to make use of the encryption keys of Belgacom the Customer must foresee an environment which is compatible with the content protection system deployed by Belgacom, i.e. Verimatrix (see Annex 2 “Technical Specifications”);
- To communicate to Belgacom orders for the activation of the multicast functionality on the WBA VDSL2 line of the User(s); these orders will only be accepted if the Customer orders and maintains the activation of a minimum set of Shared TV channels (see Main body, “Start-up Pack”);
- To communicate to Belgacom, as an option on the orders for the activation of Shared TV channels, orders for the provisioning of Dedicated Capacity (within the limitations set forth in “2 Technical Specifications”) enabling the Customer to inject his Dedicated Multicast Streams in the Belgacom network, as well as orders for related services, such as for example the necessary interface configuration for enabling the injection of Dedicated Multicast Streams;
- To communicate to Belgacom an optional order for an interface configuration enabling the Customer to receive, simultaneously, all the encrypted Shared TV Channels which have been activated on his behalf; to ensure that these signals are only used to offer additional services to his Users in support of the Wholesale Multicast Services and are transported via the WBA VDSL2 line of the User;
- To ensure accurate communication of Users’ information to Belgacom in accordance with the relevant provisions of the Contract;
- To ensure the marketing, selling, distribution of his own IPTV Products in conformity with the present Terms and Conditions, as well as the billing and collection of the fees to be charged to his Users, without this affecting the Customer’s liability towards Belgacom;
- To inform Belgacom upfront when a Customer’s User intends to resell to or otherwise put the Wholesale Multicast Services at the disposal of a third party, so that the correct fees for the use of Shared TV channels can be applied (see Annex 5 “Pricing and Billing”);
- To communicate Wholesale Multicast Service related problems to Belgacom; however, to ensure that first all appropriate investigations on User, Customer and broadcaster side have been carried out before raising an issue towards Belgacom;
- To handle responsibility related to network, equipment or signal issues that aren’t related to Belgacom;
- To be the single and only point of contact of his Users with regard to the IPTV Products offered by the Customer to his Users, and abstain from redirecting this User towards Belgacom in any circumstance for any problem related to the IPTV Products or the Wholesale Multicast Services;
- To ensure that his Users cannot receive more multicast streams than their respective User line profile allows;
- To ensure that the total volume of Dedicated Multicast Streams injected by the Customer in the Belgacom network is in accordance with the limitations set forth in Annex 2 “Technical Specifications”; any volume exceeding these limitations will be dropped by the Belgacom network;
- To use the Wholesale Multicast Services, including Dedicated Capacity, only for the offering of IPTV Products;
- To ensure by the Customer, or to have the latter impose on his Users, to use a Decoder which is compliant with the requirements in Annex 2 “Technical Specifications” of the MULTICAST Offer;
- To pay to Belgacom the prices pursuant to the Contract.

4.2 Obligations of Belgacom

19. Belgacom will accept the Order and provide the Wholesale Multicast Services, as described in the MULTICAST Offer, insofar the conditions and limitations described in the present General Terms and Conditions and the MULTICAST Offer are respected.
20. For instance, Belgacom reserves the right to reject a particular Order of the Customer:
 - If Belgacom has determined that a specific User line does not fulfill the appropriate technical requirements (see Annex 2 “Technical Specifications”: e.g. VDSL2 technology, service quality P3 configured on the line);
 - The Customer has not submitted an appropriate order form/request in conformity with the rules described in the Annex 3 “Planning & Operations”;

- The Wholesale Multicast Services ordered are not technically feasible over existing facilities; e.g. there is no free capacity left for injection of Dedicated Multicast Streams in the Belgacom network (see limitations described in Annex 2 “Technical Specifications”);
- The Request for implementation of Wholesale Multicast Services is based on wrong data which do not allow Belgacom to identify the Request or User line unmistakably and provide the Wholesale Multicast Service.

In such cases, Belgacom will communicate to the Customer the reason why the Order/Request has been rejected.

21. Belgacom will provide and maintain the IPTV Platform on behalf of the Customer as regards the Customer’s access to Shared TV channels. In this respect, Belgacom and Belgacom only will be entitled to carry out physical modifications to the Belgacom network or equipments.
22. Belgacom shall respect all service levels, timers and other guarantees mentioned in the Multicast Service Level Agreement, or otherwise shall conform to the applicable penalties.
23. Belgacom is master of its TV channels portfolio. This means that Belgacom is free to add and/or stop the distribution of specific Shared TV channels at its own discretion, in conformity with its retail offer. This means also that Belgacom is entitled to not include certain TV channels in the Shared TV channels Pool under the MULTICAST Offer, and to reserve the distribution of these TV channels exclusively to its retail customers because Belgacom is the editor of the TV channel or has acquired exclusivity rights on the distribution of these TV channels.
24. In the event Belgacom decides to stop the distribution of a specific Shared TV channel, the signal concerned will no longer be available; the Customer who wishes to continue using the signal can decide to inject this signal in the Belgacom network via his own IPTV Platform as part of his Dedicated Capacity (subject to the limitations described in “ 2 Technical Specifications”). Belgacom will inform the Customer, who had access to this signal, with at least 2 months prior written notice of its termination.
25. In the event Belgacom decides to add the distribution of a specific Shared TV channel, the Customer will be informed with at least 2 months prior written notice of the date upon which such signal becomes available to Belgacom’s retail customers, subject to the signature of a non-disclosure agreement.
26. Belgacom will provide the Customer with the encryption keys related to the requested Shared TV channels. Belgacom grants the Customer the right to use, copy and distribute these encryption keys for installation on the decoder of his Users who are end-user of the Customer’s IPTV Product. When a Customer’s User intends to resell or otherwise provide access to the Shared TV channel to a third party, Customer will inform Belgacom, who will, upon explicit request of the Customer, extend the usage right of Customer with a right to use, copy and distribute the relevant encryption keys for installation on the decoder of the end-users of the User concerned, subject to the payment by Customer of the correct fees for the reselling of Shared TV channels (see Annex 5 “Pricing and Billing”).
27. Belgacom has subscribed to and has implemented a content protection system provided by Verimatrix which offers a state of the art solution, as recognized and accepted by the Customer. To avoid any misunderstanding, in no case, Belgacom shall be held liable if the content protection system implemented by Belgacom would fail to perform the functions such technologies were designed to perform and consequently shows some inefficiency to protect the content.

5 Financial Conditions

5.1 Billing and Payments

28. In consideration for the Wholesale Multicast Services provided by Belgacom under the Contract, Customer shall pay the charges and fees provided in the MULTICAST Offer.

5.2 Financial Guarantees

5.2.1 General Principle - Pre-payment

29. Notwithstanding anything to the contrary in the Contract, in order to guarantee the payment by the Customer of the prices due for Services provided by Belgacom that are invoiced on a monthly basis under the Contract, the Customer will provide Belgacom with a monthly pre-payment based on the average of the monthly amount due by the Customer. The amount of the pre-payment shall be based on the average of the invoices issued by Belgacom during three months for the Services ordered in accordance with the Contract. The amount of the pre-payment shall be reviewed every three months. The terms and conditions of this prepayment are described in Annex 6 “Prepayment Terms and Conditions”.
30. In addition, the customer will provide an additional guarantee equal to two months of pre payment. Belgacom reserves the right to require from the Customer the immediate adaptation of this additional guarantee at any time if and when the amount of the monthly prepayment increases.
31. Without prejudice to any other legal or contractual remedies and notwithstanding anything to the contrary in the Contract, in the event Customer fails to pay in due time any undisputed amount due under the pre-payment conditions as defined in the present section and in Annex 6 “Prepayment Terms and Conditions”, Belgacom shall be entitled to execute the following alternatives until full payment is made:
- suspension of any SLA obligations;
 - refusal in writing of any new Order;
 - suspension of the existing Services in accordance with article 822 hereafter.

5.2.2 Sufficient Creditworthiness

32. This monthly pre-payment will not be required in the following circumstances.
33. The Customer has sufficient creditworthiness as evidenced by either of the following alternatives:
- the Customer has obtained a “Ba2” rating or above for its debt (Moody’s); or
 - the Customer has obtained a rating similar to Moody’s “Ba2” rating, provided that (i) such rating is generally accepted by the market as giving similar reliability as Moody’s, (ii) such rating is reviewed and updated on a regular basis.

34. In the event that the Customer would lose the above described creditworthiness at some point in time (either through the loss of “Ba2” credit rating or similar, or upon the occurrence of any default or delay of payment), Customer will have to provide Belgacom with a pre-payment or with another financial guarantee as defined in the present chapter within 10 working days of Belgacom’s request thereto.

5.2.3 Other Financial Guarantees

35. The Customer obtains an irrevocable and unconditional parent corporation guarantee for the debts incurred by the Customer for the Services ordered in accordance with the Contract provided that such parent company is issued by a company that has sufficient creditworthiness as defined above. In the event that the Parent Company would lose the above described credit worthiness at some point in time, the Customer will provide Belgacom with a pre-payment or with another financial guarantee as described in the present article within 10 working days of the request of Belgacom.
36. The Customer has constituted a Deposit on an escrow account with a reputable bank or financial institution established in the EU. The amount of that deposit will be equal to an estimate of three months of invoices due by the Customer for the Services ordered in accordance with the Contract. Based on the actual evolution of the amounts due for the Services, the Customer and Belgacom will have the right to require an adaptation of the amount of the deposit every three months. Upon the request for adaptation of the amount of deposit, necessary steps will be taken to ensure adaptation within ten (10) working days. In case of default by the Customer to pay sums due under the Contract, the sums deposited on the escrow account will accrue to Belgacom. The interests accrued on the escrow account will be payable to the Customer. In the event the sums deposited are accrued to Belgacom, or if the amount of the deposit is not adapted despite Belgacom’s request thereto, Customer will provide Belgacom with a pre-payment or with another financial guarantee as defined in the present article within 10 working days of the request of Belgacom.
37. The Customer has provided Belgacom with a irrevocable and unconditional bank guarantee on first demand issued by a reputable bank or financial institution established in the EU. That bank guarantee will be issued for a minimum period of three years and for an amount equal to an estimate of three months of amounts due by the Customer for the Services ordered in accordance with the Contract. Based on the evolution of the amounts due for the Services, Customer and Belgacom will have the right to require an adaptation of the amount of the bank guarantee every three months. Upon the request for adaptation of the amount of bank guarantee, necessary steps will be taken to ensure adaptation within ten (10) working days. Upon expiration of the bank guarantee or after Belgacom has called upon the bank guarantee, or if the amount of the bank guarantee is not adapted despite Belgacom’s request thereto, the Customer shall provide Belgacom with a pre-payment or with another financial guarantee as defined in the present article within 10 working days of the request of Belgacom.
38. The type of Financial Guarantee, which shall be provided by the Customer prior to submitting his Request for a Service, will be agreed upon between Parties and indicated in a formal confirmation letter signed between Parties.

6 Principles

6.1 Retail Pricing & Billing

39. Customer shall be responsible for the setting of the tariffs that Customer will apply to the Users to whom Customer will sell an IPTV Product based on the Wholesale Multicast Services, as well as for the billing and invoicing of such Users.
40. No deductions or reductions shall be made from the payment of any charges or fees due for the Services for any bad or unpaid debts or any unrecoverable claims (including, in particular, claims arising from fraud cases) that Customer may have against his Users or any other third parties in relation with these Services.

6.2 Branding

41. The Parties agree not to offer any service under any brand, including any trademark, trade name or company name, of the other Party unless the use of the brand(s) of the other Party is explicitly provided under the Contract. Such use of the brand will then be strictly limited to the service at stake.
42. Customer shall offer IPTV Products to Users under his own brand without any use of, or reference to Belgacom's brands.

6.3 User Terms and Conditions

43. Customer shall cause the terms and conditions governing Customer's contractual relationships with the Users to be compliant with the rules and principles set out in the MULTICAST Offer. Notwithstanding the above, nothing in the present Reference Offer can be construed as creating or evidencing a contractual relationship of any kind between Belgacom and Customer's Users or as providing to Belgacom any right to consult the contracts signed between Customer and his Users.
44. Customer shall indemnify Belgacom against all losses, claims or liability suffered by Belgacom due to the fact that Customer will have failed to incorporate the above mentioned rules and principles in his terms and conditions.

7 Coordination between the Parties

7.1 Single Points of Contact

45. Each of the Parties will both appoint an individual as its respective single point of contact (“SPOC”) who will act, within the organization of such Party, as the other Party’s contact person.
46. The SPOC of either Party will have full authority to act and decide on behalf of the respective Party on all technical and operational matters regarding the day-to-day management of the performance of their Multicast Contracts. All the decisions taken by any working group constituted by the Parties during the performance of this Multicast Contracts will need to be expressly and formally validated by the SPOC of either Party to be binding on such Party. Except as otherwise expressly provided by the relevant Party, each Party’s SPOC will have no authority to modify the conditions described in the Contract, or to act outside the day-to-day management of the performance of the Services.
47. Notwithstanding anything to the contrary in the foregoing, each Party will be authorized to replace its SPOC by notice sent to the other Party. Such notice will have immediate effect.

7.2 Working Group

48. The Parties will be free to set up any other working group in charge of discussing and agreeing on any technical or operational issue as the Parties may deem fit in the performance of the Services.

8 Liability

8.1 General rules

49. Taking into account the nature of the respective activities of the Parties, the risks and potential profits associated with these activities and the consideration obtained by each Party from the Contract, Parties expressly agree that their respective liability shall be limited as follows.
50. If either Party is held liable to the other Party under the Contract, that liability shall be limited to the following:
 - if such liability results from any personal injury or death incurred as a direct result of the non-performance of the relevant Party's obligations under the Contract, then such liability shall be only subject to the limitation provided in article 51;
 - if such liability results from any conduct attributable to the relevant Party, which is, under Belgian law, characterized as being gross negligence (*faute lourde – zware fout*) or intentional negligence (*dol – bedrog*), then such liability shall be subject to no limitation, except as permitted by law;
 - if such liability results from any material damage (including any dysfunction of the Belgacom's Network), other than those referred to above, arising out of or in any way connected with the performance by the relevant Party of the Services or the breach of such Party's obligations under these Terms and Conditions, then the total amount which can be recovered from such Party for all acts or omissions shall, in no event, exceed an aggregate amount equal to EUR 1,250,000 (one million two hundred fifty thousand euro), subject to the limitation provided in article 51.
51. Neither Party shall be liable for indirect damages (pure and consequential), including without limitation loss of profit, loss of revenue, loss of data, loss of use, loss of savings, loss of goodwill, interruption of business or claim by third parties.

8.2 Specific rules

52. Customer will indemnify Belgacom against any claim or loss related to the illegal use, or the use for illegal purpose of the Wholesale Multicast Services by Customer, Customer's Users or by any person using the Wholesale Multicast Services.
53. Customer will indemnify Belgacom for any damage that the use of the Wholesale Multicast Services by the Customer, Customer's Users or by any person using the Wholesale Multicast Services would cause for Belgacom, its customers, or the functioning of its network and equipments (including the Belgacom IPTV Platform).
54. Belgacom is not responsible for the use made by the Customer or his Users of the encryption keys provided by Belgacom. Customer will indemnify Belgacom from any claim by any third party (including competent authorities or any Right holders) related to the use made of the encryption keys.
55. Customer recognises and accepts that Belgacom shall only act as a technical facility ('mere conduit') for handling/supplying the content/signal requested by the Customer. The Customer acknowledges that Belgacom shall not be held responsible for any claim by any third party (including competent authorities or any Right holders) related to the use, transmission or manipulation of the content/signal when delivering the Wholesale Multicast Services. The Customer shall hold Belgacom harmless from any such claim and indemnify Belgacom for any costs or damages it has incurred following such claim.
56. Customer will also indemnify Belgacom from any claim by any third party (including Right holders or Users of Customer) following the termination of the offering of a particular Shared TV channel/signal.

57. Customer recognises and accepts that Belgacom is not responsible for the quality of the signal of the Shared TV channel, except for the formatting of the broadcaster's signal (i.e. decryption and decoding of the broadcaster's signal, encoding according to the video standard and encryption of the signal by Belgacom). Customer will forward a direct claim towards the broadcaster in case of problems related to the distribution or quality of the signal, which do not fall under the responsibility of Belgacom.

Belgacom is not responsible for signal deficiency or loss at broadcaster side, for instance in following events:

- for all channels : loss of play-out, corrupted contribution source, unannounced changes in broadcaster's feed definition/encoding/encryption, loss of power at broadcaster location;
- for international channels : uplink/downlink or terrestrial broadcaster's feed contribution problems, no decryption rights renewal due to broadcaster, unannounced broadcaster's encryption/feed changes.

Moreover, Customer recognises and accepts that Belgacom cannot be held liable in case of a temporary reduction in quality, a weak transmission or a temporary degradation of the transmitted signal.

If Belgacom is informed the signal is interrupted or suspended or if there is a significant degradation in the quality of sound and/or image of the channel, Belgacom shall take the measures which are within its control and which it deems reasonable and necessary to resolve the problem as soon as possible, provided the problem has its source within Belgacom's control and responsibility. Until the problem is solved, Belgacom shall insert a static or other type of image to inform the User of the issue.

8.3 Force Majeure

58. Neither Party will be liable for any delay or failure to fulfil its obligations under the Contract arising from any event beyond its reasonable control, such as for instance but without limitation: natural disasters (e.g. fire, flooding, earthquake), weather conditions (e.g. heavy rain, thunderstorms, snow, sun interference), strikes or intervention by a third party who does not act under the responsibility of that Party (e.g. looting, rioting, sabotage, unauthorised handling of Belgacom equipments or cabling by broadcasters at broadcaster location), all such events being hereafter referred to as "Force Majeure".
59. The Party claiming Force Majeure shall as soon as possible send to the other Party a Notice of the Force Majeure. Such Notice shall contain adequate evidence of the occurrence and extent of the Force Majeure, as well as an estimate of the expected duration of the Force Majeure. As soon as practicable after receipt of such Notice, the Parties shall consult with each other in order to find an equitable solution to the problems and difficulties caused by the Force Majeure.
60. The Party claiming Force Majeure shall use all reasonable endeavours to minimise the consequences of such Force Majeure, and to ensure, in as far as reasonably possible, the continuity of the services provided under the Contract and shall perform those of its obligations not affected by a Force Majeure. To the extent that a Party is prevented as a result of Force Majeure from providing one or several of the services or facilities to be provided under the Contract, the other Party shall be released to the equivalent extent from its obligations to make payment for such services or facilities or complying with its obligations in relation thereto.
61. Upon cessation of the effects of the Force Majeure, the Party initially affected by such Force Majeure shall promptly notify the other Party of such cessation.

8.4 Accidents at work and Safety Rules

62. Each Party hereby undertakes to provide insurance cover against accidents at work for its own employees in conformity with the applicable legal requirements. Each Party hereby renounces any possible claim against the other Party, and undertakes to procure that its insurer shall not pursue against the other Party, or against any third party for whose acts or omissions the other Party may be responsible, any claim relating to accidents at work.



63. Each Party shall comply with safety practices and procedures reasonably applicable when entering the premises and installations of the other Party in order to carry out work. Each Party undertakes to ensure that its personnel or its subcontractor personnel, while upon the premises and installations of the other Party, will respect any internal rules and codes of conduct therein applicable, provided that such rules and/or codes shall have been made available to them in advance. Without prejudice to the provisions of the chapter relating to Liability, each Party shall indemnify and hold harmless the other Party for any and all damages, costs or expenses incurred as a result of any act or omission of a Party's personnel or a Party's subcontractor personnel while upon the premises and installations of the other Party.

9 Operational Matters and Network Management

64. The Wholesale Multicast Services provided under the Contract shall be implemented and provided by the Parties in accordance with the technical specifications set forth in the Annex 2 “Technical Specifications” and the operational rules and procedures contained in the Annex 3 “Planning and Operations”.
65. Both Parties shall cooperate to install and maintain reliable services. Both Parties shall exchange appropriate information as provided in the Annex 3 “Planning and Operations” (including in particular, maintenance contact number, networks information, information required to comply with law enforcement and other security agencies of the government and such other information shall mutually agree) to achieve this desired reliability.
66. Each Party shall apply sound network management principles by invoking network management controls to ease the operation of their respective systems and to alleviate or to prevent congestion. In particular, Belgacom will control that the total volume of Dedicated Multicast Streams injected by the Customer in the Belgacom network does not exceed the limitations set forth in Annex 2.
67. The Parties shall ensure that the Essential Requirements, as defined and applicable under the regulatory framework, are adequately and sufficiently protected, in as far as the establishment, maintenance and operation of the Services offered under the Contract are concerned.
68. It is a condition for the provision by Belgacom of the Wholesale Multicast Services under the MULTICAST Offer that Customer’s Request is not detrimental to the operation of the Belgacom network and equipments (including the Belgacom IPTV Platform) and telecommunications services (including Belgacom TV services) or to their integrity or interoperability, and that the protection of service and internal data, network equipment, software and stored data, including personal data, confidential information and privacy can be sustained.
69. The conditions for and restrictions on use applying at any time appear from the Annex 2 “Technical specifications”.
70. Belgacom shall further be entitled to cause interruptions, disturbances or modifications of Belgacom’s network, equipments (including the Belgacom IPTV Platform) and Wholesale Multicast Services to the detriment of the supply of the Services under the Contract in connection with measures that are deemed necessary for technical, maintenance, development and operating reasons taking into account the balance of the interests of both Parties or, that are ordered by the regulatory authorities. Belgacom shall give in good faith Customer the longest possible notice of interruptions, disturbances and modifications, by any means it deems appropriate (e.g. via electronic communication) and state the reason for them.

10 Amendments and Revisions

10.1 General Principles

71. Except as otherwise provided in the MULTICAST Offer, any agreement departing from the Contract or its Annexes shall only be valid if duly agreed upon in writing by the respective representatives of the Parties.

11 Termination and Suspension

72. Customer has the right to terminate one or more Contracts as provided in the MULTICAST Offer. Belgacom has the right to terminate one or more Contracts in order to preserve Belgacom's network integrity and security, and for other particular reasons as listed below.
73. Without prejudice to the above, the Wholesale Multicast Services and related Contract(s) are automatically terminated when the necessary, underlying WBA VDSL2 services are cancelled for any reason.
74. A Multicast Contract shall automatically be terminated without prior notice to Customer upon the activation by Belgacom of another service (broadband service, possibly in combination with a TV solution) on the same line based on the valid migration request of either Belgacom retail or another Customer. Belgacom will further inform Customer of the new request without revealing the identity of the latter.
75. Belgacom will have the right to terminate the activation of the multicast functionality on the WBA VDSL2 line of each User when the Customer cancels the activation of the minimum set of Shared TV channels (see Main body, "Start-up Pack").
76. Belgacom will have the right to suspend or terminate access for the Customer and his Users to a particular Shared TV channel, at the written request of the content provider concerned. Belgacom will inform Customer as soon as possible of the cause of such suspension/termination.
77. Belgacom will have the right to stop the distribution of a signal of a specific Shared TV channel for its retail services, in which event the signal shall also be terminated for the Customer. In conformity with article 24 above, Belgacom will inform the Customer, who had access to this signal, with at least 2 months prior written notice of its termination.
78. The Customer is required to terminate the Contract related to the access to a particular Shared TV signal, as soon as his authorisations/intellectual property rights related to the content concerned have expired.
79. In the event Customer uses or allows the use of Services provided under the Contract in an illegal manner or for illegal purposes (such as for instance but without limitation: violation of intellectual property rights of third parties), or if Customer by its action or omission causes, or could reasonably be expected to cause a damage to the working or the security of the Belgacom network and equipments (including Belgacom IPTV platform), and Customer fails to take appropriate measures in order to remedy to the situation within a period of fifteen (15) days from the receipt of a Notice of Suspension sent by Belgacom, Belgacom will have the right to suspend the provision of some or all of the Wholesale Multicast Services. Notwithstanding the foregoing, Belgacom will have the right to take proactive actions prior to sending the above mentioned Notice in urgent cases where actions of Customer disturb the quality of the Shared TV signal and/or the stability of the Belgacom IPTV platform. In that case, Belgacom will inform the parties involved about the actions taken at the latest 24 hours after the suspension.
80. If the Customer uses or allows the use of Services provided under the Contract in a manner not corresponding to the Technical Specifications set forth in the Annex 2 "Technical Specifications", and Customer fails to take appropriate measures in order to remedy to the situation within a period of fifteen (15) days from the receipt of a Notice sent by Belgacom, Belgacom reserves the right to suspend all or some of the Services.
81. Belgacom will have the right to suspend or terminate Wholesale Multicast Services in the event that it is requested to do so by an order of a court or a competent authority. Belgacom will inform Customer as soon as possible of the cause of such suspension/termination.

82. Without prejudice to article 31, in the event that Customer fails to pay an outstanding invoice (invoice, pre-invoice or final invoice) for any amount due under the MULTICAST Offer, Belgacom shall be entitled, after having duly informed the BIPT,
- to suspend all Wholesale Multicast Services (entirely or partially, including suspension of any SLA obligations and refusal of any new Order) without further notice if the total amount due has not been paid within a period of fifteen (15) days following written Notice;
 - to terminate all Wholesale Multicast Services without further notice if the default is not cured within a period of 30 days following the same Notice.
83. Article 82 does not apply to amounts duly disputed by the Customer in writing, before the Due Date, including a clear summary of the grounds for the Dispute and the position of the Customer as to this dispute.
84. In the event that Customer fails to provide, renew, adapt or reconstitute the financial guarantee as provided in the chapter on Financial Guarantee here above, Belgacom shall be entitled, after having duly informed the BIPT,
- to suspend all Wholesale Multicast Services (entirely or partially, including suspension of any SLA obligations and refusal of any new Order) without further notice if the default is not cured within a period of 15 days following written Notice;
 - to terminate all Wholesale Multicast Services without further notice if the default is not cured within a period of 30 days following the same Notice.
85. The provisions of this chapter on suspension of the Services and termination of the Contract(s) are without prejudice to any other right or claim for compensation to which the non-defaulting Party may be entitled to in the event of suspension of one or more Services or termination of one or more Contracts, whatever is the case.
86. In the event of suspension or termination of one or more Services, Customer will be responsible to inform the relevant Users of the consequences of the suspension or termination of the Contract(s) in a neutral manner.
87. The Contract(s) are concluded on condition subsequent of termination in the event that either Party is declared bankrupt, ceases its business activities or enters into liquidation. In such event, the other Party may terminate all the Wholesale Multicast Services, without any further legal or other procedures, by sending notice of termination with immediate effect to the other Party.
88. In the case of termination of the Services for any reason, Belgacom shall be entitled to payment for all Services performed prior to such termination in accordance with the conditions that were applicable between the Parties at the time of termination.
89. The provisions of the Contract which by their nature are determined to survive the termination of the Contract (including, in particular but without limitation, the provisions on Confidentiality and Applicable Law and Jurisdiction) shall remain in full force and effect after the termination.

12 Confidentiality

12.1 Confidential Information

90. For the purpose of this Chapter, the term “Confidential Information” shall mean:
- information communicated by one Party (or from any of its Associated Companies) (the “Disclosing Party”) to the other Party (or to its employees and advisors) (the “Receiving Party”), or obtained by the Receiving Party in connection with the performance of the Services, provided that such information is, at the time of its disclosure, reasonably designated "confidential" or with an equivalent term. If such information was disclosed orally, it shall constitute Confidential Information provided that the Disclosing Party informs the other Party at the time of such disclosure, that such information is confidential and that (i) a written notice containing a summary of the information disclosed orally and mentioning that such information is confidential, is issued by the Disclosing Party to the other within five Working Days from the date of disclosure, or (ii) such disclosure is recorded in minutes of a meeting that are designated, labelled or marked "confidential" or designated, labelled or marked with an equivalent term.
 - Shall in any event be considered as Confidential Information, any information regarding the usage (new adding or termination) of TV channels by any Party before its commercial launch or communication to the public.
91. For purposes of these General Terms and Conditions, "Confidential Information" does not include:
- information that is properly and lawfully in the public domain otherwise than by breach of the Contract or any other obligation of confidence;
 - information that was disclosed by a third party to the Receiving Party without restriction on disclosure or use, unless the Receiving Party knew or should reasonably have known that this information was acquired unlawfully or by a breach of contract or fiduciary relationship.
92. Except as specified in writing, by the Disclosing Party at the time of disclosure, Confidential Information shall continue to be deemed as such until the end of a period of three (3) years after its initial communication under the Contract.

12.2 Non-Disclosure

93. The Receiving Party shall refrain from disclosing the Confidential Information to any third party and shall use the Confidential Information only for the performance of the Services offered in accordance with the Contract. In addition, the Receiving Party shall take any reasonable measures to ensure the confidentiality of this information. In any event, the Receiving Party shall use efforts at least commensurate with those that such Party uses for protecting the confidentiality of its own Confidential Information.
94. Notwithstanding the foregoing and without prejudice to the provisions regarding the Disclosure to Personnel, Advisors, Suppliers or Resellers here-under, either Party shall be allowed to disclose the Confidential Information to third parties provided it has obtained the prior written consent of the other Party. Such written consent will be given case-by-case upon a discretionary basis. Such written consent shall only be valid and enforceable for the specific information listed therein. The written consent to disclose Confidential Information shall identify the third party or parties to which the information can be disclosed and shall set forth the terms and conditions to which such disclosure is subject.
95. The Disclosing Party shall remain free to disclose to any third party Confidential Information disclosed to the Receiving Party.

12.3 Disclosure to Personnel, Advisors, Suppliers or Resellers

96. A Receiving Party shall disclose the Confidential Information received from the other only to its directors, employees, suppliers, agents, advisors, contractors, sub-contractors, or resellers who have a need to know such information. Such Party shall ensure that such directors, employees, suppliers, agents, advisors, contractors, sub-contractors or resellers are bound by the obligations of confidentiality in respect of the Confidential Information, which is at least equivalent to the confidentiality obligation set forth in the Contract.
97. Notwithstanding anything to the contrary in the foregoing provisions, the Receiving Party shall not disclose or use the Confidential Information, with the aim of providing commercial advantage to business divisions of the Receiving Party, or business divisions of the Receiving Party's Associated Companies, which are engaged in activities competing with the other Party.
98. Each Party shall be liable under the limitations provided in the Chapter relating to Liability here-above, for any unauthorized disclosure or use of the Confidential Information by its directors, employees, suppliers, agents, advisors, contractors or subcontractors. The Party responsible for an unauthorized disclosure or use of the Confidential Information shall, in any event, take any reasonable measures (including but not limited to court proceedings) to mitigate the damage resulting there-from.

12.4 Disclosure Required by Law

99. If the disclosure of Confidential Information to third parties is required by reason of legal, accounting or regulatory requirements beyond the control of the Receiving Party, the Receiving Party may disclose such information to the extent necessary to comply with such requirements. Without prejudice to the application of the foregoing, the Parties shall endeavour to ensure the confidential treatment of the Confidential Information by the third parties receiving such information as a result of such requirement.
100. Without limitation to the generality of the foregoing, either Party will have the right to disclose Confidential Information to the BIPT, whenever required by law, or deemed reasonably necessary in the context of any proceedings or discussions held in front or with the BIPT. If any such disclosure of Confidential Information is made, the Party communicating the information will ensure that the attention of the BIPT is properly drawn to the fact that the information is confidential and that the information needs to be kept confidential.

13 Dispute Resolution and Applicable Law

13.1 Dispute resolution procedure

101. The SPOC shall, on an ongoing basis, attempt to solve any dispute, controversy or claim between the Parties concerning the interpretation, application and implementation of the present General Terms and Conditions and/or the Contract and its Annexes (a “Dispute”) through discussions held in good faith.
102. In the event that the Parties have been unable to solve any Dispute, then upon Notice of either Party, each of the Parties will appoint a designated senior business executive (other than their respective SPOC) whose task it will be to meet for the purpose of endeavouring to resolve the Dispute. Each Party shall ensure that their respective designated executive has sufficient authority or decision-making power concerning the matter at stake. The designated executives will meet as often as the Parties reasonably deem necessary in order to gather and furnish to the other all information with respect to the matter in issue which the Parties believe to be appropriate in connection with its resolution. Such executives will discuss the Dispute and will negotiate in good faith in an effort to resolve the Dispute without the necessity of any formal proceeding relating thereto.
103. In the event the Parties fail to reach such a solution and/or settlement within fifteen (15) Working Days as from the receipt of the above Notice, they shall escalate the matter to a higher level within their respective organizations. Discussions at that level will be conducted as described in article 102. The Parties may, at any given escalation level, agree to extend the time limits described in this article and in article 102 when they consider it necessary in order to facilitate that an agreement be concluded on the subject-matter of the dispute.
104. Except in the cases of urgency, as determined in good faith by the Party calling the Dispute, and unless otherwise in these general Terms and Conditions, no formal proceedings for the resolution of a Dispute may be started until the earlier to occur of (a) a good faith conclusion by the designated executives that amicable resolution through continued negotiation of the matter in issue does not appear likely or (b) the Parties have failed to reach an agreement on the Dispute within 15 Working Days of the escalation of the Dispute as described in article 102.

13.2 Applicable Law and Jurisdiction

105. The MULTICAST Offer, its Annexes, and the Contract(s) shall be governed by Belgian law.
106. Without prejudice to article 104, any dispute concerning the validity or the interpretation of the MULTICAST Offer and the Contract(s), or the performance of the Wholesale Multicast Services, or of subsequent contracts derived here-from shall be finally submitted to the Courts of Brussels, Belgium. This provision is without prejudice to the right of each of the Parties to submit the dispute to the BIPT with a view to reach conciliation or to submit the dispute to the Competition Council.

14 Miscellaneous

14.1 General Principles

107. All the terms and conditions of this MULTICAST Offer, including its Annexes and/or Appendixes, are agreed upon by the Parties without prejudice to the rights and obligations that either Party may derive from the applicable provisions of the regulatory framework. The fact that either Party has agreed to any provision in this MULTICAST Offer will not be construed as a renunciation by such Party to invoke (i) any right that such Party may derive from any imperative provision of the applicable regulatory framework or (ii) any obligation that may be imposed to the other Party pursuant to any imperative provision of the applicable regulatory framework.
108. In the framework of the MULTICAST Offer, should a conflict arise between the Main Body, and any or several Annexes, attachment or appendix to an Annex, the Main Body shall prevail, except for (a) Annex 1 - General Terms and Conditions, which will prevail over the Main Body unless otherwise specifically stated, (b) when otherwise agreed by the Parties, in writing or (c) when otherwise specifically stated in the Main Body or Annex, Attachment or Appendix. Should a conflict arise between Annex 1 - General Terms and Conditions and another Annex, attachment or an appendix to said other Annex, the Annex 1 - General Terms and Conditions shall prevail unless otherwise specifically stated. Should a conflict arise between an Annex and an attachment or an appendix to this Annex, the Annex shall prevail unless otherwise agreed by the Parties, in writing or otherwise specifically stated.

14.2 Notices – Address for Invoicing

109. Unless stated otherwise in the MULTICAST Offer or its Annexes, any Notice under the Contract(s) will be sent to the respective SPOC of the Parties, in writing and by registered mail or by email (so called “Flash communication” sent by Belgacom to its Customers) to the addresses indicated in a formal confirmation letter signed between Parties. Belgacom shall send the invoices and credit notes by ordinary mail, via email or via CertiOne (see Annex 5 “Pricing and Billing”) to the invoicing address of the Customer indicated in the same confirmation letter.

14.3 No Assignment

110. Neither of the Parties is entitled to assign the Contract, in part or in its entirety, to any third party or to any other entity unless with the prior written approval of the other Party.
111. No approval will be required for an assignment of the Contract in case of transfer to a successor, to which a transfer has taken place of, at least, the Assigning Party’s activities covered by the Contract. In such a case, the assigning Party shall immediately give Notice to the other Party of any such assignment permitted to be made under the Contract without requesting the other Party’s consent.
112. Without prejudice to the foregoing, no assignment shall be valid unless the assignee agrees in writing to be bound by the provisions of the Contract and its Annexes.

14.4 Waiver

113. A failure by either Belgacom or Customer to insist on the performance of any term of the Contract or to exercise any right or privilege hereunder shall not be construed as a continuing or future waiver of such term, condition, right or privilege. No waiver shall be valid unless it is in writing and signed on behalf of the Party making the waiver.

14.5 Fraud

114. The Parties accept to cooperate to the best of their respective abilities in order to prevent and eliminate any kind of fraud which involves Services provided under the Contract. If any of the Parties suspects such kind of fraud, the Parties shall co-operate in order to identify the origin of the fraud and to use any appropriate means in order to eliminate and prevent such fraud as soon as possible. For the purposes of the application of the present provision, fraud shall mean any manipulation of a communications network, including by Customer connected to the network of one of the Parties, in order to obtain one or more telecommunication or IPTV services without paying the proper charge for it, or to support other criminal activities (including, in particular, wiretapping, eavesdropping and gathering secret numbers).
115. It is explicitly acknowledged by the Parties that any cooperation in the context of the present provision will need to be in due compliance with the entire regulatory framework.

14.6 Independent Parties – Approvals

116. Each Party shall be responsible for obtaining and keeping in effect all approvals from, and rights granted by, competent authorities, other operators, and any other persons that may be required in connection with the performance of its obligations under the Contract. Each Party shall reasonably cooperate with the other Party in obtaining and maintaining any required approvals and rights for which other Party is responsible.
117. Each of the Parties is and shall remain at all times an independent contractor. Neither Party is authorized and neither of the Parties nor their employees, agents, representatives or subcontractors shall at any time attempt to act or act on behalf of the other Party to bind the other Party in any manner whatsoever to any obligations. Neither Party nor its employees, agents or representatives shall engage in any acts which may lead any person to believe that such Party is an employee, agent or representative of the other Party. Nothing in the Contract shall be deemed to constitute a partnership between the Parties.

Wholesale Multicast

Annex 2: Technical specifications

Created on: 06 March 2012

belgacom

together with





together
with



1 Table of contents

| | | |
|----------|--|-----------|
| 1 | Table of contents | 2 |
| 2 | Abbreviations | 3 |
| 3 | Scope | 5 |
| 4 | End-to-end view | 6 |
| 5 | UNI..... | 7 |
| 6 | DSLAM Platform | 8 |
| 6.1 | VLAN ID ALLOCATION..... | 8 |
| 6.2 | Multicast configuration | 9 |
| 6.3 | Multicast CAC (Connection Admission Control) on the first mile (DSL line)..... | 9 |
| 6.4 | Customer's User configuration..... | 10 |
| 7 | WBA transport in Belgacom Ethernet network | 11 |
| 7.1 | Multicast ingestion by the Customer | 12 |
| 7.2 | Shared TV Channel interface | 12 |
| 8 | MULTICAST CHANNELS | 13 |
| 8.1 | MPEG 2 Transport Stream..... | 13 |
| 8.2 | IP encapsulation | 14 |
| 8.3 | Layer 2 encapsulation..... | 14 |
| 8.4 | VERIMATRIX ENCRYPTION | 15 |
| 8.5 | Verimatrix Components | 15 |
| 8.5.1 | VCAS™ for IPTV | 15 |
| 8.5.2 | Remote Stream Manager | 15 |
| 8.6 | VPN between the Customer and Belgacom Verimatrix Components | 16 |

2 Abbreviations

| | Description |
|-------|--|
| CAC | Connection Acceptance Control |
| DHCP | Dynamic Host Configuration Protocol |
| DS | Downstream |
| GE | Gigabit Ethernet |
| IPoE | Internet Protocol over Ethernet |
| LACP | Link Aggregation Control Protocol |
| LAG | Link Aggregation |
| LAN | Local Access Network |
| LEX | Local Exchange |
| LTE | Line Termination Equipment |
| MTU | Maximum Transmission Unit |
| OAL | <u>O</u> LO (Ethernet) <u>A</u> ccess <u>L</u> ine |
| OLO | Other Licensed Operator |
| p-bit | Priority bit |
| PoP | Point of Presence |
| PPP | Point to Point Protocol |
| PPPoE | Point to Point Protocol over Ethernet |
| UNI | User Network Interface |
| US | Upstream |
| U2U | User to User (communication) |
| VDSL2 | Very High Speed Digital Subscriber Line 2 (= Ethernet Based, while VDSL1 is ATM based) |



together
with



| | |
|-----------------------|--|
| VLAN WBA VDSL2 | Virtual LAN. Wholesale Broadband Access VDSL2. Here only the types of service: with shared VLAN is concerned, NOT “dedicated VLAN”. |
|-----------------------|--|

3 Scope

1. The purpose of this document is:
 - To describe the technical specifications of the Multicast TV Services. Note that the description of the service is available in the Multicast TV Offer, Main Body.
 - To allow the Operator to setup a service based on this service from Belgacom, describing the interfaces in detail.
2. Multicast TV Services are based on the WBA VDSL2 offer. Only delta's and specific issues are repeated here further.
3. Prerequisite for a Customer willing to offer this service to his end-users in a specific LEX, is to have a WBA VDSL2 shared VLAN "p3" in this LEX.
4. The WBA VDSL2 "with dedicated VLAN" is not compatible with this service, because of the crossconnect type of connectivity in the VDSL2 DSLAM (ISAM), which cannot be combined with the bridged connectivity, required for this multicast service.

4 End-to-end view

5. The User, for whom the Customer has ordered Multicast TV Services, will have access to:
 - Multicast TV channels ingested by his operator in the Belgacom PIM Core network, in a specific way described further, together with other multicast (e.g. STB update) data . Belgacom will allocate to each Customer a dedicated Multicast Group IP address range for this purpose.
 - Shared TV Channels, shared between Belgacom and his operator.
6. Both flows are transported together in the Belgacom PIM Core network and the aggregation networks, up to the VLAN 40 of the WBA VDSL2 User for whom the Customer has ordered Multicast.
7. The TV related unicast to this User, eg Encryption keys, unicast Settop Box management, VOD, Unicast TV,..., shall be transported via the shared VLAN “p3” and will also be delivered via VLAN id 40 on the WBA VDSL2 User line.

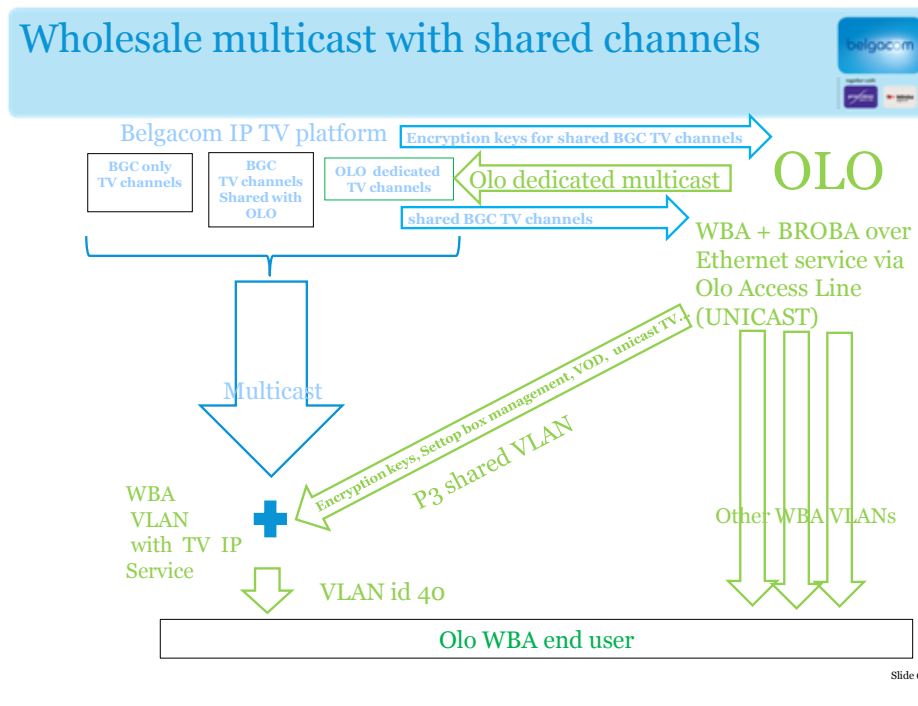

8. The Customer shall obtain encryption keys for the Shared TV channels, agreed with Belgacom and shall distribute them to his Users. These TV Channels are encrypted.

5 UNI

9. The WBA VDSL2 line profiles, according to Belgacom Deployment Rules (WBA VDSL2 Main Body - Section 4.13), are listed in the detailed IT protocol of deliverable 2 regarding VDSL2 OLO CPE for WBA.

6 DSLAM Platform

6.1 VLAN ID ALLOCATION

10. The DSLAM performs two major functions:

- The Customer's User VLAN (VLAN ID 40) is mapped to the Customer's unicast TV VLAN at the uplink with VLAN Translation
- Multiplexing of Customer's unicast TV VLAN and MC VLAN (uplink) to one VLAN (TV unicast/MC) at the subscriber port.

11. On UNI 4 VLANs are foreseen in the WBA VDSL2 Offer. Multicast will be offered on VLAN 40 (p-bit 3). The latter will be translated to the respective Customer NNI VLAN (p-3). VLAN 40 will be connected only to the "P3" shared VLAN. The VLAN 40 will contain P3 unicast and P4 Multicast. On NNI, Belgacom multicast VLAN will be used for multicast on WBA VDSL2 line.

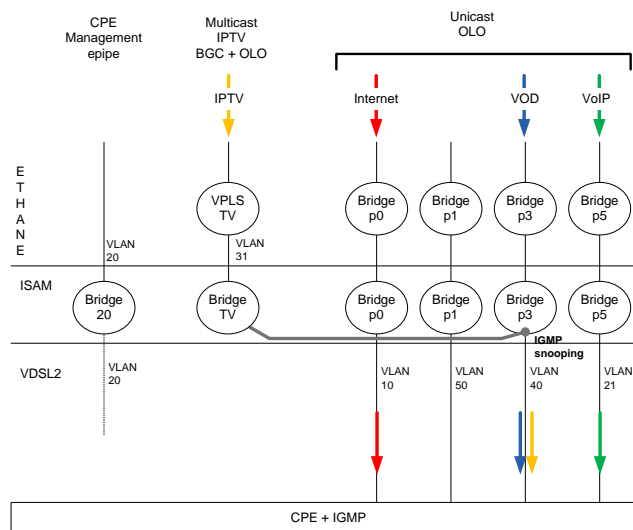

6.2 Multicast configuration

12. All channels (Belgacom Shared TV Channels and the Customer's dedicated multicast streams) are configured with ethernet BW in order to provide multicast CAC on DSL line.
13. Fast leave mechanism is enabled for a multicast stream so the stream is immediately stopped on reception of the leave message if no other users on that line have joined the same stream.
14. IGMP system parameters
 - IGMP proxy. The source IP@ of the IGMP proxy function: 195.13.31.34
 - IGMPv3 with backward compatibility towards IGMPv2.
 - IGMP default system parameters

| Parameter | Value |
|-----------------------------|-------|
| Robustness | 2 |
| Query interval | 125s |
| Query maximum response time | 10s |

6.3 Multicast CAC (Connection Admission Control) on the first mile (DSL line)

15. Each multicast group is configured at DSLAM level with their respective bandwidth. The latter is expressed as Ethernet BW and corresponds to the peak rate.
16. Upon every IGMP join request, the bandwidth of the requested multicast stream is checked with the available bandwidth on the DSL line. If the available BW is lower than the BW of the requested multicast stream and the stream would still be forwarded towards the User, all services of the User would be impacted.
17. The available multicast bandwidth is derived from the Actual Line Rate (ALR) and the EFM overhead. The Ethernet EFM overhead factor is used to calculate EFM bandwidth required by streams for which bandwidth parameters are specified as Ethernet bandwidth. A typical overhead of 3% for EFM encapsulation is configured at system level.
18. Formula applied in order to calculate the available bandwidth (BW) on DSL line:

$$\text{Available BW} = (\text{Actual Line Rate (ALR)} * 97\%) - (\text{sum of configured bandwidth for the multicast groups currently received})$$

19. On the line there is no portion reserved for voice and data. Only multicast traffic is controlled by the CAC functionality.

20. Formula applied in order to allow a connection (join):

Configured bandwidth of new stream \leq available BW

21. The CAC on DSL is enabled at system level.

6.4 Customer's User configuration

22. IGMP control channel on VLAN 40

23. Dsl ctrl pkt policer: Policer for control traffic like IGMP (/DHCP/PADx messages/802.1x...) aligned with Belgacom implementation (~ 16 messages/s).

24. BW CAC on DSL line: CAC profiles are used primarily for multicast video admission control.

25. Limitation of the maximum number of multicast channels per DSL line aligned with BELGACOM implementation. At present limitation is set to 10 multicast groups.

7 WBA transport in Belgacom Ethernet network

26. Users of a Customer are only allowed in a specific LEX, if the Customer has an active “P3” (not p3bis”) shared VLAN to this LEX, otherwise no VLAN 40 VLANs, neither TV, can be configured in this LEX for his Users.
27. The WBA p3 “shared Vlan” is configured as defined in the WBA VDSL2 Offer.
28. The dimensioning of the “p3” VLAN is under responsibility of the Customer. Note that this “p3” shared VLAN may also transport BROBA over Ethernet traffic designated to his rt-VBR BROBA over Ethernet customers. It is not supporting multicast.
29. All multicast, Belgacom Shared TV Channels and the Customer’s dedicated multicast streams, is transported together with in the Belgacom “PIM Core” network, offering national coverage, towards all Service Pops on the aggregation rings.
30. IGMP from a specific VLAN (31 on figure) at ISAM NT is requesting the multicast (Belgacom Shared TV Channels Customer’s dedicated multicast streams) in the aggregation rings up to the Service pop.
31. The figure shows the multicast of a specific Multicast Group, ingested by a Customer.

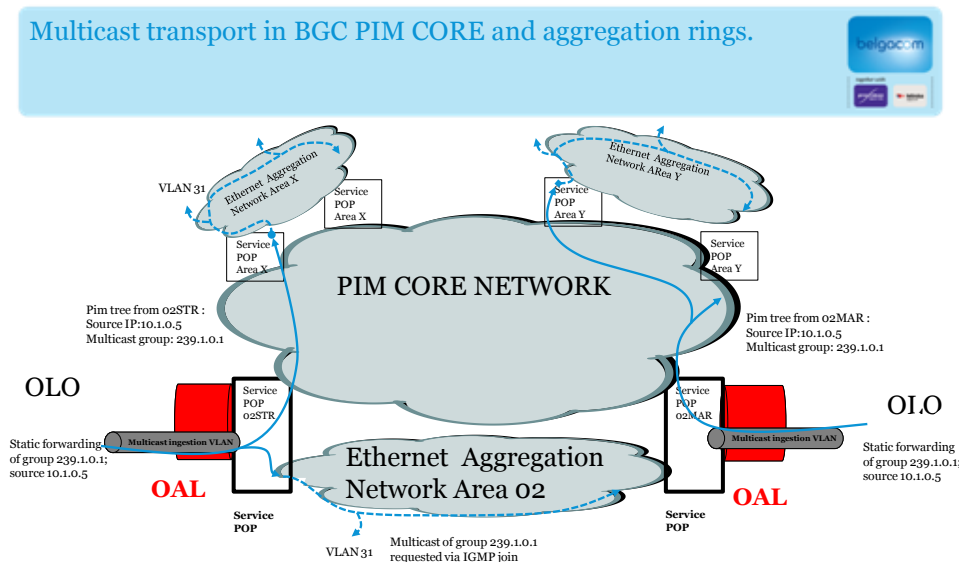

7.1 Multicast ingestion by the Customer

32. The Customer may (as an option) ingest a limited amount of multicast in the Belgacom network, which will be transported and delivered via WBA VDSL2 access, together with Belgacom TV to his TV enabled User.
33. Ingestion Bandwidth will be limited to the Ordered Dedicated Capacity for all multicast ingested by the Customer.
34. The Customer can ingest multicast groups contained in the /27 multicast address allocated to him by Belgacom. Other traffic and Unicast flows will be blocked at ingress of ingestion point in the Belgacom network. For sake of stability of the Belgacom PIM core network, no PIM protocol is allowed on Ingestion point, just static ingestion is allowed.\$
35. The Customer shall provide the following information for the configuration at DSLAM level of its dedicated multicast streams:
 - Multicast group
 - Name multicast channel
 - Ethernet BW
36. The Customer shall use one owned public unicast IP address /x (x to be decided by the Customer) as source for his multicast. Belgacom will route this in his network for both ingestion points.
37. VLAN 106 on an OAL in LEX 02STR and / or 02MAR shall be used for ingestion. The Customer can decide to use these OALs (other VLAN ids) for other regulated services, under his responsibility. The Ethernet Qos of all multicast is p4. Two injection points are meant for redundancy and shall transport exactly the same flows, because some Customer's Users will get multicast originating from a PIM tree at one ingestion point and other Customer's Users from another ingestion point, which is decided by PIM routing. A link protocol will indicate to the routing in the Belgacom network if the ingestion point is alive or not. If link protocol at one ingestion point fails, then it will release all its PIM trees and these will be rebuild from the PIM tree on the other ingestion point, if this is still up.

7.2 Shared TV Channel interface

38. The Customer can (as an option) receive the encrypted shared TV Channels which he is entitled to deliver to his Users:
 - VLAN 107 on an OAL in LEX 02STR and / or 02MAR shall be used for this flow. The Customer can decide to use these OALs (other VLAN ids) for other regulated services, eg the multicast ingestion , under his responsibility. The Ethernet Qos of all multicast is p4.
 - The data flow is obtained by a static IGMP configuration of the multicast groups, to which the Customer is entitled, at Belgacom side. No protocol is allowed (eg no IGMP). All ingress traffic in Belgacom network will be blocked.

8 MULTICAST CHANNELS

39. As part of this Wholesale offer, Belgacom provides Shared TV Channels.

8.1 MPEG 2 Transport Stream

40. Each channel is conveyed in a separate MPEG-2 transport stream which can contain video, audio and teletext.

41. Normative references:

- MPEG 2 Transport Stream: ISO/IEC standard 13818-1
- MPEG 2 measurement guidelines: ETSI EN 101290
- Teletext: Teletext based on ETSI EN300294,
ETSI EN 300472 & ETSI EN 300706 for Enhanced Teletext
- WSS carriage : ETSI EN 301775
- Mapping of audio & video in MPEG2 system: ETSI EN 101154
- Mapping of AC-3 : ETSI EN 300468

42. The following table shows the codecs used for video and audio, at the time of writing:

| | |
|----------------|---|
| Radio channels | Audio: Musicam (MP1L2) stereo |
| SD TV | Video: H.264 MP@L3 Audio: Musicam (MP1L2) stereo |
| HD TV | Video: H.264 HP@L4 Audio: AAC (MP2) stereo; or Dolby Digital |
| 3D TV | Video: H.264 HP@L4 Audio: AAC (MP2) stereo |

Note: H.264 is referring to ISO/IEC 14496.10

43. Belgacom reserves the right to change codecs. The process to be followed in case of a codec change is specified in Annex 3 – Planning and Operations.
44. Bitrates at the MPEG 2 TS level are:
- Standard Definition: 2,5 Mb/s
 - High-Definition: 6,2 Mb/s
 - 3D: 8,6 Mb/s
 - Radio channel: 0,28 Mb/s
45. Belgacom reserves the right to change bitrates. The Customer will be notified of any bitrate change at least three months before the modification is brought live for Belgacom retail Users

8.2 IP encapsulation

46. The MPEG-2 transport stream is encapsulated:
- for the TV channels: in RTP/UDP/IP.
 - for the radio channels: in UDP/IP
47. Normative references:
- RTP: A Transport Protocol for Real-Time Applications (RFC 1889)
 - RTP Payload Format for MPEG1/MPEG2 Video (RFC 2250)
48. Each channel is mapped into a specific multicast IP group. The multicast addresses are taken from the administratively scoped IPv4 multicast space, as defined in RFC 2365; and more specifically from:
- The IPv4 Organization Local Scope -- 239.192.0.0/14
 - The IPv4 Local Scope -- 239.255.0.0/16

8.3 Layer 2 encapsulation

49. On the Access Line, the IP packets are encapsulated in the appropriate layer 2 protocols, as described in the WBA VDSL2 offer.

8.4 VERIMATRIX ENCRYPTION

50. The payload of the MPEG 2 transport packets is encrypted by means of the Verimatrix “Video Content Authority System (VCAS™) for IPTV” solution.
51. The provider of this solution is:

Verimatrix Inc.

6825 Flanders Drive

San Diego, CA 92121

USA

www.verimatrix.com

8.5 Verimatrix Components

52. If the Customer wishes to use the Wholesale service with multicast needs to deploy a Verimatrix “Video Content Authority System (VCAS™) for IPTV” system with a Remote Stream Manager component.

8.5.1 VCAS™ for IPTV

53. The VCAS™ for IPTV performs stream formatting and real-time encryption of multicast IP transport streams containing compressed video in an MPEG-2 Transport Stream format. The VCAS™ solution also generates and distributes the necessary encryption keys to client devices such as Set Top Boxes.
54. In the context of this offer, the Customer VCAS™ will be used to store and distribute the encryption keys for the Shared TV channels. For the Customer dedicated channels, the Customer is free to use the conditional access technology of his choice.

8.5.2 Remote Stream Manager

55. Verimatrix Remote Stream Manager (RSM) is an optional component within the Video Content Authority System (VCAS™). RSM optimizes IPTV wholesale/retail configurations by enabling seamless end-to-end encryption of broadcast channels combined with secure, locally-originated content.

56. The Verimatrix RSM will periodically fetch the decryption keys for the shared channels that the Customer is entitled to from the Belgacom VCAS servers via a virtual private network. This enables the Customer to store these keys for further distribution to his own end customers.

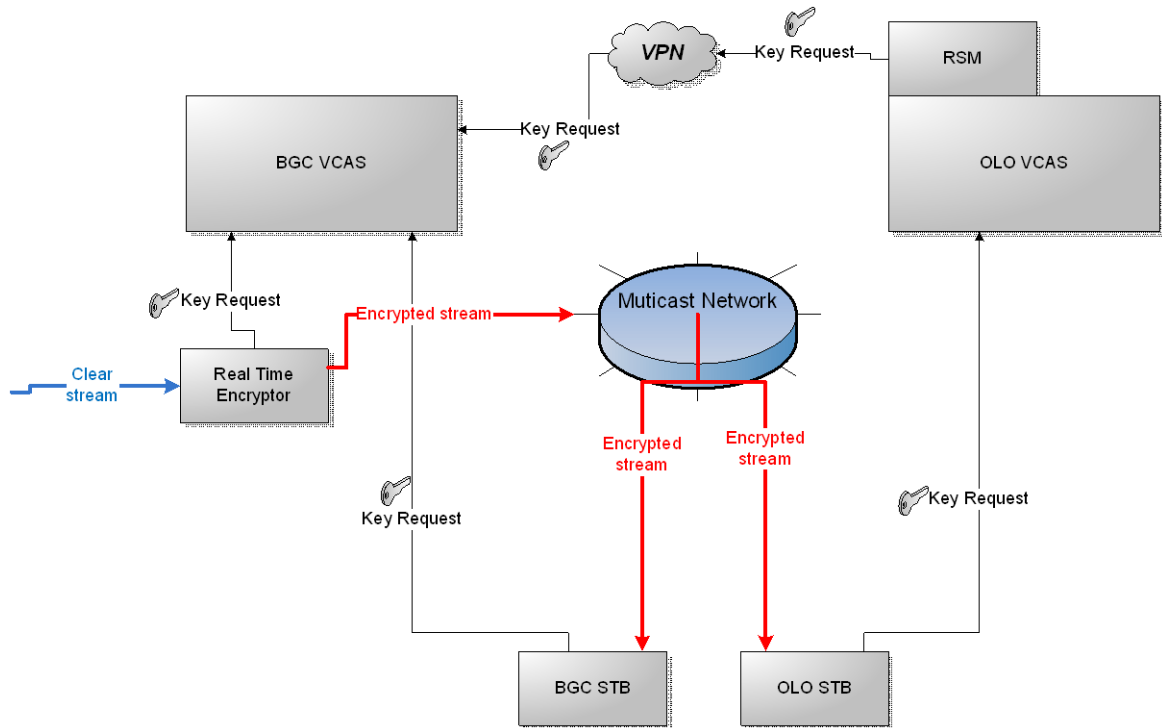

57. It is the responsibility of the Customer to securely store the encryption keys for further use.

8.6 VPN between the Customer and Belgacom Verimatrix Components

58. The virtual private network that connects the Customer RSM component to the Belgacom VCAS servers is implemented via VLANs on one or two (for redundancy) OALs. Belgacom has two redundant accesses to his VCAS™ platform, one in o2EVE (Brussels Area) and one in 15MEC (Antwerp Area).

- VLAN id 104 : to o2EVE
- VLAN id 105 : to 15MEC

◆◆◆◆◆ End of document ◆◆◆◆◆

Wholesale Multicast

Annex 3: Planning & Operations

Created on: 06 March 2012

belgacom

together with





together
with



1 Table of contents

| | | |
|----------|---|-----------|
| 1 | Table of contents | 2 |
| 2 | Introduction | 5 |
| 3 | Acronyms | 6 |
| 4 | Exchange of information | 7 |
| 4.1 | Single Point Of contact | 7 |
| 4.2 | Preliminary Exchange of Information for the initial setting up..... | 7 |
| 4.3 | Implementation Committee | 7 |
| 5 | Ordering Encryption Key Interface | 8 |
| 5.1 | General..... | 8 |
| 5.2 | Ordering procedure..... | 8 |
| 6 | Ordering Shared TV Channel | 10 |
| 6.1 | Shared TV Channel Activation..... | 10 |
| 6.1.1 | General..... | 10 |
| 6.1.2 | Prerequisites | 10 |
| 6.1.3 | Ordering procedure | 11 |
| 6.2 | Shared TV Channel Deactivation..... | 11 |
| 6.2.1 | General..... | 11 |
| 6.2.2 | Prerequisites | 12 |
| 6.2.3 | Ordering procedure | 12 |
| 6.3 | Shared TV Channel Management | 12 |
| 6.3.1 | Shared TV Channel Stop – Specific Case..... | 12 |
| 6.3.2 | Share Channel Stop – General Case | 12 |
| 7 | Ordering Dedicated Capacity | 14 |
| 7.1 | Dedicated Capacity Initial Set-up | 14 |
| 7.2 | Ordering procedure of Dedicated Capacity Initial Set-up | 15 |



together
with



| | | |
|-----------|---|-----------|
| 7.3 | Dedicated Capacity Increase | 15 |
| 7.4 | Dedicated Capacity Decrease..... | 16 |
| 7.5 | Modification of Dedicated Stream Bandwidth configuration | 16 |
| 8 | Implementation Information | 18 |
| 9 | Ordering Multicast functionality on a specific User line (WBA VDSL2) | 19 |
| 9.1 | General..... | 19 |
| 9.2 | Ordering via XML..... | 19 |
| 9.2.1 | Generals | 19 |
| 9.2.2 | Definitions | 20 |
| 9.2.3 | Escalations..... | 21 |
| 10 | Forecasting of orders..... | 22 |
| 10.1.1 | General Principles | 22 |
| 10.1.2 | Processing of Forecasts | 22 |
| 10.1.3 | Underrun | 23 |
| 10.1.4 | Overrun..... | 23 |
| 11 | Fault Reporting and Repair | 24 |
| 11.1 | General Process..... | 24 |
| 11.2 | Points of Entry for Complaint | 24 |
| 11.3 | Fault Reporting | 24 |
| 11.4 | Customer's liabilities in connection with fault reporting..... | 25 |
| 11.5 | Belgacom's liability in connection with fault reporting | 25 |
| 11.6 | Special conditions in connection with Repair | 26 |
| 11.7 | Repair Request and Feedback | 26 |
| 11.7.1 | Multicast on an User Line | 26 |
| 11.7.2 | Shared TV Channels | 26 |
| 11.7.3 | Dedicated Capacity | 27 |
| 11.8 | Wrongful repair request | 27 |
| 12 | Phases in the provisioning of the Multicast Services..... | 28 |
| 12.1 | Friendly User Testing Phase..... | 28 |



together
with



| | |
|--|-----------|
| 12.2 Full Commercial Phase..... | 28 |
| 13 Shared Channel Change Management | 29 |
| 13.1 General..... | 29 |
| 14 Glossary | 31 |
| Appendix A: Statement of requirements, template for the Customer | 32 |
| General .32 | |
| Basic information | 32 |
| Registered name and address of Customer | 32 |
| Confidentiality agreement | 32 |
| Key Contacts list | 33 |
| Key project dates | 33 |
| Wholesale Multicast Products and Services Customer wishes to obtain from Belgacom | 33 |

2 Introduction

1. This annex describes the Planning and Operations principles, related to the provisioning and repair of the Wholesale Multicast Services.
2. Both parties will use at any time their best efforts to ensure an adequate level of service provisioning both between the Parties and towards the Users concerned.
3. In the event that difficulties or problems arise in respect of Planning and Operations, the Parties will perform all necessary co-operation and consultation with a view to developing appropriate and workable solutions.
4. All relevant technical documentation and order forms if any can be retrieved at the secured part of the website for this offer.

3 Acronyms

| | |
|-------------------------|---|
| ACK | Acknowledged |
| CID | Circuit Identifier |
| CSD | Customer Support Desk |
| CWS | Carrier and Wholesale Services |
| FUT | Friendly User Testing |
| NACK | Not Acknowledged |
| REM | Retailer Entitlement Manager |
| RSM | Remote Stream Manager |
| SOR | Statement Of Requirements |
| SPOC | Single Point Of Contact |
| VDSL₂ | Very High Speed Digital Subscriber Line 2 |
| VLAN | Virtual Local Area Network. |
| VCAS | Verimatrix Content Authority Manager |

4 Exchange of information

5. This chapter includes some communication guidelines in order to ensure a good interchange of information and to define an effective communication channel that focuses on both improving the comprehension and execution of the processes.

4.1 Single Point Of contact

6. Both Parties will appoint a member of its staff as Single Point Of Contact for Wholesale Multicast. This person, referred to as "SPOC", will be in charge of all matters regarding the day-to-day management of the performance of this offer. In particular, all firm orders must be submitted by registered mail to the SPOC of Belgacom, unless noticed otherwise.

4.2 Preliminary Exchange of Information for the initial setting up

7. Without prejudice to what is stated above, it is recommended that the Customer provides a Statement Of Requirements (SOR) to Belgacom as early as possible in any discussions between The Customer and Belgacom. The SOR is sent by registered mail to the SPOC of Belgacom. After the receipt of the SOR, Belgacom shall notify to the Customer its observations, if any, concerning the SOR. In particular, when appropriate, Belgacom may request additional information to complete the information contained in the SOR. For more information on the SOR, reference is made to Appendix A of this document.

4.3 Implementation Committee

8. The Implementation Committee is a meeting between both parties to supervise, discuss and examine at a general level technical and operational application of this offer, in particular, the implementation of the respective obligations of the Parties, as described in this offer.
9. The Implementation Committee will meet at least on a quarterly basis. Each Party will be entitled to call additional meetings within reasonable notice, as may be necessary. Each Party will be represented at the Implementation Committee by its SPOC accompanied by any staff as deemed necessary by the relevant Party.
10. In addition to the Implementation Committee, the Parties will be allowed to request for the set-up of any other bilateral working group in charge of discussing and agreeing on any technical or operational issues, including more specialized members on the specific topic.

5 Ordering Encryption Key Interface

5.1 General

11. Before the Customer can order the Encryption key interface an OLO Access Line needs to be in Service in one of the following Service PoP's:
 - o2STR
 - o2MAR
 - o3CEN
 - o3BKC
12. The Encryption key interface set-up is mandatory prior to the ordering of a Shared TV channel.
13. The ordering of the Encryption Key Interface shall be done through the use of a specific template provided in Appendix D of this document. In case data is missing or is not correct, the template will be rejected. In the latter case, Belgacom will indicate the reasons of rejection on the template. All firm orders will be submitted by email to the SPOC of Belgacom for Wholesale Multicast.
14. Before a Customer can order a Shared TV channel an Encryption Key Interface is required.
15. The Encryption Key Interface is made up of:
 - A specific VLAN configured on an OAL. The OAL on which the VLAN is configured is left at Customer discretion but must end up on one of the following Service PoP: o2MAR, o2STR, o2CEN or o3BKC. Further information regarding those Service PoP's is available in the WBA VDSL2 offer – Main Body.
 -
 - Network configuration enabling the connection of the service PoP's selected by the Customer to the Belgacom VCAS platforms located in GAM and Mechelen.
 - The creation of the Customer instance in the Belgacom VCAS REM module.
16. The Encryption Key Interface is used for enabling the provisioning of Shared TV channel encryption keys from Belgacom to the Customer infrastructure.

5.2 Ordering procedure

17. The Customer can order its Encryption Key Interface through a firm order. A firm order consists of the requested Encryption Key Interface. Together with the firm order, the Customer includes the date when he wants the Encryption Key Interface to be ready.
18. The Customer is notified that in very exceptional situations, significant delays may be experienced :
 - In case of periods of large demands that could not be foreseen,
 - In an emergency situation (i.e., exceptional cases of *force majeure*),



19. When the installation of the Encryption Key Interface is done, Belgacom will confirm it to the Customer.
20. Once confirmed, the installation shall be subject to the validation of the Customer
21. The Encryption Key Interface phase isto be performed by the Customer. The Interface ordering will be considered as complete once the Customer has accepted the interface implementation through a firm confirmation
22. Belgacom shall provide the Customer with the necessary support during the validation phase.

6 Ordering Shared TV Channel

6.1 Shared TV Channel Activation

6.1.1 General

23. Belgacom will offer the Customer access to a pool of Shared TV channels.
24. Belgacom Shared TV Channels are encrypted by Belgacom and made available in Belgacom network.
25. The access is defined per channel and the Customer can decide which channel from the Belgacom Shared TV Channel pool it wants to activate.
26. The activation of a given Shared TV channel upon Customer request consists in making the corresponding encryption key available for the Customer.
27. Once a Shared TV channel is activated upon Customer request the Customer is responsible for fetching the encryption key as described in Annex 2 – Technical Specifications.
28. The Customer is responsible for all other actions required to make its end-user capable of decrypting an activated Shared TV Channel made available by Belgacom in Belgacom network.
29. Firm order of Shared TV Channel activation shall be done through the use of an order form available on the Belgacom secured website. In case data is missing or is not correct, the template will be rejected. In the latter case, Belgacom will indicate the reasons of rejection on the template. All firm orders will be submitted by email to the SPOC of Belgacom for Wholesale Multicast.
30. The request must be sent via email by the Customer to Belgacom single point of contact in charge of Belgacom Wholesale Multicast Services.
31. The order must be accompanied with a firm confirmation that the Customer is granted by the Channel owner to multicast the TV signal towards its Users.
32. The Customer can group in a single order the activation of several Shared TV Channels.
33. If multiple Shared TV Channels are ordered in the same request the Customer shall make sure that content rights confirmation for each channel is provided.

6.1.2 Prerequisites

34. An Encryption Key Interface has to be implemented between the Belgacom VCAS REM and the Customer VCAS RSM.
35. The Customer has been granted by the Right holders to provide its Users with the corresponding content.

6.1.3 Ordering procedure

36. The Customer can order a Shared TV Channel through a firm order. A firm order consists of the requested Shared TV Channel with its associated parameters (the channel name, the channel id, the implementation date,...).
37. The Customer shall provide Belgacom with the confirmation that the Right holder has granted the Customer that it can provide its Users with the corresponding content. That confirmation shall be done through the signature of the legal document provided which will be available on the Belgacom secured website.
38. The Customer is notified that in very exceptional situations, significant delays may be experienced:
 - In case of periods of large demands that could not be foreseen,
 - In an emergency situation (i.e., exceptional cases of “*Force Majeure*”).
39. All required information to manage the activated Shared TV Channel at Customer end (channel bandwidth, channel encoding parameters,...) is available on the Belgacom secured website.
40. When the activation of the ordered Shared TV Channel is done, Belgacom will confirm it to the Customer.
41. Once confirmed, the installation shall be subject to the validation of the Customer
42. The Shared TV Channel validation phase is to be performed by the Customer. The Interface ordering will be considered as complete once the Customer has accepted the interface implementation through a firm confirmation
43. Belgacom shall provide the Customer with the necessary support during the validation phase.
44. The Customer shall each time it wants to resell, in a wholesale offer towards another Party, a Shared TV Channel it has already subscribed to, reuse the Shared TV Channel ordering procedure as described here above.

6.2 Shared TV Channel Deactivation

6.2.1 General

45. The Customer can request the deactivation of a Shared TV Channel.
46. A Shared TV Channel deactivation consists of blocking the access for the Customer to the encryption key attached to the Shared TV Channel to be deactivated.
47. Firm order of Shared TV Channel deactivation shall be done through the use of an order form available on the Belgacom secured website. In case data is missing or is not correct, the template will be rejected. In the latter case, Belgacom will indicate the reasons of rejection on the template. All firm orders will be submitted by email to the SPOC of Belgacom for Wholesale Multicast.
48. The request must be sent via email by the Customer to Belgacom single point of contact in charge of Belgacom Wholesale Multicast Services.

49. The Customer is responsible of specifying the deactivation date. Belgacom cannot be hold responsible for having blocked the access to the key with regard to any complaint coming from the channel owner.

6.2.2 Prerequisites

50. The order is relative to an existing Shared TV Channel and must contain its correct identification.

6.2.3 Ordering procedure

51. The Customer can deactivate a Shared TV Channel through a firm order. A firm order consists of the requested Shared TV Channel with its associated parameters (the channel name, the channel id, the deactivation date,...).
52. The Customer is notified that in very exceptional situations, significant delays may be experienced:
 - In case of periods of large demands that could not be foreseen,
 - In an emergency situation (i.e. exceptional cases of *force majeure*).

6.3 Shared TV Channel Management

6.3.1 Shared TV Channel Stop – Specific Case

53. Belgacom is granted the right to block the access of the Customer to an encryption key of a previously ordered Shared TV Channel if the Right holder requires it.
54. The OLO is responsible for requesting the deactivation of a Shared TV Channel it has previously ordered. Belgacom cannot be hold responsible for allowing the Customer to fetch encryption keys of a Shared TV Channel it has previously ordered and for which it confirmed it had the appropriate content rights.

6.3.2 Share Channel Stop – General Case

55. Belgacom can decide to stop multicasting a given Shared TV channel. Such a decision can be taken unilaterally without the approval of the Customer.
56. The stop of a Shared TV Channel is non-discriminatory and is enforced for all parties using the Shared TV Channel.
57. Belgacom shall notify the customer at least 2 months prior to the stop of a given Shared TV Channel.
58. The notification shall specify the stop date and the channel name and channel id to be stopped.



59. The stop of a given Shared TV channel consists of blocking the access to the encryption key corresponding to the channel to be stopped.
60. If Belgacom decides to stop a Shared TV channel, the channel is removed from the Belgacom Shared TV Channel pool and cannot be ordered as of the Shared TV Channel stop notification date.
61. Belgacom is not obliged to fill the capacity left free by the Shared TV Channel removed from the Belgacom Share Channel pool with any other content.
62. If Belgacom decides to use the capacity left free by a Shared TV Channel previously removed and to add a new Shared TV Channel, the Customer will be notified 2 months before the Shared TV Channel will be commercially available in the Belgacom retail offer.

7 Ordering Dedicated Capacity

63. The Dedicated Capacity is managed via four types of processes:
- Dedicated Capacity initial set-up
 - Dedicated Capacity increase
 - Dedicated Capacity decrease
 - Modification of Dedicated Streams bandwidth configuration

7.1 Dedicated Capacity Initial Set-up

64. Before the Customer can order Dedicated Capacity an OLO Access Line needs to be in Service in both Bruxelles area service PoP's (o2STR and o2 MAR).
65. The Dedicated capacity is capacity that the Customer can order to inject its own multicast streams. Belgacom will reserve a range of 32 Multicast IP addresses dedicated to the multicast streams the Customer wants to inject into the Belgacom network.
66. The streams so injected by the Customer are added at PIM core level to the channels of the Shared TV Channel pool and made available to Customer Users which benefit from the multicast functionality (see§ 9).
67. The dedicated capacity is capped at the Ordered Dedicated Capacity. Through shaping any overuse of this capacity will lead to packet drop and signal quality degradation.
68. The Dedicated capacity is made up of:
- The configuration of a VLAN with a bandwidth dimensioned as per the Ordered Dedicated Capacity over OAL's terminated in o2MAR and O2STR Service PoP's.
 - Configuration for connecting o2STR and o2MAR VLAN's to Belgacom PIM core Network.
 - The configuration of all Belgacom IP-DSLAM's with the Multicast IP addresses allocated to the Customer and the bandwidth assigned to each IP address by the Customer.
 - The bandwidth corresponding to the Ordered Dedicated Capacity for Customer's multicast streams.
69. Once the Order request received and validated Belgacom will provide the Customer with the 32 Multicast IP addresses reserved for the Customer dedicated multicast streams.
70. The Customer is responsible for allocating to each Multicast IP address a given bandwidth.
71. The total bandwidth allocated to all multicast IP addresses can exceed the Ordered Dedicated Capacity and all Multicast IP addressed may not be used. The only limitation is the volume actually injected into the Belgacom network.
72. The ordering of dedicated capacity shall be done through the use of a specific template provided on the Belgacom secure website. In case data is missing or is not correct, the template will be rejected. In the latter case, Belgacom will indicate the reasons of rejection on the template. All firm orders will be submitted by email to the SPOC of Belgacom for Wholesale Multicast.
73. The Multicast IP addresses and the corresponding bandwidth shall be transmitted by the Customer to Belgacom via email. Belgacom will validate the sending through a receipt acknowledging the

reception of the email. In case of inconsistency in information provided by the Customer to Belgacom, Belgacom will reject the message and will mention the reasons of the rejection.

74. The Dedicated Capacity ordering is done through two phases: one corresponding to the Multicast initial set-up before the Customer starts its Multicast operations and one covering the period after the operational launch.
75. In the Dedicated Capacity initial set-up the Customer can order up to 25 000 Kbps or less. If the Customer orders less than 25 000 Kbps, Belgacom will make the remaining capacity free so that it could be ordered by anyone else according to a fair split between requestors.

7.2 Ordering procedure of Dedicated Capacity Initial Set-up

76. The Customer can order dedicated capacity through a firm order. A firm order consists of the requested dedicated capacity. Together with the firm order, the Customer includes the date when he wants the dedicated capacity to be ready.
77. The Customer is notified that in very exceptional situations, significant delays may be experienced :
 - In case of periods of large demands that could not be foreseen,
 - In an emergency situation (i.e., exceptional cases of *force majeure*),
78. Based upon the Multicast IP range received from Belgacom, the Customer shall allocate the bandwidth to each IP address and communicate that information to Belgacom for further configuration into Belgacom IP-DSLAM.
79. Once confirmed, the installation shall be subject to the validation of the Customer
80. The dedicated capacity validation phase is to be performed by the Customer. The ordering will be considered as complete once the Customer has accepted the dedicated capacity implementation through a firm confirmation.
81. Belgacom shall provide the Customer with the necessary support during the validation phase.

7.3 Dedicated Capacity Increase

82. Once the Customer has launched its Multicast activities and has not ordered its complete Available Dedicated Capacity it can order an increase of dedicated capacity. The sum of that capacity increase and the Ordered Dedicated Capacity cannot exceed 25 000 Kbps (Available Dedicated Capacity). Even though the sum is less or equal to the available Dedicated Capacity Belgacom cannot guarantee that the request will be granted. The request approval will depend on the remaining bandwidth in the network.
83. The Dedicated Capacity increase, if accepted, consists of an increase of the Ordered Dedicated Capacity.
84. The ordering of Dedicated Capacity increase shall be done through the use of a specific template provided on the Belgacom secured website. In case data is missing or is not correct, the template will be rejected. In the latter case, Belgacom will indicate the reasons of rejection on the template. All firm orders will be submitted by email to the SPOC of Belgacom for Wholesale Multicast.

85. Before a Dedicated Capacity increase is accepted by Belgacom the following must be fulfilled:
- A dedicated capacity must have been ordered and implemented.
 - The sum of the dedicated capacity increase and the Ordered Dedicated Capacity must be lower or equal to the Available Dedicated Capacity.
 - There is available bandwidth in the Belgacom network.
86. The Customer is notified that in very exceptional situations, significant delays may be experienced :
- In case of periods of large demands that could not be foreseen,
 - In an emergency situation (i.e., exceptional cases of *force majeure*),
87. When the configuration of Dedicated Capacity increase is done, Belgacom will confirm it to the Customer. By confirming the implementation Belgacom ensures that it has performed all the necessary checks under Belgacom reach, aiming at validating the implementation.

7.4 Dedicated Capacity Decrease

88. The Customer can decide to decrease its Ordered Dedicated Capacity.
89. Any Dedicated Capacity foregone through a Dedicated Capacity decrease order is considered as available. Belgacom will make the remaining capacity free so that it could be ordered by anyone else according to a fair split between requestors.
90. The Dedicated Capacity decrease, if accepted, consists of a decrease of the Ordered Dedicated Capacity.
91. The ordering of Dedicated Capacity decrease shall be done through the use of a specific template provided on the Belgacom secured website. In case data is missing or is not correct, the template will be rejected. In the latter case, Belgacom will indicate the reasons of rejection on the template. All firm orders will be submitted by email to the SPOC of Belgacom for Wholesale Multicast.
92. Before a Dedicated Capacity decrease is accepted by Belgacom the following must be fulfilled:
- A dedicated capacity must have been ordered and implemented.
 - The Ordered Dedicated Capacity before the order is submitted is greater than 0 (“zero”).
93. The Customer is notified that in very exceptional situations, significant delays may be experienced :
- In case of periods of large demands that could not be foreseen,
 - In an emergency situation (i.e., exceptional cases of *force majeure*),
94. When the configuration of Dedicated Capacity decrease is done, Belgacom will confirm it to the Customer. By confirming the implementation Belgacom ensures that it has performed all the necessary checks under Belgacom reach, aiming at validating the implementation.

7.5 Modification of Dedicated Stream Bandwidth configuration

95. The Customer can request a change of the dedicated stream bandwidth configuration.

96. A dedicated stream bandwidth modification consists of modifying the bandwidth allocated to each or some of the Multicast IP addresses reserved to the Customer.
97. The ordering of dedicated stream bandwidth modification shall be done through the use of a specific template provided on the Belgacom secured website. In case data is missing or is not correct, the template will be rejected. In the latter case, Belgacom will indicate the reasons of rejection on the template. All firm orders will be submitted by email to the SPOC of Belgacom for Wholesale Multicast.
98. Before a modification of Dedicated bandwidth is accepted a dedicated capacity must have been ordered and implemented.
99. The Customer can proceed with modification of dedicated stream bandwidth through a firm order. A firm order consists of the modification of the dedicated stream bandwidth.
100. The Customer is notified that in very exceptional situations, significant delays may be experienced :
 - In case of periods of large demands that could not be foreseen,
 - In an emergency situation (i.e., exceptional cases of *force majeure*),
101. When the configuration of the new Multicast IP address bandwidth is done, Belgacom will confirm it to the Customer. By confirming the implementation Belgacom ensures that it has performed all the necessary checks under Belgacom reach, aiming at validating the implementation.
102. Once confirmed, the implementation shall be subject to the validation by the Customer.
103. A dedicated stream bandwidth modification will be allowed twice a year only on a fixed date to be defined by Belgacom. Any supplementary request in the same year will be rejected by Belgacom.
104. Belgacom will communicate the date to the Customer at least three month before the implementation starts.

8 Implementation Information

105. The list of Shared TV Channels available in the Belgacom Shared TV channel pool is available on the Belgacom secured website
106. The following information is available for each channel
 - The channel name
 - The channel identifier
 - The channel bandwidth
 - The Channel Multicast IP address
 - The Channel encoding features
107. Via the tools offered in the WBA VDSL2 offer the Customer can already check the parameters of the User line.
108. Based upon that information the Customer can define and build its own IPTV offer based upon the capacity of the line.
109. Belgacom cannot be hold responsible for malfunctioning of the Customer offer which does comply with the line and the Shared TV channel parameters.

9 Ordering Multicast functionality on a specific User line (WBA VDSL2)

9.1 General

110. A commercial contract is signed between a User and the Customer.
111. The ordering of Multicast functionality on a User line is fully based on the WBA VDSL2 ordering framework as specified in WBA VDSL2 Reference Offer – Annex 4 Planning and Operations.
112. Multicast functionality on a User line can be ordered either at line ordering itself or on an existing User line.
 - Either the Customer includes explicitly the Multicast functionality into the order aiming at activating a new WBA VDSL2 User line.
 - Or Multicast is activated on an already ordered WBA VDSL2 User line through a dedicated Multicast activation request.
113. The ordering processes as specified in the WBA VDSL2 Reference Offer in Annex 4 – Planning and Operations are not modified. Orders and Messages remain the same as well as the processes in which they are involved.
114. Only the content of XML's is updated to reflect the possibility to activate Multicast functionality:
 - Concurrently with a WBA VDSL2 User line
 - On an existing WBA VDSL2 line.
115. Regardless the ordering way the Customer introduces a request to activate Multicast; Belgacom verifies that the end-user line aimed by the order is configured with the service quality P3 independently from other services quality configured on the WBA VDSL2 line.
 - If Belgacom cannot find any P3 configured on the end-user line the order will be rejected. The list of reject code related to multicast ordering is available in the XML content description.
 - If the User line is configured with service quality P3 then Belgacom will activate the multicast functionality in the IP-DSLAM relevant for the User line aimed by the order.

9.2 Ordering via XML

9.2.1 Generals

116. All exchange of information between Belgacom and the Customer will be done through an electronic system.
117. Reference is also made to the Belgacom Wholesale secured website – Regulatory information – WBA - Information on ordering, for more detailed information on the ordering process via XML.

118. The communication process between Customer and Belgacom is based on SMTP Mail for the transfer, an ACK/NACK protocol and a message file in attachment with a predefined format.
119. The messages that are exchanged between the Customer and Belgacom are encrypted and signed by the sender. Each message contains one order form in attachment that is coded in XML. Technical Info and the order forms for XML ordering are included on the secured website.
120. The Customer prepares the file in the predefined XML format, signs it, encrypts it, attaches it to a mail and sends it to the mailbox of Belgacom. The e-mail address for Wholesale Broadband Access VDSL2 is WBS@belgacom.be.

9.2.2 Definitions

121. Messages required for the management of Multicast on a User line follow the specifications defined in the Wholesale WBA VDSL2 reference Offer – Annex 4.
122. The present paragraph specifies how multicast is integrated in the WBA VDSL2 message framework. Either the XML content of the considered order is impacted or it is not but in both cases the result of the order on the Multicast functionality is described

9.2.2.1 Order Messages

INITIATED BY THE CUSTOMER

- **PROVIDE NEW**: The Customer can activate Multicast by completing a PROVIDE NEW order with a Multicast activation request. The XML content description is updated to enable the Customer to add Multicast in the WBA VDSL2 PROVIDE NEW order.
- **CEASE**: A CEASE request for a WBA VDSL2 User line on which Multicast is activated deactivates also Multicast on the User line targeted by the CEASE order. The XML content description of a CEASE order is not impacted by the Multicast functionality.
- **CONVERT – cease part and provide part**: The cease part of a CONVERT request on a WBA VDSL2 User on which Multicast is activated triggers the deactivation of Multicast. The XML content description of the cease part of a CONVERT order is not impacted by the Multicast functionality. Because Multicast is not available on other technologies than VDSL2 the provide part of a CONVERT request is not impacted. If a multicast activation request is added to the provide part, the provide part is rejected by Belgacom.
- **PROVIDE CHANGE OWNER**: A PROVIDE CHANGE OWNER request on a WBA VDSL2 line on which Multicast is activated does not activate Multicast on the new WBA VDSL2 User line. The XML content description of a PROVIDE CHANGE OWNER order is not impacted by the Multicast functionality.
-
- **CHANGE**: The CHANGE order can be used by the Customer to trigger the activation/deactivation of Multicast on an existing WBA VDSL2 User line. The XML content description is updated to enable the Customer to use a CHANGE order to activate/deactivate Multicast on an existing WBA VDSL2 User line.

INITIATED BY BELGACOM DUE TO AN ACTION OF ANOTHER CUSTOMER OR FROM THE END-USER CUSTOMER ON HIS VOICE SERVICE

- **CEASE CHANGE OWNER** : Triggers the deactivation of Multicast on the WBA User line aimed by a validated **PROVIDE CHANGE OWNER** of another Customer, or an action started by the end-user-customer of Belgacom
- **MOVE – cease part and provide part** : : The cease part of a MOVE request on a WBA VDSL2 User on which Multicast is activated triggers the deactivation of Multicast. The provide part of a MOVE request can be completed with a multicast activation request in order to activate Multicast on the new WBA VDSL2 User line.

9.2.2.2 **Answer Messages**

123. An Answer Message can be:

- **REJECT**: A new set of rejection codes are defined specifically for Multicast. These codes are available on the Belgacom secured website.

9.2.3 **Escalations**

124. An escalation can be requested in case of Belgacom Fault (e.g. implementation mistake)
125. The Customer will in a first phase call (phone) Belgacom to prioritize the order and confirm by e-mail to Car_LLU. Belgacom will verify this request, and handle it in a manual escalation mode if the request for escalation is justified.
126. An escalation order has no additional cost.

10 Forecasting of orders

10.1.1 General Principles

127. This chapter describes the forecast process. The forecasts are mandatory to guarantee to respond to orders placed during the provisioning period and this is needed to help Belgacom to plan a reasonable capacity to fulfil customer's demand.
128. Beneficiaries are guaranteed that Belgacom will set up the necessary resources for the period concerned to meet its market needs, independent of the needs of other Beneficiaries. In addition, the forecast entitles the Customer to the conditions for delays determined in the Service Level Agreement.
129. For the orders exceeding the forecasts no guarantee will be offered and they will be carried out, as soon as possible, according to the remaining capacity available. If the forecasted volumes cannot be installed, the Customer will be informed within 30 working days and parties will cooperate to find the most acceptable solution.

10.1.2 Processing of Forecasts

130. The following services, part of the whole Multicast Services, must be subject to forecasts.

| Product Ordering | Frequency | Forecast period | Forecast Availability date |
|--|-------------|---|--|
| Activation/Deactivation of Multicast on an User line | Monthly | 1 month | The 10 th , 2 month before the forecast period (10 th of Sept. for forecast of Nov.) |
| Activation/Deactivation of Shared TV Channels | Half-yearly | 6 months (January – June/July - December) | The 10 th of Nov (Jan-June) The 10 th of May (July-Dec) |
| Modification of Dedicated Stream Bandwidth | Half-yearly | 6 months (January – June/July - December) | The 10 th of Nov (Jan-June) The 10 th of May (July-Dec) |

131. Belgacom will propose an individual forecast to each Customer, based on the mathematical average of the actual ordered volumes of the Customer over the last 6 months. Belgacom will download on the dedicated e-libraries of each Customer the individual forecast proposal. This forecast will be elaborated according to the period specified in the table above and made available as indicated in the table above.

132. The Customer is responsible for the accuracy of the forecast. Therefore, the Customer is requested to confirm or modify this forecast by e-mail (to cws.forecasting@belgacom.be), at the latest one month prior to the first forecasted period in time. Forecast modifications or confirmation shall be done through the use of the templates provided by Belgacom. These templates will only be considered as valid when they are properly completed. In case data is missing or is not correct, the forecast will be rejected (within 5 working days following its reception). In the latter case, the reasons of rejection will be indicated on the template by Belgacom
133. If no confirmation or modification is received by that time, Belgacom will consider the proposed forecasted volumes as confirmed. Once confirmed, the forecasted volumes are globalized by Belgacom into one basket. Capacity reservation, and calendar dimensioning, is done accordingly to fit the needs of the entire market.
134. In the early stage while mathematical forecast computation cannot be performed by Belgacom due to a lack of sufficient data, both Parties will enter into good faith discussions about the submitted forecasts and the feasibility to implement the forecasts concerned.

10.1.3 Underrun

135. Underrun occurs when actual ordered volumes are below forecasted volumes. Any underrun mechanism applies to the entire globalized volume of orders of the entire market.
136. A reasonable underrun of the forecasted volumes can be absorbed by Belgacom and has no direct consequences for the Customer. A reasonable underrun is considered to be no more than a 20% deviation of the forecasted volume. In case of severe underrun (i.e. more than 20%) and in case this underrun was caused by a single Customer who excessively increased the volume proposed by Belgacom, Belgacom reserves the right to limit the allowed modification for the forecast of the following 3 months for that Customer to a level deemed necessary by Belgacom.
137. E.g.: The proposed volume for all Customers for month X is 1000 (=average of the actual ordered volumes of the last 6 months.). Some Customers send a modification of their forecasted volume via CWS.forecasting@belgacom.be and the forecasted volume for all Customers is confirmed at 1500. The actual volume for month X is finally lower than 1200 (1500-20%=underrun). If among the Customers that had sent a modification, the realised volumes are more than 20 % under the modified volumes, they will be identified as responsible of the underrun and won't have the possibility to modify the proposed forecasting during the following 3 months.

10.1.4 Overrun

138. Overrun occurs when actual ordered volumes are above forecasted volumes. Any overrun mechanism applies to the entire globalized volume of orders of the entire market.
139. As from the first order exceeding the globalized forecasted volume, independently of which Customer might be the cause of this overrun, all orders of all Beneficiaries for the remainder of the month will be considered 'in overrun'. For any order in 'overrun', no guarantee on Slot Availability will be offered and they will be carried out by Belgacom as soon as possible, according to the remaining capacity available

11 Fault Reporting and Repair

140. This section describes the responsibilities of Belgacom and The Customer in fault reporting and repair.

141. This document refers to repair processes which are dedicated to the Multicast offer:

- Multicast functionality on a User line
- The Shared TV channels ordered by the Customer
- The Dedicated Capacity

142. Any Fault related to the WBA VDSL2 services impacting the Multicast TV Services must follow the Fault reporting and repair process defined in the WBA VDSL2 offer.

143. Any default related to OAL services impacting the Multicast TV Services must follow the Fault reporting and repair process defined in the WBA VDSL2 offer.

11.1 General Process

144. Repairs are carried out on the Network and TV related equipments after the Customer has informed Belgacom provided the Customer has made the preliminary investigations and is confident that the problem is in Belgacom Network. The Customer is responsible for the repair of the IPTV services for which he has the control and is responsible to filter all non-Belgacom related problems. The Customer, when reporting that there is a problem, has to give precise information about the nature of the problem. Belgacom will, when appropriate, confirm the existence of the problem.

145. If Belgacom becomes aware of a problem on the network or TV related equipments, Belgacom automatically coordinates the necessary actions to resolve the problem according to the applicable arrangements.

146. The maintenance and the development of the Network and TV related equipments may require Belgacom to limit the Multicast services or to suspend it temporarily. Belgacom undertakes to limit the duration of this period to the time that is required for the execution of the work and that duration will, in no way, be longer than the period that Belgacom would require if her own services needed to be suspended. In such cases, Belgacom will inform the Customer in due time at least 48 hours in advance, and communicate the estimated suspension time and the reason of suspension.

11.2 Points of Entry for Complaint

147. In case of repair, the following mode of contact between the Customer and Belgacom is possible:

- E-tool for repair tickets

11.3 Fault Reporting

148. It is always the Customer that

- 1) Reports faults in the Wholesale Multicast TV Services.
- 2) Receives own Users' fault reports before reporting faults to Belgacom. Belgacom will not take calls directly coming from Users of the Customer.
- 3) Handles own Users' fault reports before reporting faults to Belgacom.

149. It is the Customer's responsibility to check that there is sufficient ground to assume that the fault is with Belgacom.

11.4 Customer's liabilities in connection with fault reporting

150. For fault reporting, the Customer will contact Belgacom the e-tool.

151. Before contacting Belgacom, the Customer will test the concerned faulty equipment to ensure that the fault is attributable to Belgacom. The Customer is responsible for transmitting all necessary information requested by Belgacom. In the following cases the trouble ticket creation will be rejected:

- Information is incomplete

152. The Customer will possibly communicate to Belgacom:

- Measurements from equipment on the Customer's side that can help in solving the fault (if available).

153. It is always the Customer that receives own Users' fault reports regarding the Wholesale Multicast TV services before reporting faults to Belgacom. In case Belgacom receives fault reports regarding the Wholesale Multicast TV services, Belgacom will refer the User to the Company with whom he has signed an agreement.

154. When the Customer receives a fault from one of his Users for Wholesale Multicast TV Services, the Customer performs a first diagnostic.

- In case the issue does not require a Belgacom intervention, the Customer manages the issue and contacts the User once the issue is solved and closed.
- On the opposite, if the issue requires a Belgacom intervention (typically for network or TV related equipments issues), the Customer continues the issue resolution process with Belgacom.

11.5 Belgacom's liability in connection with fault reporting

155. Belgacom starts the fault localization and performs repair activities during working hours.

156. The Customer recognizes that:

- if necessary, the Customer is required to disconnect the terminal equipment at the User site upon Belgacom's request to carry out its proper measurements;
- The Customer's repair request must relate to the type of service for which the Wholesale Multicast TV service has been ordered;
- During the repair process the Customer may submit additional information in respect of a specific repair request, cancel a repair request or change a repair request.

157. Belgacom reports the result of the repair activities to the Customer immediately upon repair.
158. Any follow-up feedback requested by the Customer, either during the repair period, after additional tests and rejection or acceptance of the repair action, or once the fault is fixed, will be taken care of through the repair team for Multicast TV Services;
159. In any case of planned maintenance and repair that can affect the Multicast TV services, Belgacom shall inform the Customer.
160. In case the Customer contacts Belgacom by phone about an ongoing repair action, Belgacom will inform the Customer of the current repair status.

11.6 Special conditions in connection with Repair

161. In fault situations where the responsibility for the fault cannot immediately be placed, and where Belgacom makes coordinated efforts with one or more Customers, settlement is made or arranged after conclusion of the Repair.

11.7 Repair Request and Feedback

11.7.1 Multicast on an User Line

162. Any Customer's Repair Request concerning an issue rooted in a WBA VDSL2 service must follow the Repair process as specified in the WBA VDSL2 Offer.

11.7.2 Shared TV Channels

163. Customer's request for Repair at Shared TV Channel level must be entered via e-tools and will be answered by the Belgacom Operations TV team.
164. No Direct calls from the Customer's User will be accepted.
165. The Customer has to provide the Channel name and the Channel ID on which it has detected an issue.
166. Any Repair request which does not include the information required here above or including incorrect or unknown information will be rejected.
167. Any Repair request related to a channel which has not been ordered by the Customer will be rejected.

11.7.3 Dedicated Capacity

168. Any Customer's request for Repair at Dedicated Capacity Level must follow the OAL Repair process as defined in the WBA VDSL2 Offer.

11.8 Wrongful repair request

169. To encourage the Customer to perform a check first on the equipment's part of its service delivery towards its User, Belgacom will bill an incentive fee to the Customer in case of a repair request for which the fault cause is not rooted at Belgacom whereas Belgacom has performed the necessary investigations to prove it.

170. There will be an indication of the trouble ticket reference and the cause of the wrongful repair.

12 Phases in the provisioning of the Multicast Services

171. The way of provisioning the Multicast TV Services to the Customer will evolve according to the following 2 successive Phases: Friendly User Testing Phase and Full Commercial Phase.

12.1 Friendly User Testing Phase

172. During the Friendly User Testing phase, later referred to as FUT, Belgacom will introduce and support the Customer to get acquainted with the processes and systems in scope of the Multicast Services.

173. Each of the Parties will have to agree on the date of successful completion of the Friendly User Testing Phase. The FUT phase should cover a period of 20 working days.

174. The FUT Phase is executed at one Service PoP, linked to at maximum two LEX's enabled for VDSL2. The number of 'friendly user' Users (to be provided by the Customer) is set at maximum 24 per Customer.

12.2 Full Commercial Phase

175. The Full Commercial Phase will entirely be based on Customer's firm orders transmitted by the Customer. The number of orders must be reasonable and progressive to avoid that the order intake services of Belgacom are overloaded by large amounts of initial orders.

13 Shared Channel Change Management

13.1 General

176. The multicast stream change management aims at describing the requirements to be followed whenever a change related to Shared channel is triggered by Belgacom
177. Changes impacting shared channels are classified into 4 categories each being assigned a specific change management notification delay.
178. Shared Channel changes are classified as follow:

| Change Type | Description |
|----------------|---|
| Change Type #1 | Changes for which Belgacom reasonably does not foresee that it will require any adaptation at Customer side but which might lead to a shared channel stream temporary interruption. Such a change is notified to the Customer 24 hours before the change is performed in live environment. |
| Change Type #2 | Changes which require adaptation at Customer side but without any modification of Shared Channel stream features (typically Multicast IP address change). Such a change will be notified three weeks before the change is performed in live environment and will require coordination with the Customer for the definition of the change time and date. |
| Change Type #3 | Minor changes which require adaptation at Customer side with an impact on the Shared Channel stream features. Such a change will be notified three months before the change is performed in live environment and will require coordination with the Customer for the definition of the change time and date. |

| | |
|----------------|--|
| Change Type #4 | Major changes which require adaptations at Customer side with an impact requiring close coordination between parties to achieve a successful change release. Such a change will be notified at least 6 months before the change is performed in live environment. An estimated go live date will be provided in the change notification but Belgacom reserves the right to push back the go live date afterwards under the conditions that the Customer is notified at least 4 weeks before the previous go live date. |
|----------------|--|

- 179. Each time that Belgacom identify a need for a change it will notify the Customer about the change type according to delay as specified in table above.
- 180. Each change notification will be accompanied with a change specification and possible impact on the shared channel stream.
- 181. Depending on the change type Belgacom will provide the Customer with the necessary information to enable the Customer to perform its own impact assessment.
- 182. Depending on the change type Belgacom will provide the Customer with a multicast stream sample embedding the change to enable the Customer to perform its own lab testing
- 183. Depending on the change Belgacom will ensure that a test multicast stream embedding the change will be available in live environment to enable the Customer to perform its own live testing.
- 184. The Customer is responsible for performing all the tests the Customer considers as required to validate the modifications having been brought to its service delivery equipment's due to the shared channel stream change.

14 Glossary

- **TV Related Equipments:** Equipments which are not considered as network equipments but which are required for the provisioning of Shared TV Channels.

Appendix A: Statement of requirements, template for the Customer

General

185. This appendix includes a non-exhaustive list of items that should be included in the Statements of Requirements (SOR). This template is only a guideline. It is the freedom of both parties to discuss the content of the SOR.

Basic information

Registered name and address of Customer

Customer name :
Address :
Postal code and city :
Country :
Telephone number :
Fax number :
VAT registration number :
Trade register (*) :

Confidentiality agreement

186. The Parties can choose to sign a confidentiality agreement as part of the SOR. The statements included in this agreement are to be determined by the parties.



together
with



Key Contacts list

Key project dates

| | Date required by Customer | Indicative dates from Belgacom |
|--|----------------------------------|---------------------------------------|
| Requested date to start Friendly User Test | | |
| Requested bringing into service date of Wholesale Multicast ordering | | |

Wholesale Multicast Products and Services Customer wishes to obtain from Belgacom

187. Please indicate what services you wish to obtain from Belgacom in scope of Multicast TV Offer.

| Name | Interest |
|--|-----------------|
| Start-up pack including multicast functionality on WBA VDSL2 User line and fifteen sharedTV channels | Yes/no |
| Multicast Dedicated capacity | Yes/no |



together
with



Wholesale Multicast

Annex 4: SLA

Created on: 06 March 2012

belgacom

together with





together
with



1 Table of contents

| | | |
|----------|---|-----------|
| 1 | Table of contents | 2 |
| 2 | Object | 4 |
| 3 | Scope | 5 |
| 4 | Prerequisites | 6 |
| 5 | Timers | 7 |
| 5.1 | Provisioning..... | 7 |
| 5.1.1 | Ordering Multicast functionality on a specific End User Line..... | 7 |
| 5.1.2 | Provisioning of Shared TV Channel | 8 |
| 5.1.3 | Modification of dedicated stream Bandwidth..... | 9 |
| 5.2 | Repair | 10 |
| 5.2.1 | Repair Timer on the End User line | 10 |
| 5.2.2 | Repair Timer on Shared TV channels | 10 |
| 5.2.3 | Repair Time on Dedicated Capacity | 11 |
| 5.2.4 | Repair Time on Encryption Key Interface | 11 |
| 6 | Shared TV channels Availability | 12 |
| 7 | Wrongful Repair Requests..... | 13 |
| 8 | Documented reports | 14 |
| 9 | Terms and Conditions for Compensations..... | 15 |
| 9.1 | General | 15 |
| 9.2 | Provisioning Compensations..... | 16 |
| 9.2.1 | Compensation for Ordering Multicast functionality on a specific End User Line | 16 |
| 9.2.2 | Shared TV Channel Set-up Timer Compensations..... | 16 |
| 9.2.3 | Provisioning of Modification of Dedicated Stream Bandwidth Timer Escalations..... | 16 |
| 9.3 | Repair Timer Compensation..... | 16 |
| 9.3.1 | Repair Shared TV Channel | 17 |

10 Escalation procedure 18

2 Object

1. The present document defines the Terms and Conditions upon which Belgacom will deliver installation and maintenance of Wholesale Multicast Services. For all operational aspects, reference is made to the Annex 3 - Planning and Operations.
2. The terms and conditions of this SLA are applicable within the limits of the forecasted volumes provided by the Customer in line with the forecasting mechanism and deviations described in the Annex 3 (Planning and Operations).

3 Scope

3. The scope of this document is to set a framework for operational collaboration between Belgacom and Customer that ensures the respect of the fixed deadlines and an acceptable quality of the provided Services.
4. The intention is to minimize the risk of shortcomings and so motivate all parties to respect the thresholds set in this SLA and to provide an incentive to enhance the performance of both parties.
5. Both parties agree that the objective of this document is to optimize operational collaboration and all efforts should be taken to avoid compensations or penalty fees.
6. The working of this Service Level Agreement is subject to a learning curve, i.e. the current values included are values that are to be evaluated on a regular basis and should exclude excessive peaks in ordering, i.e. very concentrated ordering in a very short period of time, and must be analyzed when happening. This document is an evolving document that may be adapted and revised regularly.

4 Prerequisites

7. Both parties agree to respect the content of this document and to offer Services as described in this document.
8. When specific follow up or support needs to be performed, both parties are obliged to provide a SPOC with its respective name, telephone number or e-mail.
9. Timers in this document expressed in days are always working days unless specified otherwise. For a timer of x days, the action must be completed before end of working day x after reception of the order or other Customer message, unless specified otherwise. Timers expressed in months consist of 21 working days. Under the present document, a working day for order purposes is considered as being from 8h00 to 16h30 excluding Saturday, Sunday, Belgian and Belgacom. holidays. Belgacom holidays are 2 January and 26 December.
10. In case of massive orders, provisioning will be done on project-basis. In that case, planning can be negotiated between Customer and Belgacom. The Customer must upfront inform Belgacom when communicated forecasted volume is exceeded. In that case, although SLA will not apply, Belgacom will manage, as far as possible, this increase of orders according to its best suitability.
11. In order to ensure reasonable operational workload, the Customer should ensure a reasonable spread of his orders during the month. For the execution of the present Contract, the maximum daily volume intake is defined as 10% of the monthly forecasted volumes. The orders exceeding on a daily basis the maximum daily volume intake are exempted from the SLA conditions. Belgacom will execute these orders on a best effort basis.
12. Timer violations outside the working hours are not logged as such and shall not be used to claim service shortage.
13. The Service Level Agreement is not valid in case of events which falls outside the scope of responsibility of Belgacom as defined in the “General Terms of Conditions”.
14. Timers that are delayed due to Customer are not valid within this Service Level Agreement.

5 Timers

15. This paragraph includes the most relevant timers in the operational processes framework. The purpose is that these timers will be reviewed periodically based on experience.
16. The timers included below are binding and a revision of the latter is possible after BIPT approval.

5.1 Provisioning

5.1.1 Ordering Multicast functionality on a specific End User Line

17. This paragraph addresses the ordering of Multicast on an existing WBA VDSL2 End User line.
18. Multicast activated on a WBA VDSL2 line will enable the end user's decoder to call a specific Multicast Stream and to receive it accordingly. The ordering of Multicast functionality on a specific User line corresponds to the activation of the multicast functionality at IP-DSLAM level on the WBA VDSL2 line of a given User.
19. The ordering of Multicast in the same order as for a WBA line is out of the scope of this document. In this specific case the requirement defined in the WBA VDSL2 offer are applicable.
20. Adding Multicast in the activation of a WBA VDSL2 line for an individual User does not change timers committed in the WBA VDSL2 offer.

5.1.1.1 Multicast Provisioning Validation Timer

21. The Multicast provisioning validation timer starts the day following the day Belgacom has sent an ACK message (see WBA VDSL2 offer – Annex 3 Planning and Operations) as reply of the Customer order for activating Multicast functionality on User line.
22. The Multicast provisioning validation timer ends on the sending date of the Validate message sent by Belgacom.
23. The Multicast provisioning validation timer is not valid if the order sent by the Customer has been rejected and a Reject message has been sent by Belgacom.
24. Any Multicast functionality activation order for which the Multicast provisioning validation timer has been exceeded due to events falling outside the scope of responsibility of Belgacom (as specified in Annex 1 General Terms and Conditions) will not be considered as cases for which Belgacom has not met the Multicast provisioning execution timer.

| | |
|---|---|
| Multicast Provisioning Validation Timer (to be respected by Belgacom) | Percentage of orders validated within the corresponding validation timer |
|---|---|



together
with



| | |
|----------------|-----|
| 30 minutes | 50% |
| 2 working days | 95% |
| 5 working days | 99% |

5.1.1.2 Multicast Provisioning Execution Timer

25. The Multicast provisioning execution timer starts the day following the day the validate message has been sent to the Customer by Belgacom.
26. Any Multicast functionality activation order for which the Multicast provisioning execution timer has been exceeded due to events falling outside the scope of responsibility of Belgacom (as specified in Annex 1 General Terms and Conditions) will not be considered as cases for which Belgacom has not met the Multicast provisioning execution timer.
27. The Timer ends on the sending date of the done confirmation by Belgacom.

| | |
|--|----------------|
| | Timer |
| Multicast Provisioning Execution Timer (to be respected by Belgacom) | 8 Working Days |

28. Belgacom guarantees that the Multicast provisioning execution timer will be met for 95% of Multicast functionality activation orders on a monthly basis.

5.1.2 Provisioning of Shared TV Channel

29. This paragraph addresses the set-up and configuration of a Shared TV Channel for a given Customer
30. The Shared TV Channel set-up timer is related to the necessary activities required to activate the provisioning towards the Customer of the encryption key required for decrypting the requested Shared TV channel transported over the Belgacom multicast network.
31. The Shared TV Channel set-up timer starts the day following the day Belgacom has sent an ACK message as reply of the Customer order for activating a Shared TV Channel (See Annex 3 Planning and Operations).
32. Any Shared TV Channel activation order for which the Shared TV Channel set-up timer has been exceeded due to events falling outside the scope of responsibility of Belgacom (as specified in Annex 1 General

Terms and Conditions) will not be considered as cases for which Belgacom has not met the Shared TV Channel set-up timer.

33. The Timer ends on the sending date of the done confirmation by Belgacom. The timer does not include the validation phase to be performed by the Customer (see Annex 3 – Planning and Operations)

34. The set-up and configuration of a Shared TV channel timer is set at:

| | |
|--|-----------------|
| | Timer |
| Shared TV Channel Set-up Timer (to be respected by Belgacom) | 10 working days |

35. Belgacom guarantees that the Shared TV Channel Set-up timer will be met for 100% of Shared TV Channel activation orders.

5.1.3 Modification of dedicated stream Bandwidth

36. This paragraph addresses the modification of Dedicated stream bandwidth configuration which enables the Customer to modify the bandwidth allocated to the Multicast streams part of its Dedicated Capacity

37. The modification of dedicated stream bandwidth timer is related to the necessary activities required to modify the bandwidth allocated to Multicast IP addresses of Multicast streams dedicated to the Customer.

38. The modification of dedicated channel bandwidth timer starts on the fixed date notified to the Customer by Belgacom three months before and provided the Modification of Dedicated stream bandwidth order issued by the Customer has been validated and a validate message sent by Belgacom.

39. Any Modification of dedicated stream bandwidth order for which the modification of dedicated stream bandwidth timer has been exceeded due to events falling outside the scope of responsibility of Belgacom (as specified in Annex 1 General Terms and Conditions) will not be considered as cases for which Belgacom has not met the modification of dedicated stream bandwidth timer.

40. The Timer ends on the sending date of the done confirmation by Belgacom. The timer does not include the validation phase to be performed by the Customer (see Annex 3 – Planning and Operations)

41. The set-up and configuration of Shared TV channel timer is set at:

| | |
|--|-----------------|
| | Timer |
| Modification of dedicated stream bandwidth timer (to be respected by Belgacom) | 25 working days |

42. Belgacom guarantees that the modification of dedicated stream bandwidth timer will be met for 100% of Modification of dedicated stream bandwidth orders.

5.2 Repair

5.2.1 Repair Timer on the End User line

43. The repair timer of a WBA WDSL2 line on which Multicast has been activated is the same as the repair timer on a WBA VDSL2 line without Multicast.
44. The repair SLA specifications for a WBA VDSL2 line with Multicast must fulfill the specifications as defined in WBA VDSL2 offer – Annex 5 or Annex 5A depending on the SLA activated on the User line.

5.2.2 Repair Timer on Shared TV channels

45. This timer is related to incidents which are rooted neither in the WBA VDSL2 line nor the multicast functionality and targets only channels offered in the Belgacom Shared TV Channel pool and previously ordered by the Customer. Multicast streams injected by the Customer in case it ordered the Dedicated Capacity are out of the scope of this timer.
46. This timer covers issues arising from Shared TV Channel IPTV platform up to the injection point into the Belgacom network.
47. The repair time window for Shared TV Channels is done by trouble ticket handling during working days.
48. The repair services on Shared TV Channels with local/regional coverage are offered as per best effort principles
49. Belgacom ensures a repair time only on:
 - Shared TV Channels the Customer has ordered and for which it still has a valid subscription
 - Shared TV Channels which have a nation-wide coverage. Shared TV Channels with local/regional coverage are out of the scope of this repair timer.
50. The Shared TV Channel differentiation between local/regional and nation-wide coverage will be available on the Belgacom Secured Website.
51. The Repair Timer is not applicable in case of Force Majeure as specified in Annex 1 General Terms and Conditions.
52. The Repair time Timer is not applicable in case of Maintenance activities to be performed by Belgacom during maintenance windows defined between 06:00 AM and 12:00 AM working days.
53. In case of an outage on an HD Shared Channel Belgacom reserves the rights to replace it with its SD equivalent in order to reduce the Shared TV Channel User impact. This time required to perform that activity is considered as not included in the Repair time Timer. A stop clock and a start clock will be done respectively when the replacement activity starts and when it stops.

The repair timer on Shared TV Channel starts when Belgacom receives a Trouble ticket based on the issue description communicated by the Customer and ends at the moment Belgacom has notified the Customer that the trouble ticket is closed

| | Timer |
|--|---|
| Repair Timer Shared TV Channel (to be respected by Belgacom) | 4 working hours (excluding local/regional channels) |

54. On a monthly basis Belgacom ensures that 90% of trouble tickets received by Belgacom from the Customer and falling in the Shared TV Channel Repair timer category as specified here above will be resolved within 4 hours.
55. Belgacom will not be liable for any delay or failure to fulfill its obligations arising from any event beyond its reasonable control, such as for instance but without limitation: natural disasters (e.g. fire, flooding, earthquake), weather conditions (e.g. heavy rain, thunderstorms, snow, sun interference), strikes or intervention by a third party who does not act under the responsibility of that Party (e.g. looting, rioting, sabotage, unauthorised handling of Belgacom equipment's or cabling by broadcasters at broadcaster location).

5.2.3 Repair Time on Dedicated Capacity

56. The repair timer of Dedicated Capacity is the same as the repair timer specified for an OAL as described in the WBA VDSL2 offer Annex 5.

5.2.4 Repair Time on Encryption Key Interface

57. The repair timer of Encryption Key Interface is the same as the repair timer specified for an OAL as described in the WBA VDSL2 offer Annex 5.

6 Shared TV channels Availability

1. The availability of a shared TV channel is defined as the percentage of time that the channel is operational during a given time period.
2. The availability calculations of shared TV channels will be done on a monthly basis.
3. The calculation is based on reports extracted from the information collected on the probes connected at the injection point of the Belgacom network.
4. Local and regional Shared TV Channels are out of the scope of the Shared TV Channel availability calculations.
5. A Shared TV Channel will be considered as available in following cases:
 - Belgacom planned work
 - Broadcaster planned work
 - Unavailability rooted outside the scope of responsibility of Belgacom
 - Case of Force Majeure
 - A HD channel replaced by a SD channel.
6. The monthly availability score will be calculated as an average of the availability of the Shared TV Channels the Customer has ordered.
7. On a yearly basis the months showing the best and the worst monthly availability score are filtered out for the yearly score calculation.
8. The yearly availability score is calculated as the average of the monthly availability score of the remaining 10 months.
9. Belgacom commits to the following yearly availability score

| | Timer |
|--|---|
| Shared TV Channel Yearly Availability | 99,8% (excluding local and regional Shared TV Channels) |

10. If Belgacom does not meet the Shared TV Channel yearly availability, Belgacom will compensate the Customer as defined in the Terms and Conditions for Compensation chapter specified in the present document.

7 Wrongful Repair Requests

11. Belgacom will charge the Customer with the fee related to Wrongful Repair Requests (see Annex 5 – Pricing and Billing) if the fault is not attributable to Belgacom or if the fault results from the abnormal use of the line or any other Customer - or end user of the Customer - fault.

8 Documented reports

12. Belgacom will provide every two months the BIPT and each Customer with documented reports on the Services ordered by this Customer during these two months, containing all information needed to calculate the provisioning KPI's described in this document.
13. Services targeted by this provisioning report are:
 - Multicast activation on an existing WBA VDSL2 User line
 - Shared TV Channels
 - Dedicated Capacity
 - Modification of dedicated channel bandwidth
14. This information will be transmitted to the Customer individually, on a confidential basis.
15. This information will be provided under the form of a structured file (Excel or CSV format), and will include at least the following data:
 - For Multicast activation order on an existing WBA VDSL2 User line: Customer, CID, Order ID, product, date of order, Service Requested Date (SRD), Validate XML date, Done XML date.
 - For Shared TV Channel: Customer, Shared TV Channel Name, Shared TV Channel ID, Order ID, date of order, Service Requested Date, Validate message date, Done message Date.
 - For Dedicated capacity: Customer, Order ID, date of order, Service Requested Date, Validate message date, Done message Date.
 - For Modification of dedicated channel bandwidth: Customer, Order ID, date of order, Service Requested Date, Validate message date, Done message Date.

9 Terms and Conditions for Compensations

9.1 General

16. The MULTICAST offer contains SLA levels for shared channels that are the same as the timers which Belgacom applies to its own retail entity, thus ensuring mere non-discrimination. The MULTICAST offer even goes beyond non-discrimination by foreseeing compensations to the Customer in case of non respect with the timers concerned, which is not guaranteed by Belgacom to its end users or to its retail arm
17. Compensations are applicable in the cases that Belgacom has not respected its commitment within the timers stipulated by the present SLA or other exclusion as described in this document
18. Compensations will be settled through a Customer's invoice without VAT.
19. Payment by Belgacom of these compensations shall be sole redress available to the Customer in the event the guaranteed is not complied with.
20. Compensations are only applicable if the volumes per month are below the defined limits in the forecasting process as described in the Annex 3 – Planning and Operations.
21. In case of timer escalations, the consequences as described further in this paragraph shall be applicable to Belgacom taking into account the concerned item (Multicast activation on User line, Shared TV Channel, Dedicated Capacity, Modification of Dedicated stream bandwidth). Compensations are calculated per timer without cascade effect, meaning that if a timer has been exceeded, compensations will only be due once.
22. The Customer needs to provide Belgacom with the necessary information in case of a delayed repair or any shortage of Belgacom that gives cause for the compensations described in this Service Level Agreement. Belgacom will upon receipt verify this information. When this verification appears that the information of the Customer shows a shortcoming of Belgacom that gives cause for paying compensation, this payment will be done immediately and automatically.
23. The Customer will submit a detailed request for compensation to Belgacom including for every delayed repair at least date and hour notified/resolved, circuit id (only for multicast functionality activation on user line), problem and product type. The validity of each request for compensation will be examined by Belgacom and in case of rejection Belgacom will motivate its decision.

9.2 Provisioning Compensations

9.2.1 Compensation for Ordering Multicast functionality on a specific End User Line

24. Since the ordering of Multicast functionality on a specific End User line follows the WBA VDSL2 ordering process compensations are as specified in the WBA VDSL2 Reference Offer.

9.2.2 Shared TV Channel Set-up Timer Compensations

25. The Shared TV Channel timer compensation includes the provisioning of Shared TV Channel when the provisioning of a Shared TV Channel was not completed within the timer stipulated in the present SLA. Except in the event of other deadlines being agreed with the Customer, Belgacom undertakes to take all steps to set up the Shared TV Channel. If this deadline cannot be respected, Belgacom undertakes to inform the Customer of the reasons for the delay and also to communicate the new deadline for meeting his request.
26. The Customer will be entitled to the following compensations:

| | Compensation |
|---|---|
| Shared TV Channel Set-up Timer Compensation (to be respected by Belgacom) | € 10 per Shared TV Channel per working day delayed with a maximum of 120€ |

9.2.3 Provisioning of Modification of Dedicated Stream Bandwidth Timer Escalations

27. The Modification of Dedicated Stream Bandwidth timer compensation includes the provisioning of Modification of Dedicated Channel Bandwidth when the provisioning of Modification of Dedicated Channel Bandwidth was not completed within the timer as stipulated in the present SLA. Except in the event of other deadlines being agreed with the Customer, Belgacom undertakes to take all steps to set up the Modification of Dedicated stream Bandwidth. If this deadline cannot be respected, Belgacom undertakes to inform the Customer of the reasons for the delay and also to communicate the new deadline for meeting his request.
28. The Customer will be entitled to following compensation.

| | Compensation |
|---|---|
| Modification of Dedicated Stream Bandwidth Timer Compensation (to be respected by Belgacom) | € 10 per working day delayed with a maximum of 120€ |

9.3 Repair Timer Compensation

9.3.1 Repair Shared TV Channel

29. Interruptions of service which last more than the timers defined in Section “Repair Timer on Shared TV Channel”, and are the fault of Belgacom shall entitle the Customer to a reimbursement of the rental fee corresponding to the duration of the interruption.. In these cases, Belgacom shall notify the Customer of the timeframe in which his request will probably be carried out. The timeframe taken into consideration for calculating the reimbursement amount starts on the day after the day the trouble ticket has been created by the up to and including the day that the Service is restored.
30. The Customer will be entitled to a compensation that corresponds to 3% of the monthly recurring fee per Shared TV Channel.

| | Compensation |
|--|---|
| Repair Timer Compensations (to be respected by Belgacom) | 0,5 % of monthly recurring fee per working hour delayed |

10 Escalation procedure

31. By default Internal Escalations are performed automatically. The target of departments is to limit the number of external escalations by launching pro-actively internal escalations as soon as timers are exceeded.
32. Escalation is possible when a trouble ticket has been created.
33. External Escalation can be initiated by the Customer to level 1 at Belgacom after the defined timer has been passed. Further escalation can be requested to level 2 at day of first external escalation submitted +1 day. Escalation to level 3 can be requested at day of first external escalation submitted + 2 days.
34. Immediately External Escalation to Level 2 and Level 3 is accepted from persons at the same level in the Beneficiaries Organization in case the Level 1 escalation is done before and the level 1 escalation shows structural problems or unavailability. Level 2 and 3 will first check whether lower escalation steps have been taken, before proceeding.
35. The escalation matrix is available on the Belgacom Wholesale website.

Wholesale Multicast

Annex 5: Pricing and Billing

Created on: 06 March 2012

belgacom

together with





together
with



1 Table of contents

| | |
|----------------------------------|----------|
| 1 Table of contents | 2 |
|----------------------------------|----------|

| | |
|--------------------------------|----------|
| Preliminary notes | 3 |
|--------------------------------|----------|

| | |
|-----------------------|----------|
| 2 Pricing..... | 4 |
|-----------------------|----------|

| | |
|------------------------|---|
| 2.1 Start-up fee | 4 |
|------------------------|---|

| | |
|----------------------------------|---|
| 2.2 Multicast functionality..... | 4 |
|----------------------------------|---|

| | |
|--|---|
| 2.2.1 Onetime Configuration fee of Multicast on a WBA VDSL2 User line..... | 4 |
|--|---|

| | |
|---|---|
| 2.2.2 Monthly Multicast Recurring Fee per User Line | 5 |
|---|---|

| | |
|-----------------------------|---|
| 2.3 Shared TV Channels..... | 5 |
|-----------------------------|---|

| | |
|-------------------------|---|
| 2.3.1 Onetime Fees..... | 5 |
|-------------------------|---|

| | |
|---|---|
| 2.3.2 Monthly Shared TV Channel Recurring fee | 6 |
|---|---|

| | |
|--|---|
| 2.4 Shared TV Channels Interface | 7 |
|--|---|

| | |
|---|---|
| 2.4.1 Shared TV Channel Interface Set-up..... | 7 |
|---|---|

| | |
|---|---|
| 2.4.2 Shared TV Channel Interface Decommissioning | 7 |
|---|---|

| | |
|------------------------------|---|
| 2.5 Dedicated Capacity | 7 |
|------------------------------|---|

| | |
|-------------------------|---|
| 2.5.1 Onetime Fees..... | 8 |
|-------------------------|---|

| | |
|--|---|
| 2.5.2 Dedicated Capacity Decommissioning | 9 |
|--|---|

| | |
|---|---|
| 2.5.3 Monthly Ordered Dedicated Capacity Recurring fee..... | 9 |
|---|---|

| | |
|----------------------------------|---|
| 2.6 Wrongful repair request..... | 9 |
|----------------------------------|---|

| | |
|----------------------------------|---|
| 2.7 SLA documented reports | 9 |
|----------------------------------|---|

| | |
|-----------------------|-----------|
| 3 Billing..... | 10 |
|-----------------------|-----------|

| | |
|----------------------|----|
| 3.1 Preliminary..... | 10 |
|----------------------|----|

| | |
|---|----|
| 3.2 Recording and storage of billing data | 10 |
|---|----|

| | |
|---|----|
| 3.3 Confirmation of charging principles | 11 |
|---|----|

| | |
|-------------------|----|
| 3.4 Invoices..... | 12 |
|-------------------|----|

| | |
|-------------------|----|
| 3.5 Payment | 13 |
|-------------------|----|

| | |
|--------------------|----|
| 3.6 Disputes | 13 |
|--------------------|----|

Preliminary notes

1. All prices included in this Price List are expressed in Euro, VAT excluded. Structure and prices of the below Price List are subject to further adaptations.
2. Principle: all Multicast Fees as described in Annex 6, Pricing and Billing, will be invoiced to and are to be paid by the Customer whenever relevant.
3. The Customer shall at least order and activate fifteen Shared TV Channels before it could order its first Multicast activation on a WBA VDSL2 User line.

2 Pricing

2.1 Start-up fee

- The Startup fee is charged to Customer, operator, consultant or other that requires explanations by Belgacom Multicast specialist (Product Management and /or Customer Care service) on the offer content (e.g. this fee is not charged for negotiation meeting). This fee due until the Shared TV channels included in the start pack are configured and activated.

| Information on Multicast Services | Price |
|-----------------------------------|---------|
| Rate per hour per Belgacom person | €102,49 |

2.2 Multicast functionality

- The multicast functionality is the functionality activated at IP-DSLAM level to enable the User to call a Multicast Stream and to receive it accordingly.

2.2.1 Onetime Configuration fee of Multicast on a WBA VDSL2 User line

- The Customer will be invoiced the following amount each time that it activates multicast on an existing WBA VDSL2 User line.

| | Price |
|---|--------|
| Activation/Deactivation fee of Multicast on a WBA VDSL2 User line | €14,32 |

- If Multicast is activated along with a WBA VDSL2 User line, WBA VDSL2 activation fee as specified in the WBA VDSL2 Offer are applicable and should not be increased by the above mentioned fee.
- By default Multicast is deactivated along with a WBA VDSL2 User line and the WBA VDSL2 activation fee as specified in the WBA VDSL2 Offer is applicable and should not be increased by the above mentioned fee.

2.2.2 Monthly Multicast Recurring Fee per User Line

| | Price |
|---|-------|
| Monthly Multicast Recurring Fee per User Line | €0,54 |

9. Before activating Multicast on its first WBA VDSL2 User line, the Customer must at least order fifteen Shared TV Channels which will be considered as a Start Pack. A Radio Shared TV Channel is not considered as qualified for the Start Pack so that it shall be composed of SD or HD Shared TV Channels only.

2.3 Shared TV Channels

2.3.1 Onetime Fees

2.3.1.1 Encryption Key Interface Set-up

10. The Customer will be invoiced the following fee each time it requests the set up of an Encryption Key Interface on an existing OAL (redundant or not):

| | Price |
|-------------------------------------|---------|
| Encryption Key Interface Set-up Fee | €349,53 |

2.3.1.2 Encryption Key Interface Decommissioning

11. The Customer will be invoiced the following fee each time it requests the decommissioning of an Encryption Key Interface on an existing OAL (redundant or not):

| | Price |
|--|---------|
| Encryption Key Interface Decommissioning Fee | €264,95 |

2.3.1.3 Shared TV Channel Activation

12. The Customer will be invoiced the following fee each time it activates a given Shared TV Channel. The Shared TV Channel activation fee is independent from the type of channel (Radio, SD, HD).
13. The fee specified below will be invoice per Shared TV Channel activated independently whether multiple Shared TV Channels have been ordered through the same order.

| | Price |
|----------------------------------|---------|
| Shared TV Channel Activation Fee | €354,38 |

2.3.1.4 Shared TV Channel Deactivation

14. The Customer will be invoiced the following fee each time it deactivates a given Shared TV Channel. The Shared TV Channel deactivation fee is independent from the type of channel (radio, SD, HD).
15. The fee specified below will be invoice per Shared TV Channel deactivated independently from whether multiple Shared TV Channels have been deactivated through the same order.

| | Price |
|------------------------------------|---------|
| Shared TV Channel Deactivation Fee | €285,93 |

2.3.2 Monthly Shared TV Channel Recurring fee

16. Belgacom offers the Customer with three types of channels (Radio, SD and HD). Each channel type has a dedicated monthly recurring fee and is invoiced on per channel basis.

| Monthly Shared TV Channel recurring Fees | Price |
|--|----------|
| Monthly Radio Shared Channel Recurring Fee | €407,28 |
| Monthly SD Shared Channel Recurring Fee | €2225,29 |
| Monthly HD Shared Channel Recurring Fee | €3518,49 |

17. The Customer shall inform Belgacom upfront when a Customer's User intends to resell to or otherwise put the Wholesale Multicast Services at the disposal of a third party, so that the correct fees for the use of shared TV channels can be applied.
18. This requirement is applicable to any Shared TV Channel.
19. This requirement is applicable each time the Customer resells in a wholesale offer a Shared TV Channel to another party. The Customer will be invoiced the price per channel as many time as there are parties the Customer has resold the Shared TV Channel to.

2.4 Shared TV Channels Interface

2.4.1 Shared TV Channel Interface Set-up

20. The Customer will be invoiced the following fee each time it requests the set up of a Shared TV Channel Interface on an existing OAL (redundant or not):

| | Price |
|--|---------|
| Shared TV Channel Interface Set-up Fee | €773,51 |

2.4.2 Shared TV Channel Interface Decommissioning

21. The Customer will be invoiced the following fee each time it requests the decommissioning of a Shared TV Channel Interface on an existing OAL (redundant or not):

| | Price |
|---|---------|
| Shared TV Channel Interface Decommissioning Fee | €650,29 |

2.5 Dedicated Capacity



together
with



2.5.1 Onetime Fees

2.5.1.1 Initial Dedicated Capacity Set-up

22. The Customer will be invoiced the following fee at the initial set-up of Multicast when it request the set-up of the Ordered Dedicated Capacity.

| | Price |
|-------------------------------|--------------|
| Dedicated Capacity Set-up Fee | €6132,71 |

2.5.1.2 Dedicated Capacity Increase

23. After the initial set-up the Customer can request an increase of its Ordered Dedicated Capacity upon conditions specified in Anne 3 –Planning and Operations. Each time the Customer requests an increase of Dedicated Capacity it will be invoiced the following fee:

| | Price |
|---------------------------------|--------------|
| Dedicated Capacity Increase Fee | €281,19 |

2.5.1.3 Dedicated Capacity Decrease

24. After the initial set-up the Customer can request a decrease of its Ordered Dedicated Capacity upon conditions specified in Anne 3 –Planning and Operations. Each time the Customer requests a decrease of Dedicated Capacity it will be invoiced the following fee:

| | Price |
|---------------------------------|--------------|
| Dedicated Capacity Increase Fee | €281,19 |

2.5.1.4 Modification of Dedicated Streams Bandwidth Configuration

25. The Customer will be invoiced the following fee each time it requests a modification of Dedicated Streams Bandwidth Configuration:



together
with



| | Price |
|---|--------------|
| Modification of Dedicated Streams Bandwidth Fee | €6054,10 |

2.5.2 Dedicated Capacity Decommissioning

26. The Customer will be invoiced the following fee each time it requests the decommissioning of Dedicated Capacity:

| | Price |
|--|--------------|
| Dedicated Capacity Decommissioning Fee | €5821,19 |

2.5.3 Monthly Ordered Dedicated Capacity Recurring fee

27. The Customer will be invoiced on a monthly basis the following price per Kbps of Ordered Dedicated Capacity

| | Price |
|---|--------------|
| Monthly Ordered Dedicated Capacity Recurring Fee per Kbps | €0,64/Kbps |

2.6 Wrongful repair request

28. In case of wrongful repair request by a Customer, as defined in section 8. 8 (“Wrongful Repair Requests”) of Annex 4 (Planning and Operations), Belgacom will invoice this Customer a fee of 220 Euro.

29. Belgacom will provide the following information to the Customer: the ticket number, the date and hour of opening and closing of the ticket, the identification number (e.g. directory numbers) and the cause of the wrongful repair.

2.7 SLA documented reports

46 Belgacom is entitled to invoice the Customer for the production of the SLA documented reports described in the Annex 5, Basic SLA, section 7 “Documented reports”. The unit price per report amounts 25,14 €.

3 Billing

3.1 Preliminary

- 47 Parties are defined in the present document as Belgacom a telecommunication operator in Belgium and Customer, an undertaking authorized to practice the activities covered by this agreement under the Belgian regulatory framework.
- 48 The Belgacom billing process is based on a number of steps in which the two Parties have specific responsibilities. In order to implement this process, both Parties need to put in place (a) system(s) that will be used for the purposes of accounting and billing.
- 49 For each Multicast product, Belgacom will invoice Customer accordingly
- 50 Belgacom shall record, store and process the Billing Data in accordance with Section 2 of this Document.
- 51 The “Billing Data” is the data that is necessary to ascertain the charges payable by Customer under the Agreement. The Billing Data is recorded via the Billing System as described in Section 2.2 of this Document.
- 52 All information related to the Billing procedures between Belgacom and Customer is covered by the obligation of confidentiality set out in the Agreement. Specifically, such information will be kept strictly confidential by the Parties and will only be used for the purposes of accounting, and invoicing between the Parties and will only be disclosed between the Parties, or as legally required or in the framework of formal dispute procedures. Belgacom will be under no obligation to provide to Customer direct access to its Billing system nor to any other system or facility generating the Billing Data.
- 53 Belgacom reserves the right to modify the layout and the presentation of the invoice to the Customer.

3.2 Recording and storage of billing data

- 54 For each service chargeable under the Agreement, Belgacom shall record via its Billing System at least the following Billing Data:
 - Product/service ID;
 - Type of request;
 - Subscription date;
 - End of month of Subscription date;
 - Customer ID;
 - Account ID;
- 55 The general list of billing data indicated above is not exhaustive. Pricing is set in the Section 1 of this Annex.
- 56 Billing Data shall be stored for 60 days after the due date of the related invoice. In case of a dispute on the Billing Data, Belgacom will use all reasonable effort to keep the storage of the concerned Billing Data. The storage of these detailed Billing Data shall be limited to the disputed amount of Billing Data.

3.3 Confirmation of charging principles

- 57 All charges payable under this Agreement shall be calculated in accordance with the rules set out in the relevant provisions of this Agreement and its Annexes.
- 58 For internal purpose, Belgacom will use 6 decimals in Euro. The use of decimals is set as follows:
- Per line items up to 4 decimals can be used in Euro.
 - The revenues, VAT and the totals use decimals in Euro.
- 59 In case of electronic billing only two decimals in Euro will be used.
- 60 All the non-recurring charges will be mentioned in the Invoice of the Billing Period covering the Bringing Into Service Date.
- 61 The recurring charges for the product fees will be mentioned in the Invoice of the Billing Period which the Bringing In Service Date encompasses. The Charges will be calculated on the proportion of the Billing Period in which the product and service fee were operational
- 62 Customer amount of charges will be divided in the groups of one-time fees and recurring fees for the services described in the pricelist of this offer (Section 1 of this Annex)



together
with



3.4 Invoices

- 63 Multicast Services/Products defined on a per user basis will be invoiced as per the WBA VDSL2 billing principles further specified in the WBA VDSL2 Offer – Anne 6. The Multicast Services/products considered as per user basis and defined in previous section are listed below:
- Activation/Deactivation fee of Multicast on a WBA VDSL2 User line
 - Monthly Multicast Recurring Fee per User Line
- 64 All other Multicast Services/Products as defined in the list below will be invoiced according to the specifications described in this chapter. The Multicast services addressed by the following specifications are listed below:
- Encryption Key Interface Set-up Fee
 - Shared TV Channel Activation Fee
 - Monthly Radio Shared Channel Recurring Fee
 - Monthly SD Shared Channel Recurring Fee
 - Monthly HD Shared Channel Recurring Fee
 - Shared TV Channel Interface Set-up Fee
 - Dedicated Capacity Set-up Fee
 - Modification of Dedicated Streams Bandwidth Fee
 - Monthly Dedicated Capacity Recurring Fee
- 65 For each Billing Period, Belgacom shall provide to Customer the Invoice described hereafter. The Invoice will be established in accordance with the following rules:
- Invoice Details: the Invoice will list all the services that are provided by Belgacom to the Customer.
 - The above-mentioned Invoice will be transmitted either via ordinary mail, either via email or via CertiOne to the representatives or departments of Customer as listed in the confirmation letter for which a template is available upon request.
- 66 Any invoice or credit note transmitted by Belgacom will contain the following information, in addition to any legally required mentions and information:
- relevant Billing Period;
 - total net amount in Euro;
 - due VAT amount;
 - total amount due in Euro (including VAT);
 - Due Date.
- 67 Belgacom shall use its best endeavours to issue invoices as of the start of the applicable Billing Period. Though, in respect of the development of billing systems by both Parties and the sending of invoices, Belgacom cannot ensure that the invoicing for the products and services provided will be performed within specific delays. Delays in the production of invoices can occur under these circumstances following notification by the Billing Party. Neither party may construe any late billing by the other party as a renunciation to its right to payment of the said bills.
- 68 Notwithstanding the foregoing, if an adjustment is required following a change in the referred Price List, a pending Dispute (for which the appropriate Dispute resolution mechanisms have been timely activated in accordance with this Agreement) or the outcome of commercial negotiations having a retroactive effect, the amount of such adjustment shall be established and Belgacom shall issue an invoice or a credit note as the case may be, within 30 days from the date of the relevant adjustment.
- 69 All changes to amounts invoiced in accordance with this Section 4 will be effected through credit notes or additional invoices.

3.5 Payment

- 70 All charges due by Customer to Belgacom under the Agreement shall be paid within 30 Calendar Days after issuance of the invoice (the “Due Date”).
- 71 If Customer has sent to Belgacom a Notice of Dispute related to an amount invoiced by Belgacom and if such Dispute has not been resolved by the Due Date the disputed amount may be withheld until the dispute is resolved provided that the remaining balance is payable on the Due Date.
- 72 Credit notes will be set off against any payments due of the next invoice and are refundable when there are no outstanding invoices.
- 73 If payment is not received by Belgacom on or before the Due Date, Belgacom will be entitled to an interest calculated on the basis of the legal interest rate + 2 percent points on the unpaid balance for late payment interests, administrative and recovery costs, but is only due if the dispute has been resolved in favour of Belgacom. This interest shall accrue from the Due Date until the date of payment in full of the amount to be paid. Such interest shall accrue day by day and shall not be compounded. In the event that a Dispute resolution procedure has been initiated by Belgacom as provided by the Agreement (including Section 6 of this Document), this interest shall be limited to the legal interest rate.
- 74 Value Added Tax as well as any other applicable taxes, if any, shall be added to all or any part of the charges due under this Agreement and shall be paid by the Customer responsible for making such payment.
- 75 Any payments under this Agreement will be made in Euro and will be made by bank transfer on the bank accounts mentioned in the Invoice. Payment costs are borne by the Customer. Costs of credit notes are borne by Belgacom.

3.6 Disputes

- 76 The Parties shall use their reasonable endeavours to resolve, pursuant to this Section 6 disputes related to the calculation and settlement of the charges invoiced or to be invoiced pursuant to this Document. Notwithstanding the foregoing, either Party will be allowed to trigger at any time the dispute resolution procedure provided under the main body of the Agreement provided that such Party reasonably believes that the Dispute at stake involves aspects of the Parties’ rights and obligations broader than the mere calculation and settlement of charges pursuant to this Document. The fact that a Dispute involves aspects broader than the mere calculation and settlement of charges pursuant to this Document will not release the Disputing Party from its obligation to pay any undisputed amount pursuant to Section 2.5.2.
- 77 Any Dispute under this Section 2.6 will be triggered by a Notice of Dispute sent by registered letter by the Customer to Belgacom before the Due Date. Such Notice of Dispute will indicate the disputed amounts, as well as a summary of the grounds for the Dispute and the position of the Disputing Party. Any amount invoiced under the Agreement will be deemed accepted unless a Notice of Dispute has been sent in accordance with above.
- 78 Upon receipt of the Notice of Dispute, the Parties shall exchange by ordinary mail any information necessary or useful for solving the Dispute.
- 79 Within 15 Working Days from the date of the Notice of Dispute, Belgacom will provide, by registered mail, an answer (“Notice of Reply”) to the Customer. If Belgacom does not accept some or all the arguments of the Customer, the Notice of Reply will contain a justified reply to the arguments of the Customer. If Belgacom accepts all or some arguments of the Customer, Belgacom will, together with the Notice of Reply, issue a credit note for the relevant amount.
- 80 If, within 15 Working Days from the receipt of the Notice of Reply, the Customer confirms its position in writing by registered letter, the Parties will escalate the Dispute within their respective organization as provided under Section 2.6.6. If the Customer fails to confirm its position within 15 Working Days, from the date of the Notice

of Reply, any outstanding amounts will be paid promptly and without delay and the Dispute will be deemed settled.

- 81 If the Parties have been unable to settle the Dispute as provided under the foregoing provisions, they will refer the matter to Implementation Committee, which, if deemed necessary by either Party, will be organized for this specific purpose. If after such meeting, the Dispute remains, the Parties will follow such additional steps in the escalation procedure as provided in the main body of the Agreement, or, if requested by either Party, the Dispute will be submitted to a certified accountant to be either jointly appointed by the Parties, or, failing agreement between the Parties in this respect, to be appointed by “Belgisch Instituut voor Bedrijfsrevisoren”/”Institut Belge des Réviseurs d’Enterprise”. This certified accountant will investigate and determine a solution for the Dispute, acting as an expert and not as an arbitrator. Unless there is evidence of a manifest error, decision of the certified accountant will be final in respect of those elements covered by the Dispute referred to him/her and will be binding on the Parties. The Parties will co-operate with this investigation. The costs of the certified accountant will be borne as determined by him/her in proportion to the outcome of the Dispute. Prior to undertaking his/her mission, the certified accountant will provide the Parties with an estimate of the relevant fees and costs. Upon final settlement of the Dispute, any necessary credit note will be issued and any outstanding amount will be paid promptly and without delay.

Wholesale Multicast

Annex 6: Prepayment Terms & Conditions

Created on: 06 March 2012

belgacom



Prepayment Terms and Conditions

1. Belgacom will send on a monthly basis a pre-invoice at the latest on the 2nd working day after the starting of the month preceeding the considered billing month. For Customers that are in service, the first pre-invoice shall be based on the average of the invoices for Services issued by Belgacom during the last three months. For Customers not yet in service and concluding a new Contract, the first pre-invoice shall be based on the valuation of the average of the invoices for Services to be issued by Belgacom within the first three months of services.
2. The amount of the pre-invoice shall be adapted on a quarterly basis, i.e. increased or lowered as the case may be, based on the amounts due by the Customer for the Services provided under the Contract during the previous quarter.
3. The Customer agrees to pay the amount of the pre-invoice at the latest the 10th calendar day from the date of the pre-invoice.
4. The amount of the pre-invoice shall be paid on a specific account number to be communicated. The interests generated by the amount of the pre-invoice paid on this account during the period starting from the date the pre-invoice is paid until the date the final invoice is paid shall be accrued to the Customer.
5. Within 15 calendar days after sending the final invoice, Belgacom will send a credit note regarding the pre-invoice.
6. If for the same month the amount of the pre-invoice is higher than the amount of the final invoices, Belgacom shall reimburse the balance.
7. If for the same month the amount of the pre-invoice is lower than the amount of the final invoices, the Customer will pay the surplus.
8. Within 15 days following the final invoice, the Customer will make the payment by wire transfer. If payment is not received by Belgacom on or before this due date, Belgacom will be entitled to an interest calculated on the basis of the legal interest rate + 2 percent points on the unpaid balance for late payment interest, administrative and recovery costs. For disputed amounts, this interest is only due if the dispute has been resolved in favour of Belgacom.
9. If the Customer disagrees with an invoice received from Belgacom, it must notify in writing Belgacom thereof before the due date of such invoice in accordance with the relevant provisions of the Contract.
10. Without prejudice to other legal or contractual remedies and notwithstanding anything to the contrary in the Agreement, in the event the Customer fails to pay in due time any undisputed amount due under the present Prepayment terms and conditions, Belgacom shall be entitled to:
 - Suspension of any SLA obligation;
 - Refusal in writing of any new Order;
 - Suspension of the existing Services in accordance with article 82 of the Annex 1 – General Terms and Conditions.